

Laneri[®]

sanitary ware

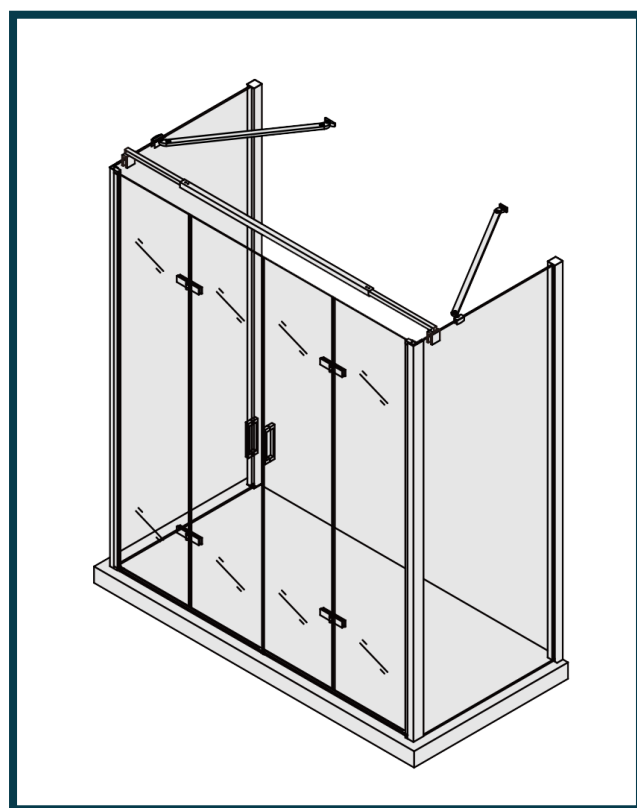
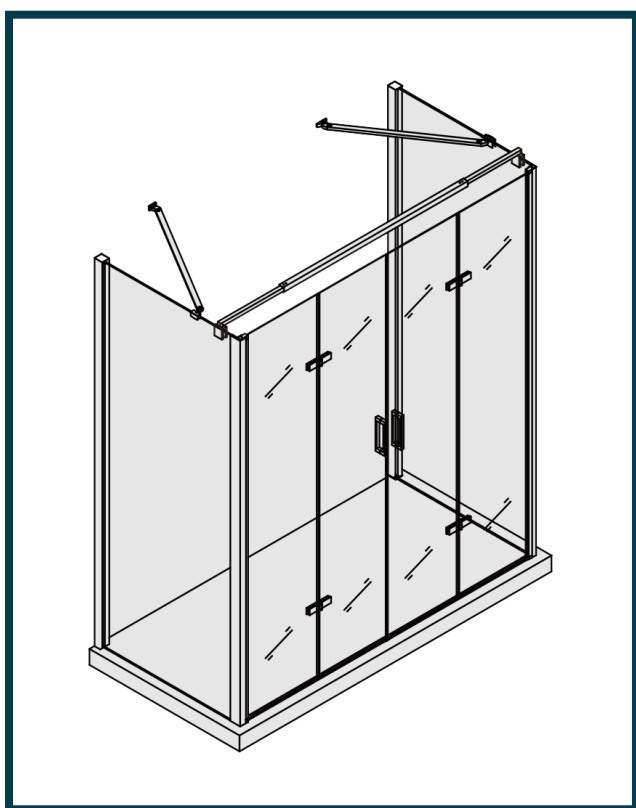

 YouTube LANERI SRL

Buenos Aires 3.0



ITALIANO PAG. 3



FRANÇAIS PAG. 13



DEUTSCH PAG. 23

Laneri®

sanitary ware

c/da Gentilomo snc
94100 Enna Italy
www.laneribagni.it

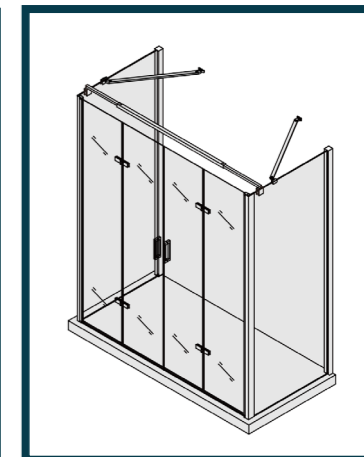
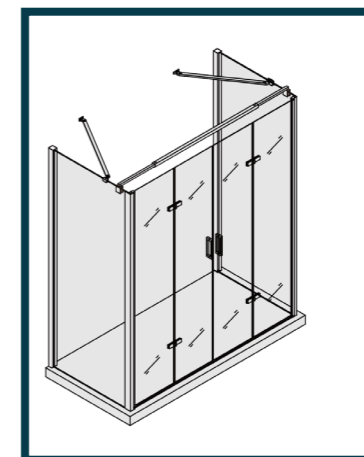

Buenos Aires 3.0

DESCRIZIONE

Box doccia a tre lati con doppia Porta Libro a 4 ante con apertura totale a ingresso libero abbinata a due pareti fisse laterali. Altezza 190 cm.
Vetro 6 mm temperato con trattamento easy-clean anticalcare .

ELABORATO TECNICO

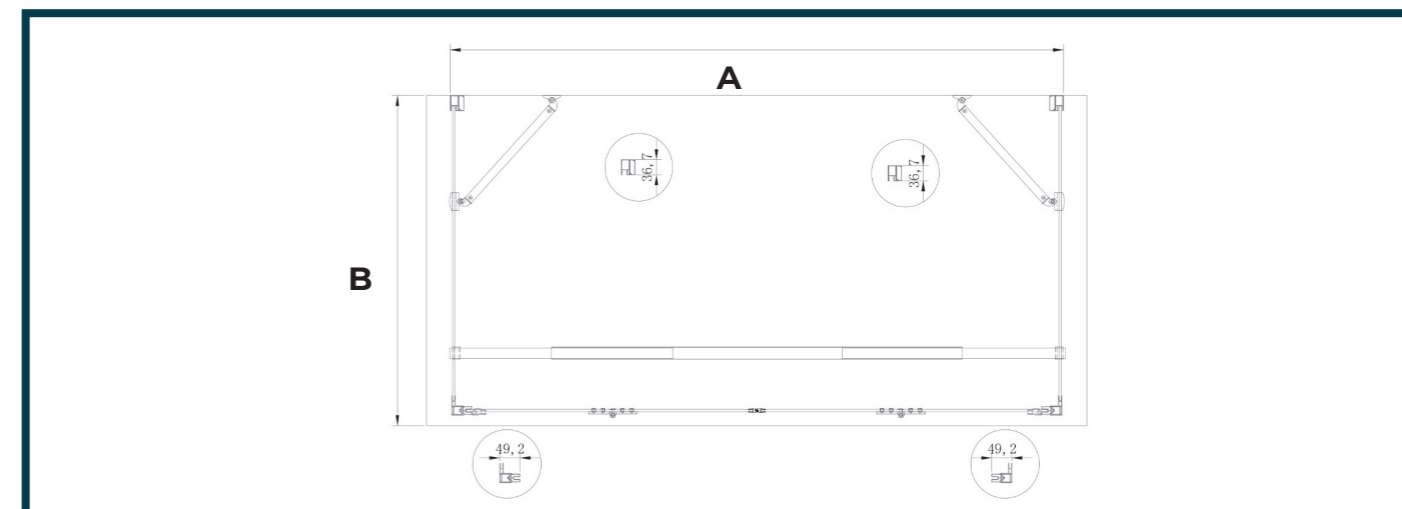

DETTAGLIO PROFILI

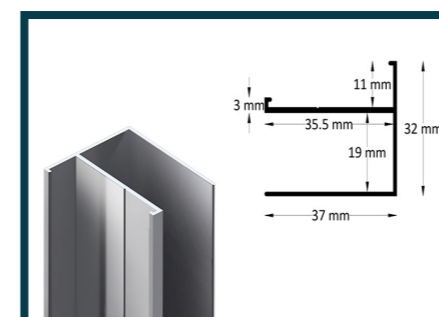

Profilo a muro parete fissa

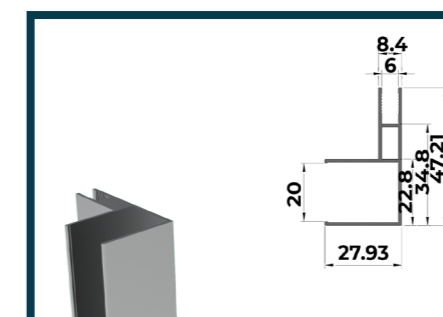

Profilo ad angolo

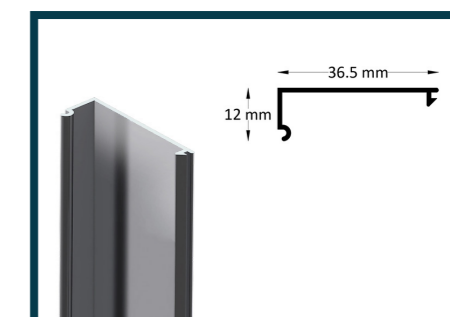

Cover profilo a muro parete fissa

Buenos Aires 3.0



TABELLA REGOLAGGIO LATO A

MODELLO	REGOLAGGIO A	
	MIN.	MAX.
110	1085	1120
120	1185	1220
130	1285	1320
140	1385	1420
150	1485	1520
160	1585	1620
170	1685	1720
180	1785	1820
190	1885	1920

TABELLA REGOLAGGIO LATO B

MODELLO	REGOLAGGIO B	
	MIN.	MAX.
65	625	650
67,5	650	675
70	675	700
75	725	750
80	775	800

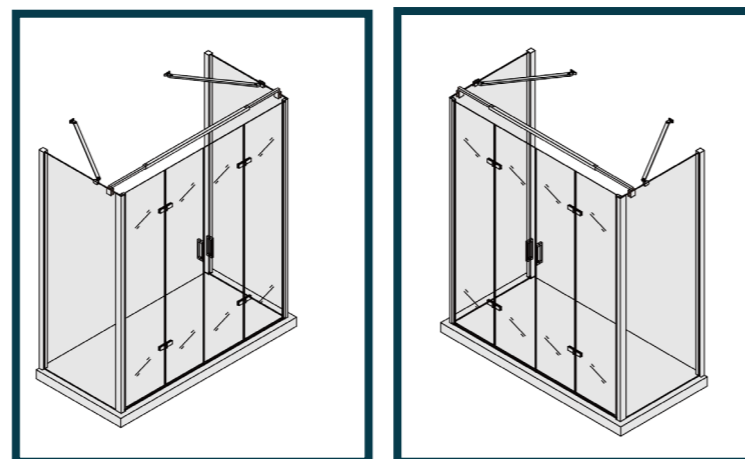
Buenos Aires 3.0

UTENSILI NECESSARI



Matita

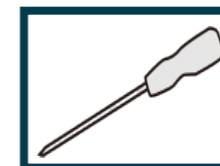

Cacciavite

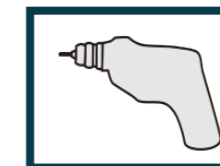

Trapano

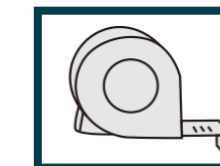

Metro a nastro

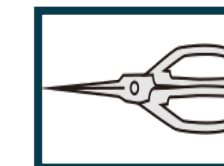

Forbice

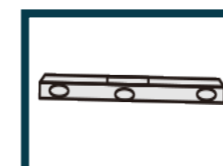

Livello



Chiave esagonale

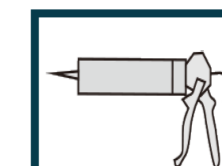

Silicone

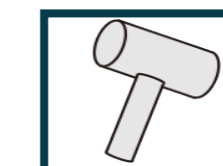

Martello di gomma

CONTENUTO DELLA CONFEZIONE

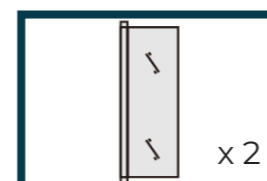

Vetro 6 mm lato porta x 2

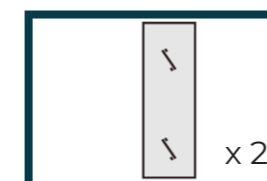

Vetro 6 mm lato chiusura porta x 2



Barra di tenuta obliqua x 2

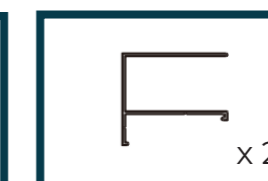

Profilo a muro fissa x 2

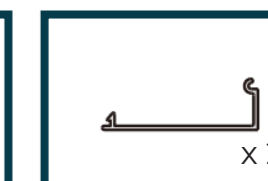

Cover profilo a muro fissa x 2

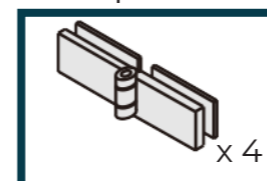

Cerniera x 4

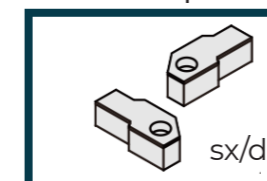

Supporti di fissaggio sx/dx

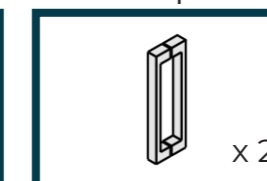

Maniglia x 2



Barra di tenuta acqua inferiore x 1



Guarnizione aletta paraschizzi x 2



Guarnizione cala-mita x 2



Guarnizione salvagoccia x 4

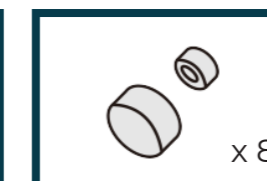

Guarnizioni e tappi per viti x 8



Tassello x 12



Vite 4 x 30 x 10

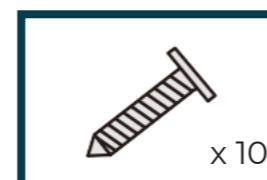

Vite 4 x 16 x 10

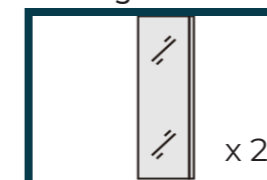

Parete fissa x 2

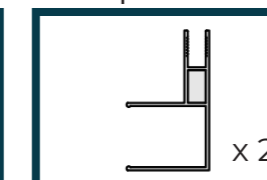

Profilo ad angolo x 2

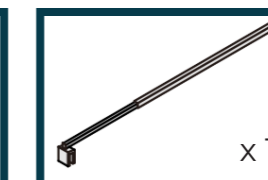

Barra di tenuta orizzontale x 1

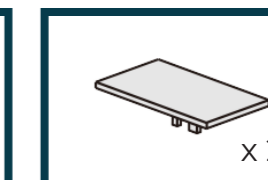

Cover superiore profilo vetro fisso x 2

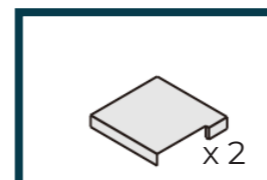

Cover superiore profilo a muro x 2

MONTAGGIO

1° PASSAGGIO

1. Verificare la messa in bolla del piatto doccia con il livello.
2. Poggiare i profili a muro ed utilizzare il livello per la messa a piombo.
3. Tracciare i fori a muro con la matita.
4. Praticare i fori a muro con il trapano.
5. Inserire il tassello a muro e avvitare le viti per fissare i profili.

IMPORTANTE

è buona norma **non montare** i profili a ridosso del bordo esterno del piatto doccia, **lasciare sempre circa 1 cm per un risultato estetico e tecnico ottimale**

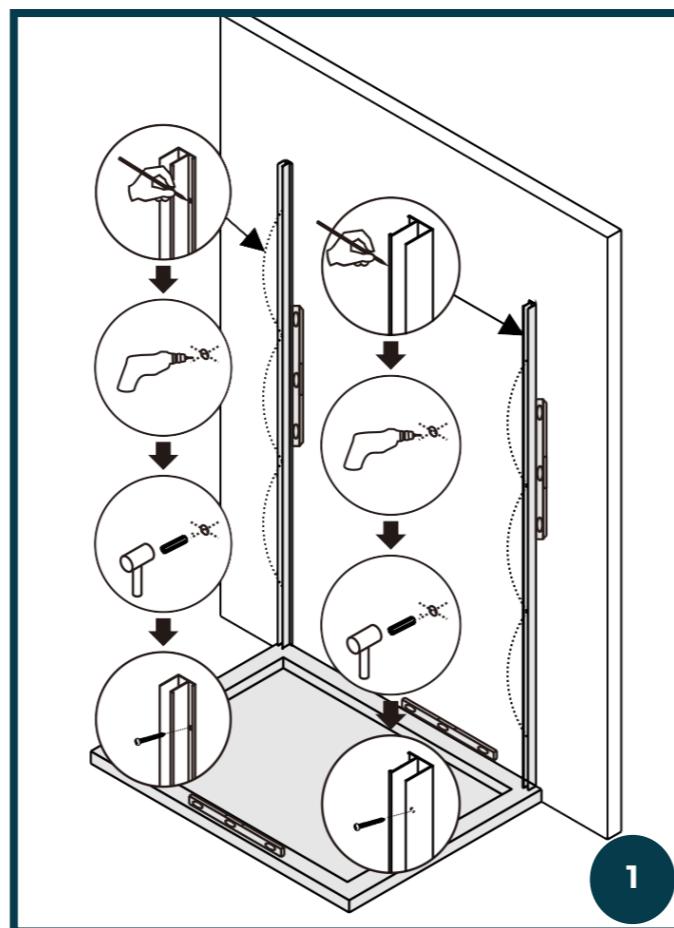

2° PASSAGGIO

1. Silconare i Profili ad angolo sulle pareti fisse ed attendere che il silicone faccia presa tra vetro ed alluminio.
2. Posizionare le pareti fisse nei Profili a muro

Suggerimento

Togliere il profilo muro dalla parete, inserirlo nella parete fissa e risposizionare il tutto a muro, l'operazione risulterà più facile.

Nota bene:

le lastre fisse non hanno telaio e/o guarnizione sotto, vanno poggiate e silconate al piatto doccia preferibilmente dall'esterno.

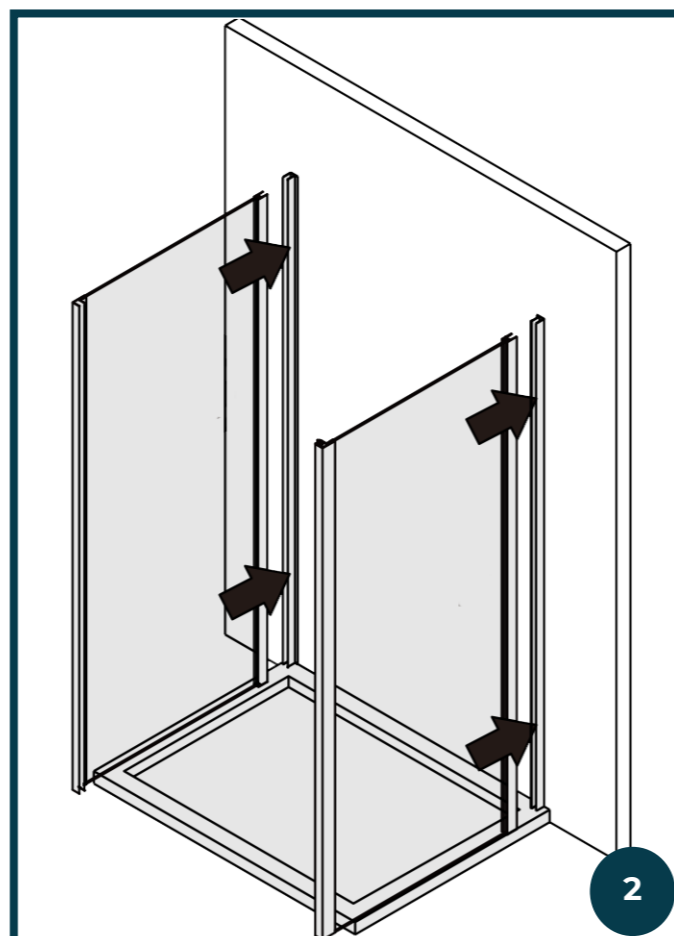

3° PASSAGGIO

1. Posizionare tra i due vetri la barra di tenuta orizzontale e regolare l'estensione agendo sul telescopico. Assicurarsi che le due lastre sia a piombo ed equidistanti sia in basso che in alto, questo potrebbe compromettere il corretto funzionamento delle ante.
 2. Serrare le viti per il fissaggio al vetro.
- La barra di tenuta orizzontale è fondamentale per la corretta tenuta del box doccia, garantisce resistenza alle sollecitazioni sui vetri fissi.

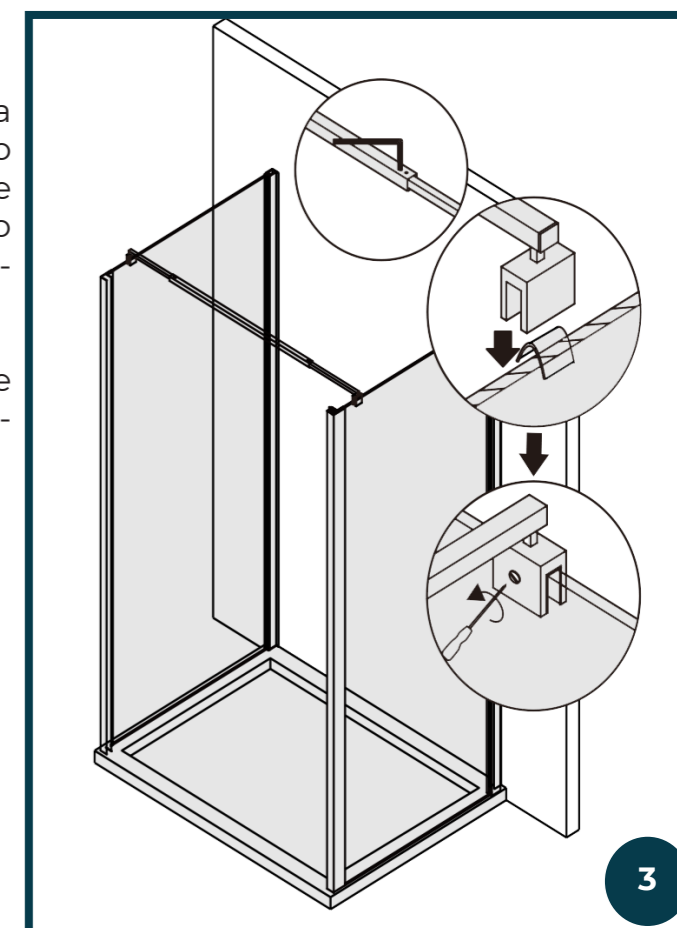

4° PASSAGGIO

1. Posizionare le cerniere sui vetri ed assemblare le due ante

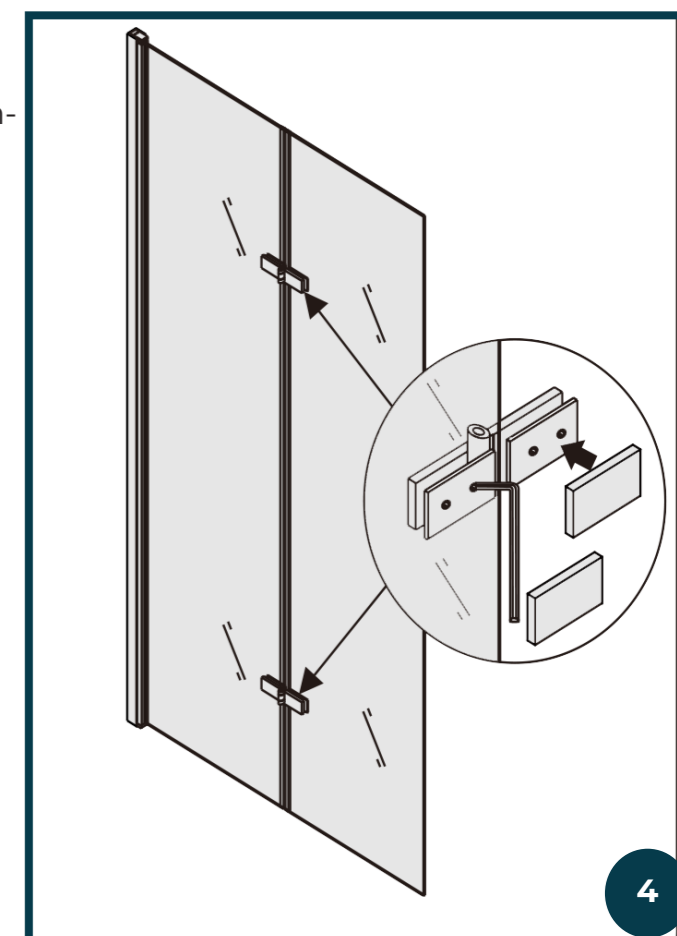

5° PASSAGGIO

1. Inserire la guarnizione calamita di chiusura
2. Posizionare le guarnizioni salvagoccia sagomandole, come in figura, per permettere una corretta chiusura della porta.

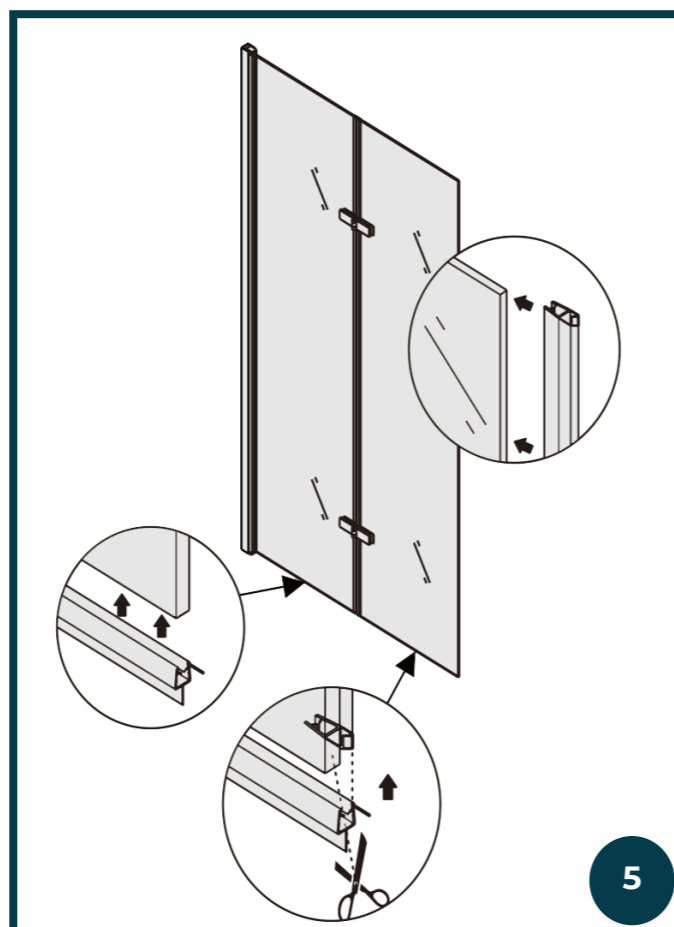
**6° PASSAGGIO**

1. Posizionare le porte nei profili ad angolo in alluminio

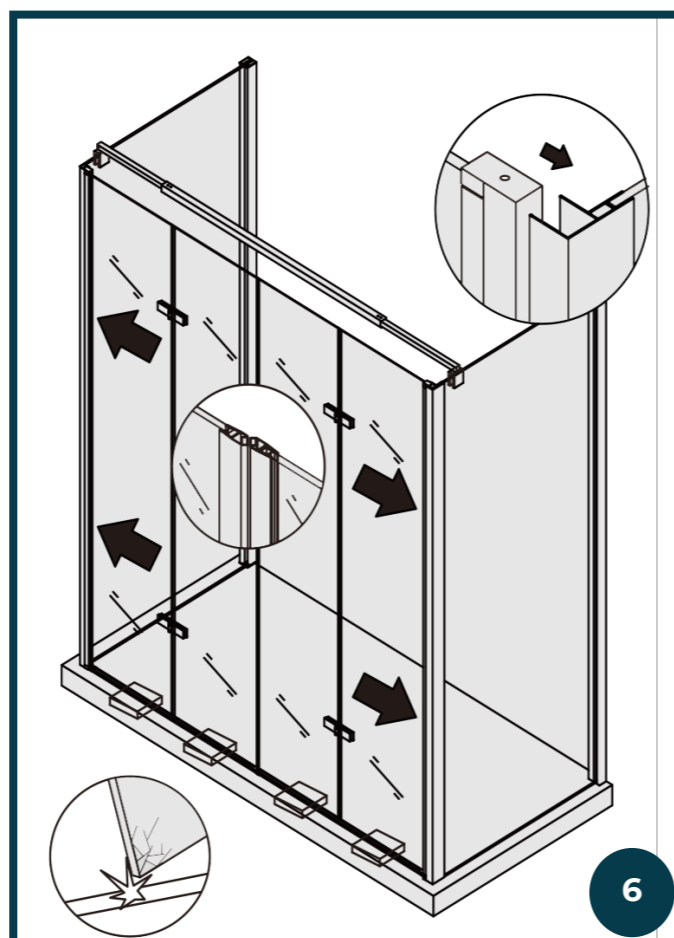
**7° PASSAGGIO**

1. Verificare la messa a piombo, quindi praticare dei fori dal lato interno e fissare il telaio con le viti al profilo ad angolo.
2. Usare i tappini cromati in dotazione per nascondere le viti di fissaggio della porta a libro dal lato interno.

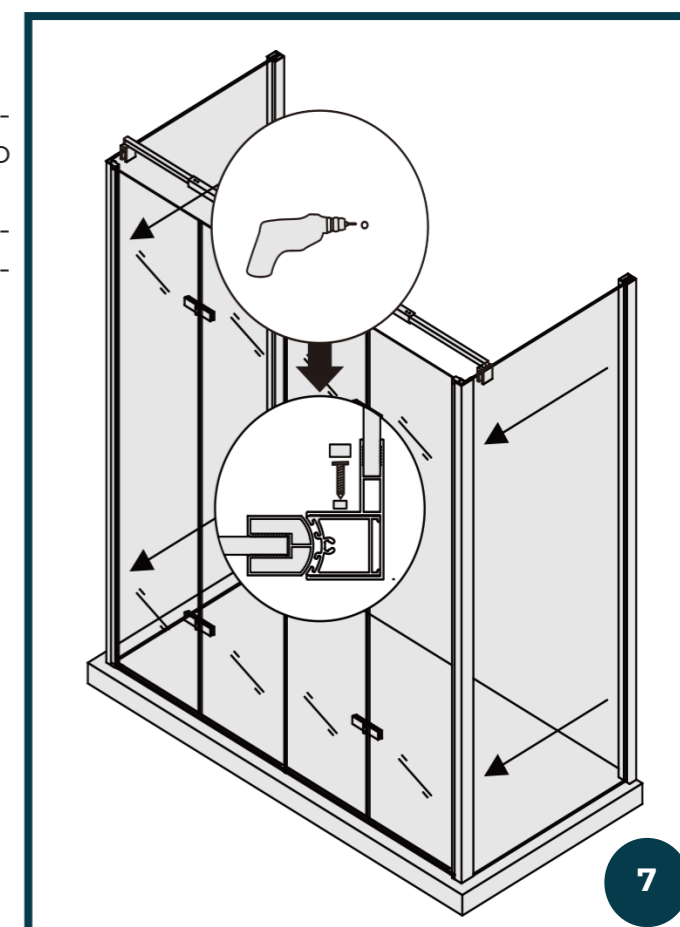
**8° PASSAGGIO**

1. Praticare dei fori dal lato interno dei profili a muro relativo alle pareti fisse.
2. Applicare le viti dal lato interno per bloccare le pareti fisse ai profili a muro.
3. Posizionare le cover decorative verticali di copertura ad incastro..

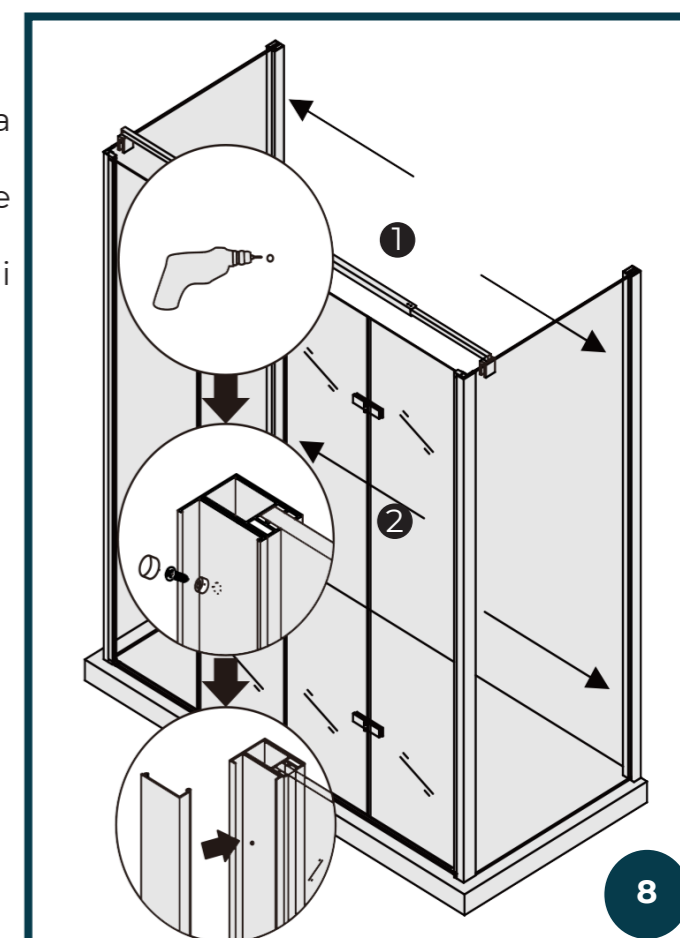

9° PASSAGGIO

1. Siliconare e posizionare la barra di tenuta inferiore.
2. Siliconare e posizionare i supporti di fissaggio sinistro e destro.

ATTENZIONE

Il corretto posizionamento della barra di tenuta inferiore e dei supporti di fissaggio sinistro e destro è quello indicato nella figura A, ovvero leggermente fuori dal telaio della porta onde evitare che dia fastidio alle ante e per garantire una corretta tenuta all'acqua.

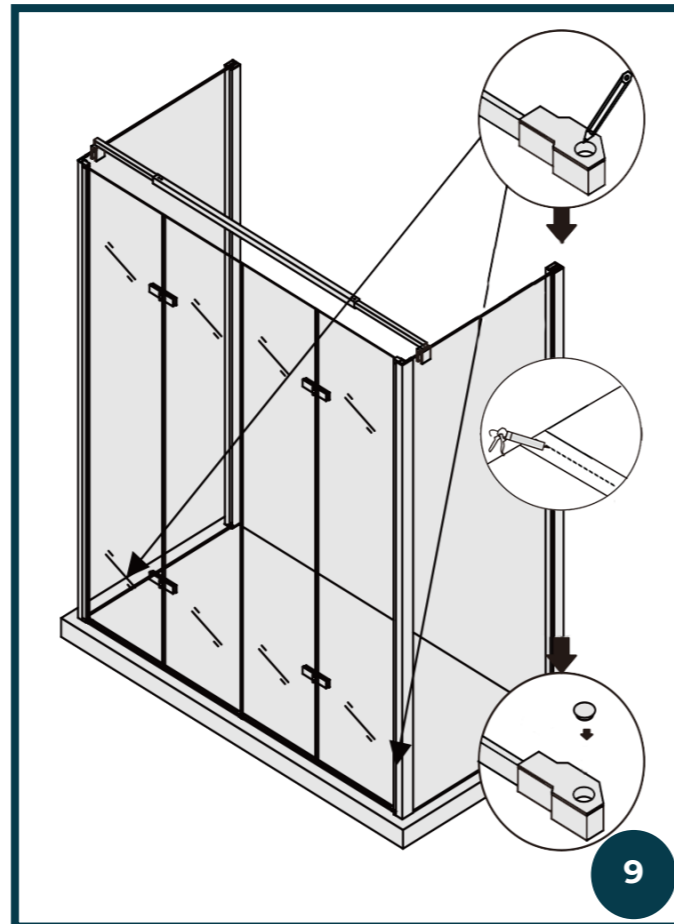
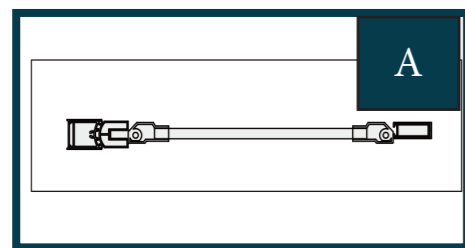
**10° PASSAGGIO**

1. Posizionare i supporti dei bracci di tenuta oblique a muro.
2. Tracciare i fori a muro con la matita.
3. Praticare i fori a muro con il trapano.
4. Inserire il tassello a muro e avvitare le viti per fissare il supporto.
5. Posizionare la Barra di tenuta sul vetro e avvitare le viti per il fissaggio.

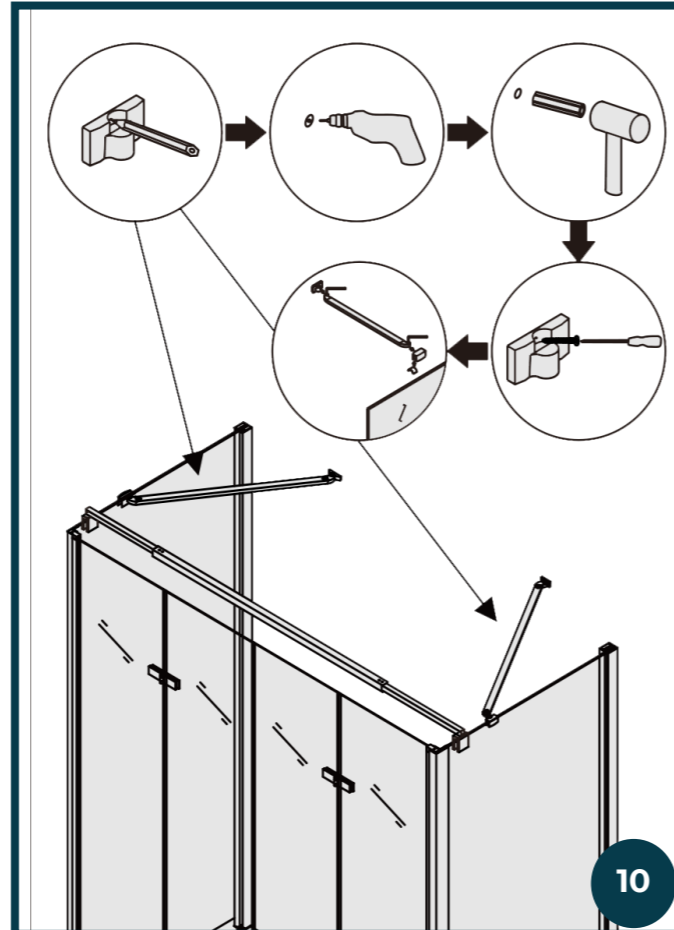
**11° PASSAGGIO**

1. Posizionare le guarnizioni ad aletta paraschizzi tra i due vetri come mostrato in figura.
2. Posizionare la Maniglia e fissarla al vetro

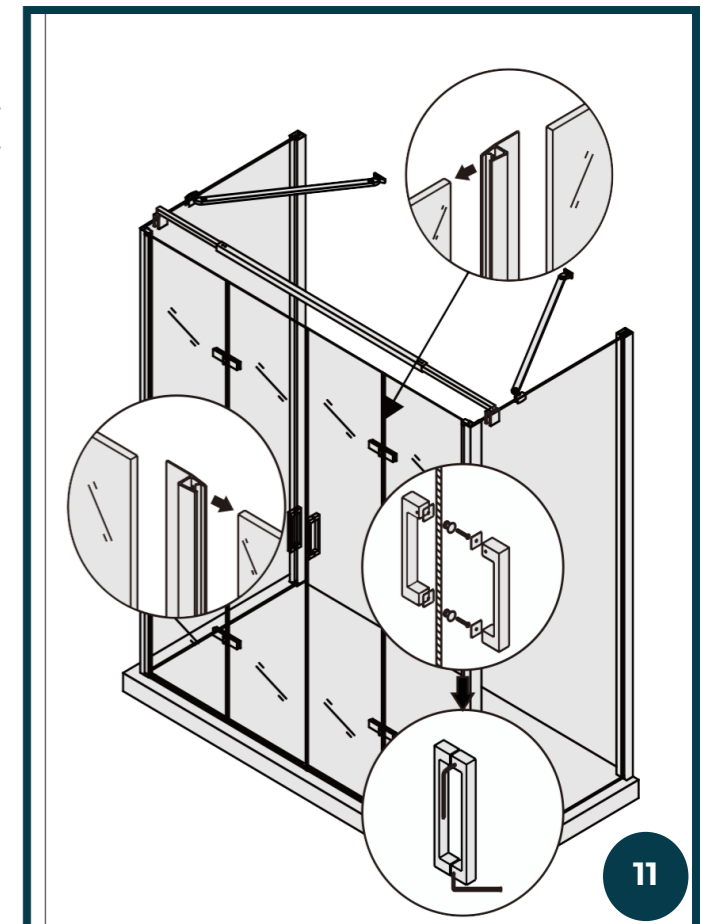
**12° PASSAGGIO**

1. Posizionare le cover di copertura superiore dei profili a muro sulle pareti fisse
 2. Siliconare il perimetro esterno del box doccia.
- Nota bene :
il profilo a muro della porta a libro ed il profilo ad angolo sono sprovvisti di cover superiori di copertura.

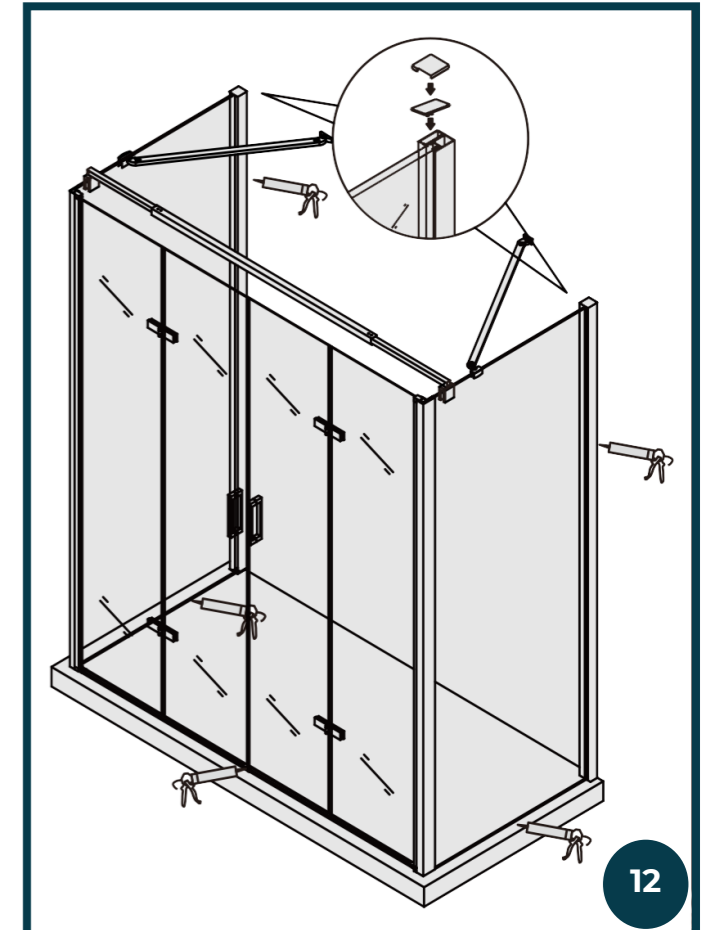

Laneri®

sanitary ware

c/da Gentilomo snc
94100 Enna Italy
www.laneribagni.it

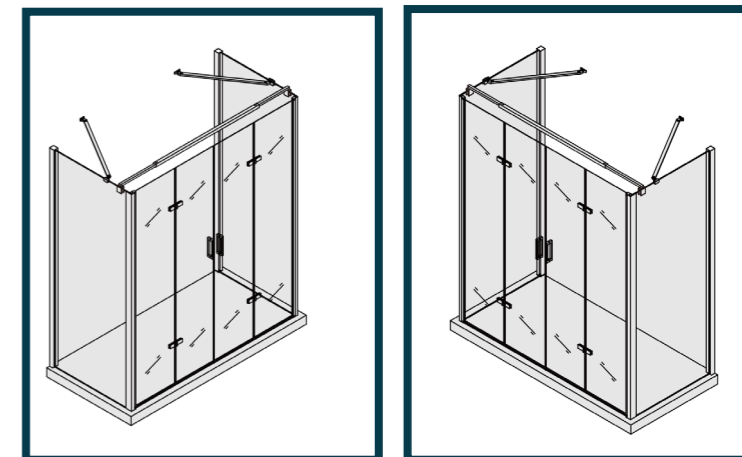

Buenos Aires 3.0

DESCRIPTION

Douche a trois côtés pliante avec entrée libre centrale. Hauteur 190 cm. Verre transparent trempé avec traitement anti-calcaire.

SPÉCIFICATION TECHNIQUE

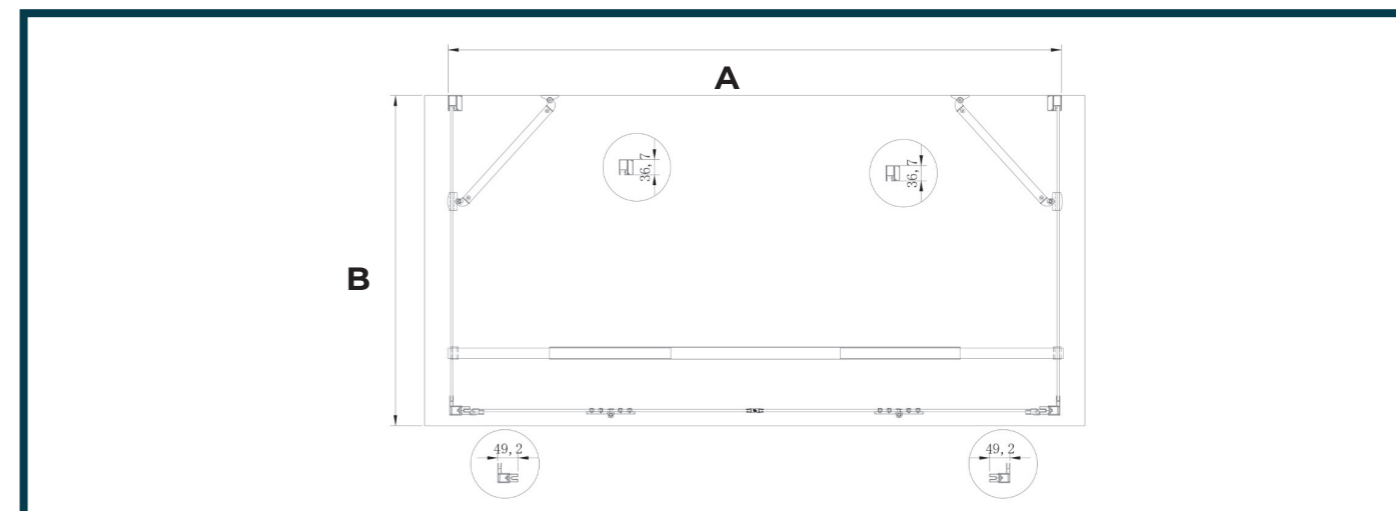

PROFILÉS EN DÉTAIL

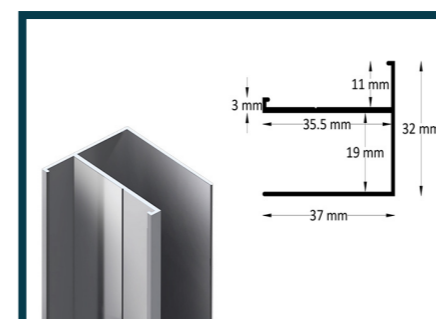

Profilé mural fixe

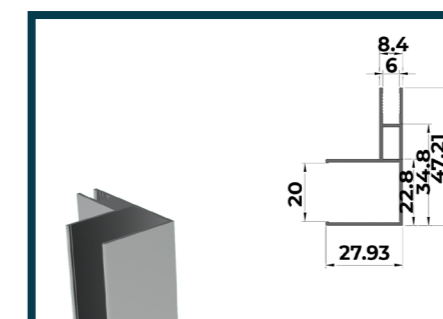

Profilé angulaire

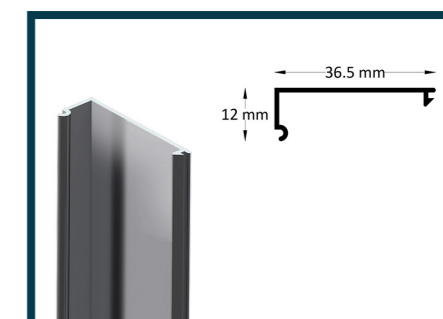

Profilé de couverture

Buenos Aires 3.0

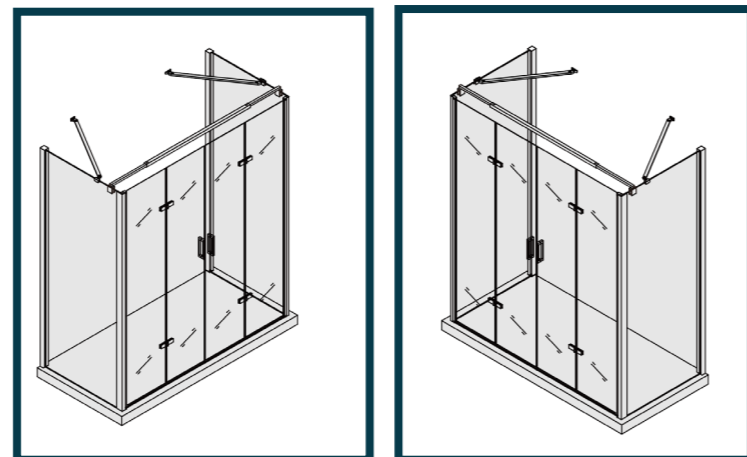

FICHE DE RÉGLAGE - CÔTÈ A

MODÈLE	MIN. CÔTÈ A	MAX.
110	1085	1120
120	1185	1220
130	1285	1320
140	1385	1420
150	1485	1520
160	1585	1620
170	1685	1720
180	1785	1820
190	1885	1920

FICHE DE RÉGLAGE - CÔTÈ B

MODÈLE	MIN. CÔTÈ B	MAX.
65	625	650
67,5	650	675
70	675	700
75	725	750
80	775	800

Buenos Aires 3.0

USTENSILES NECESSAIRES

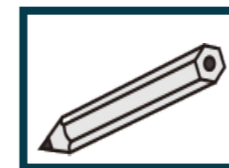

Crayon

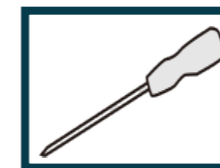

Tournevis

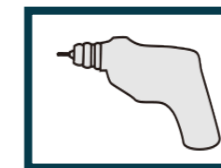

Forage

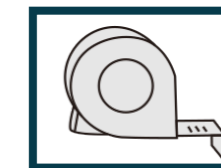

Ruban à mesurer

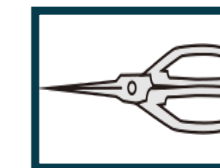

Ciseaux

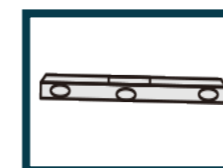

Niveau



Clé à douille
(en dotation)

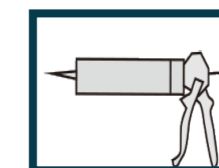

Silicone

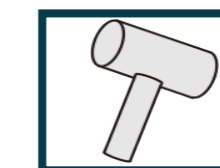

Maillet en ca-
outchouc

ACCESSOIRES INCLUS DANS LE COLIS

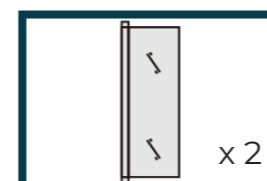

Verre transparent
6 mm x 2

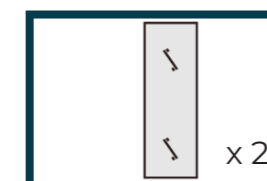

Verre transparent
6 mm x 2



Barre de soutien
pour la paroi fixe x 2

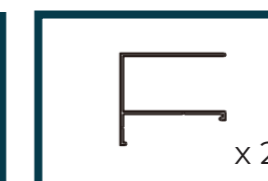

Profilé mural fixe x 2

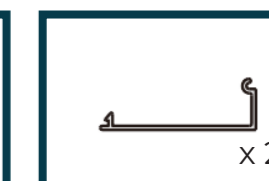

Profilé de couver-
ture x 2

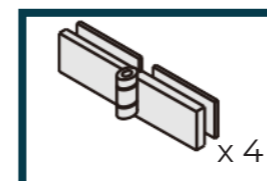

Charnières x 4

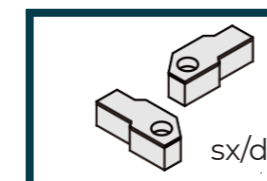

Support pour le
fixage sx/dx

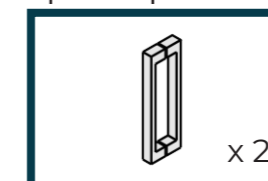

Poignée x 2



Barre de soutien
inférieur x 1



Joint d'étanchéité
avec ailette x 2



Joint magnétique x 2



Joint d'étanchéité x 4

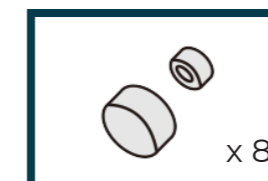

Joints et capu-
chons pour les vis x 8



Morceaux x 12



Vis 4 x 30 x 10

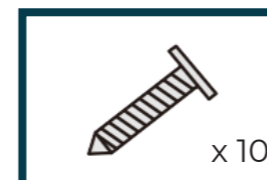

Vis 4 x 16 x 10

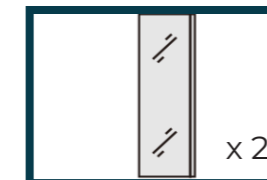

Verre de la paroi
fixe h 1.90 x 2

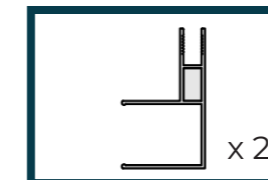

Profilé angulaire h
1.90 x 2

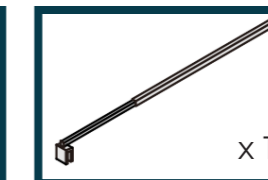

Barre de soutien
horizontale x 1

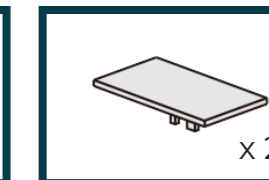

Couverture supérieur
pour bloquer le verre fixe x 2

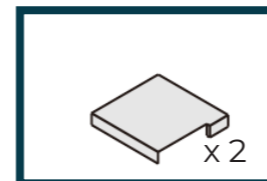

Couverture supérieur
du profilé mural x 2

MONTAGGIO

1^o ÉTAPE

1. Vérifiez le nivellement du receveur de douche avec le niveau.
2. Appuyez le profilé mural et utiliser le niveau pour la mise à plombe.
3. Tracer les trous sur le mur avec le crayon.
4. Faites le trous avec le forage.
5. Placez les morceaux et vissez les vis pour le fixer sur la paroi.

IMPORTANT:

Nous recommandons de pas installer le profilé à proximité du bord extérieur du receveur de douche, mais de laisser au moins 1 cm du bord, pour une installation optimale.

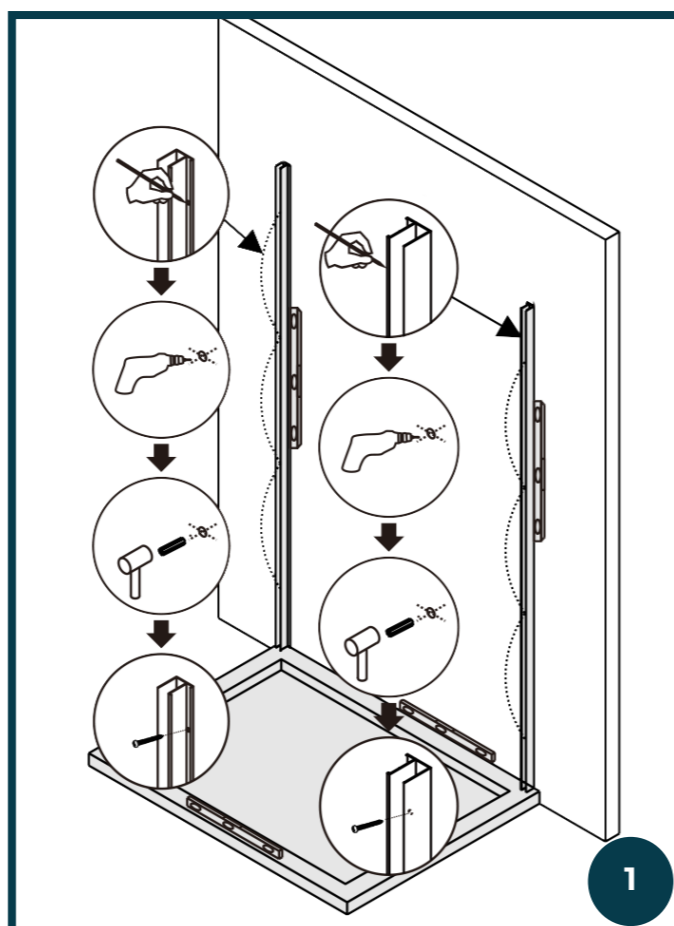
2^o ÉTAPE

1. Appliquez le silicone dans le profilé angulaire. Insérez le verre fixe dans le profilé angulaire.
2. Installez les parois fixe sur le mur.

IMPORTANTE:

Pour une correct installation, nous recommandons de supprimer le profilé murale de la paroi et de inserer-t-il sur les parois fixes en verre. Appuyez-t-elles sur le receveur. Vous irez à fixer le profilé ensuite.

ATTENTION:

Les parois de verre n'ont pas du châssis ou joints sous-verre. Ils doivent être appuyé sur le receveur. Après, mettez du silicone par l'extérieur.

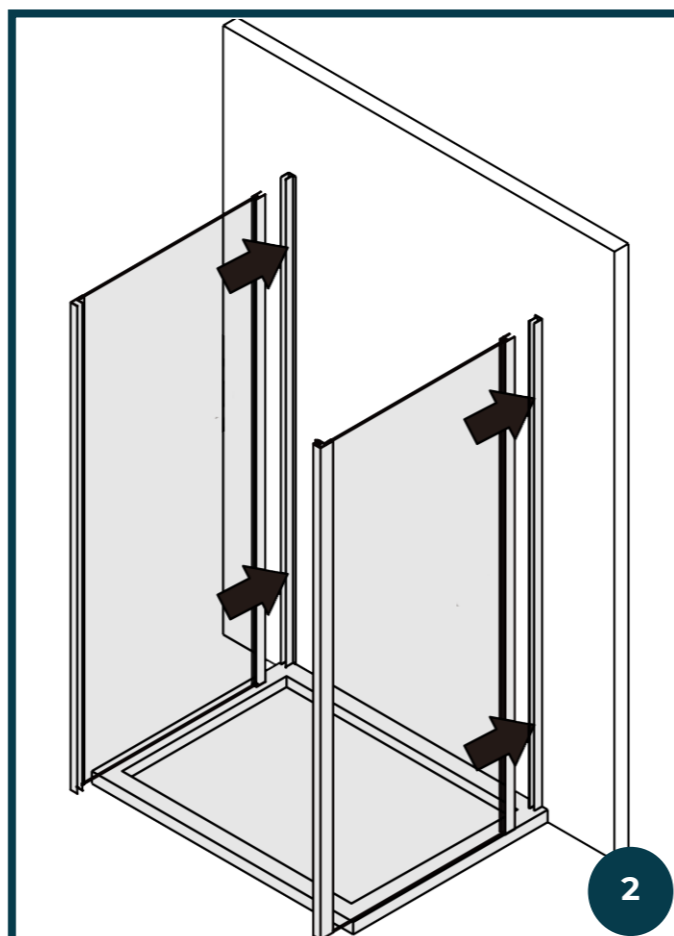
3^o ÉTAPE

1. Positionnez entre les deux verres la barre d'étanchéité horizontale et réglez l'extension. Vérifiez que le verres soient à plombe et qu'ils soient équidistant en bas et en haut.
2. Visser les vis pour le fixage au verre.

La barre d'étanchéité horizontale est très importante pour une plus grande robustesse de la douche.

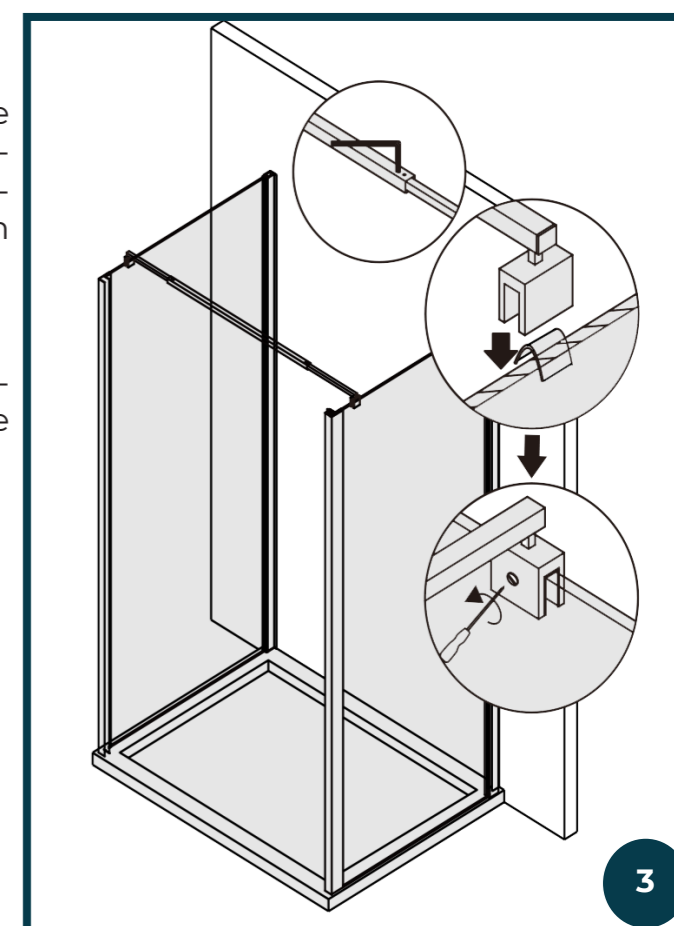
4^o ÉTAPE

1. Positionnez les charnières sur le verre 6 mm relatif à la porte et fixez-t-elles sur le verre selon l'illustration

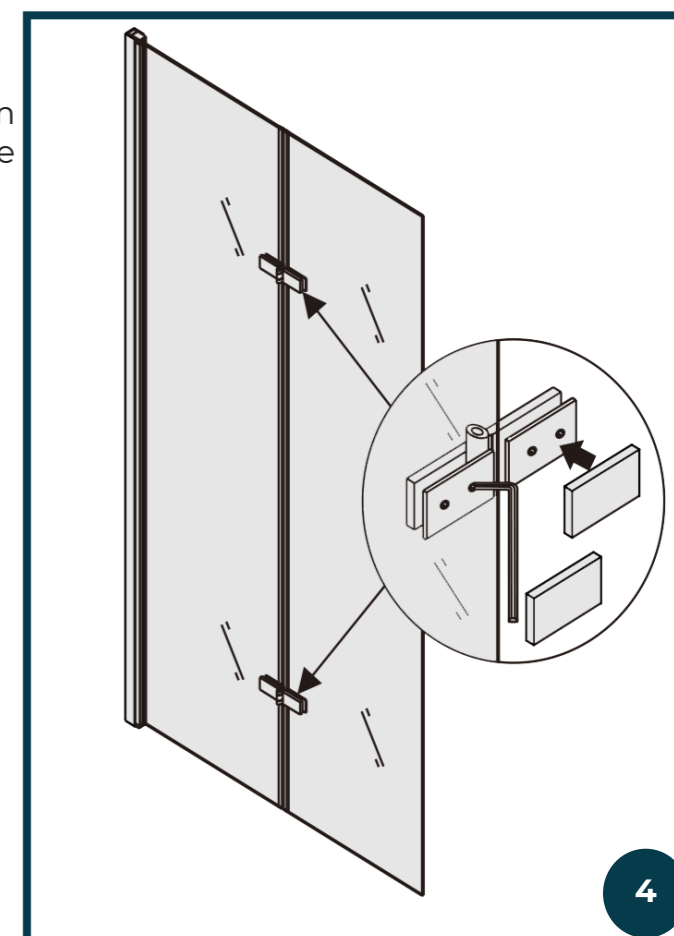

5° ÉTAPE

1. Insérez le joint à magnet
2. Positionnez le joint d'étanchéité en le façonnant, selon l'illustration, pour favoriser la correct fermeture de la porte et pour une optimale étanchéité de l'eau.

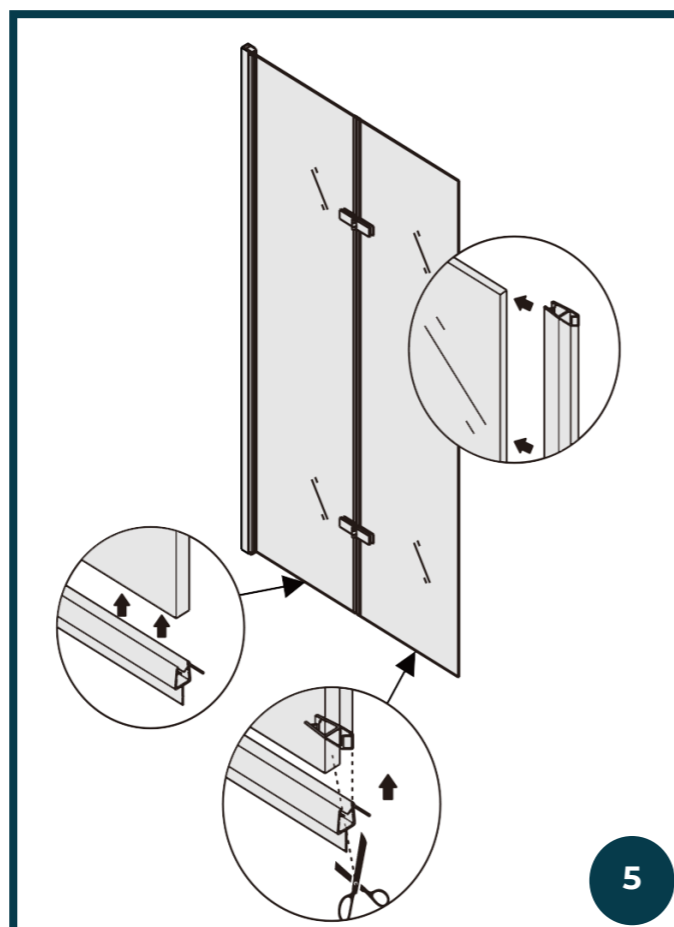
**6° ÉTAPE**

1. Positionnez les portes dans le profilées en aluminium

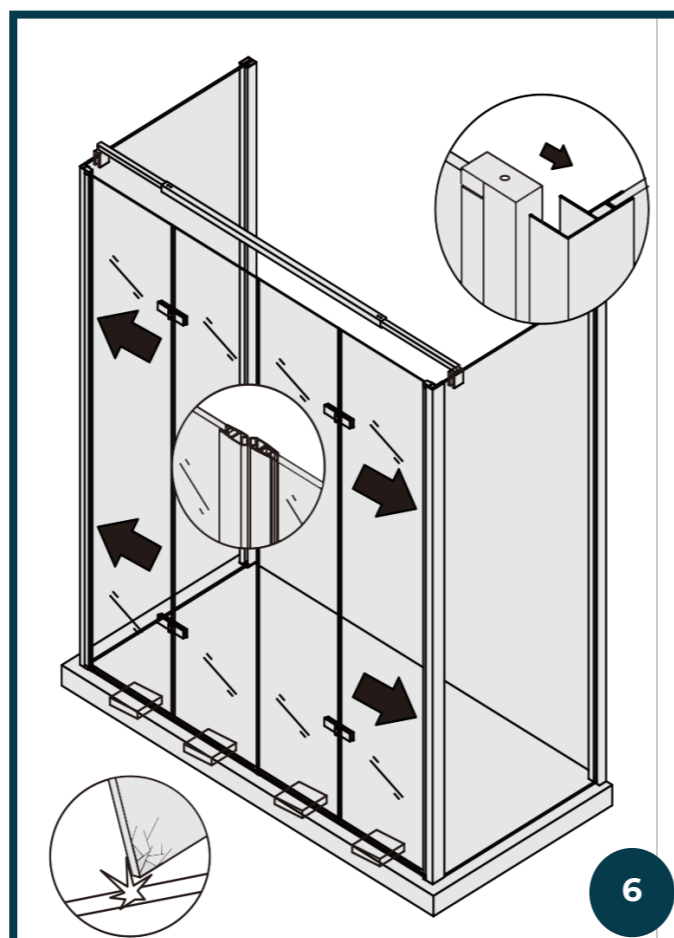
**7° ÉTAPE**

1. Vérifiez la mise à plombe de la porte et faites le trous pour fixer le profilé à la paroi.
2. Appliquez les vis et le support par la partie intérieure pour fixer les parois fixes de la douche au profilé mural. Couvrez les vis avec les relatif caopuchons chromé.

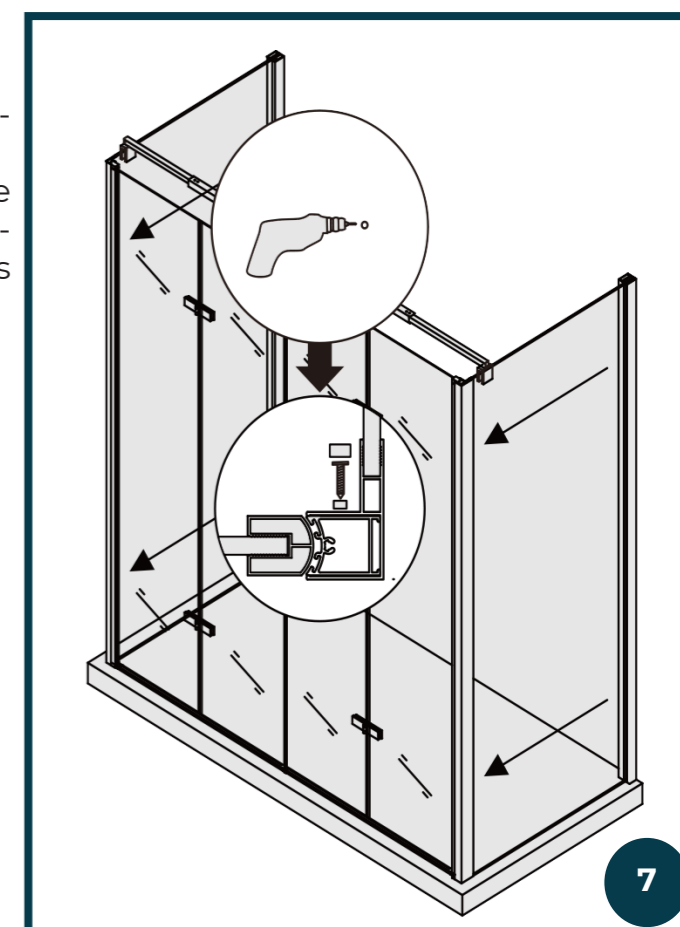
**8° ÉTAPE**

1. Faites les trous par la côté intérieur du profilé murale relatif à la paroi fixe.
2. Appliquez les vis par la côté intérieur pour bloquer la paroi fixe au profilée murale.
3. Positionnez la couverture décoratif long l'hauteur à emboîtement.

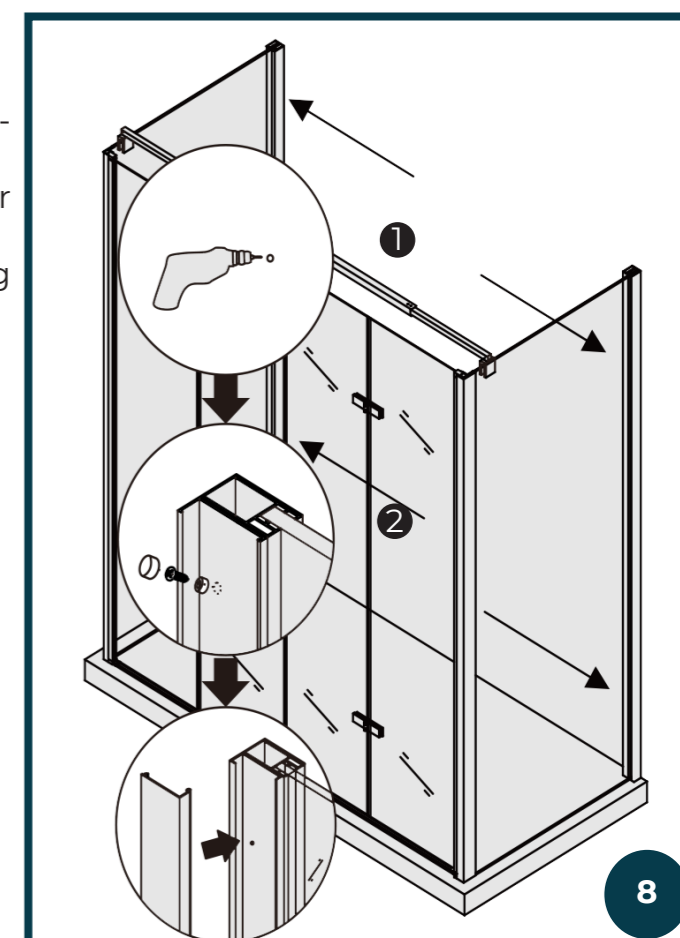

9° ÉTAPE

1. Mettez le silicone et positionnez la barre de soutienne inférieur.
2. Mettez le silicone et positionnez les supports (à droit et à gauche) pour le fixage.

ATTENTION

Le correct positionnement de la barre d'étanchéité inférieure et des supports (droit et gauche) est montré dans l'illustration "A", c'est à dire, un petit peu hors du châssis de la porte. Cela pour favoriser une maximale étanchéité.

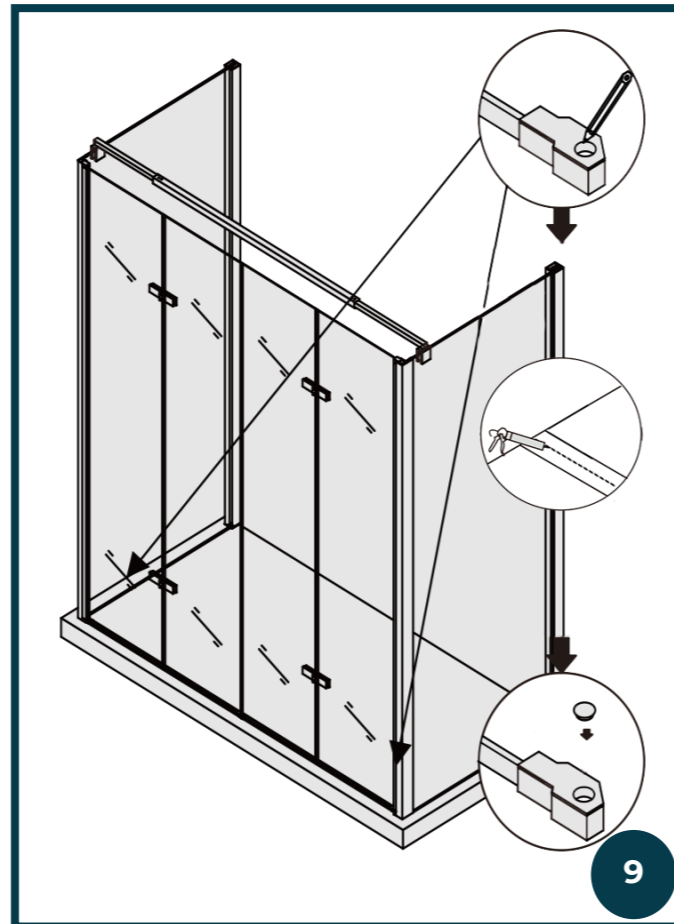
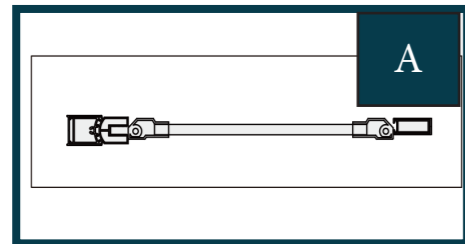

10° ÉTAPE

1. Positionnez le support de les barres obliques à la paroi
2. Traquez les trous sur la paroi avec le crayon.
3. Faites les trous sur la paroi avec le forage.
4. Inserez les morceau sur la paroi et vissez le vis pour les fixer.
5. Positionnez la barre d'étanchéité horizontale sur la paroi fixe et vissez les vis pour fixer-t-il au verre.

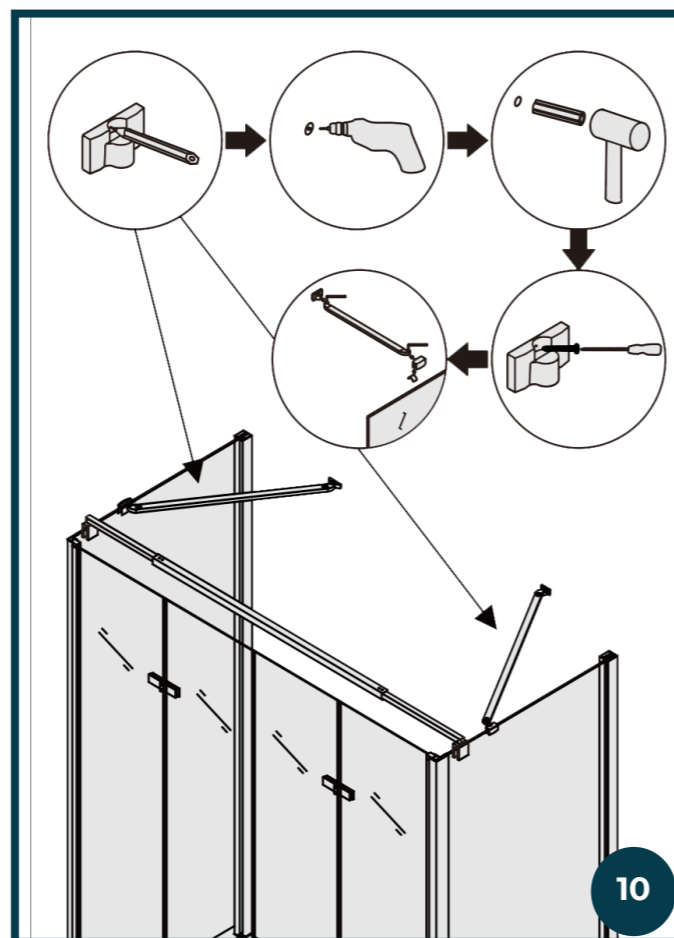

11° ÉTAPE

1. Positionnez les joints avec l'ailette entre les deux verres selon l'illustration.
2. Positionnez le poignée et fixez-t-elle au verre.

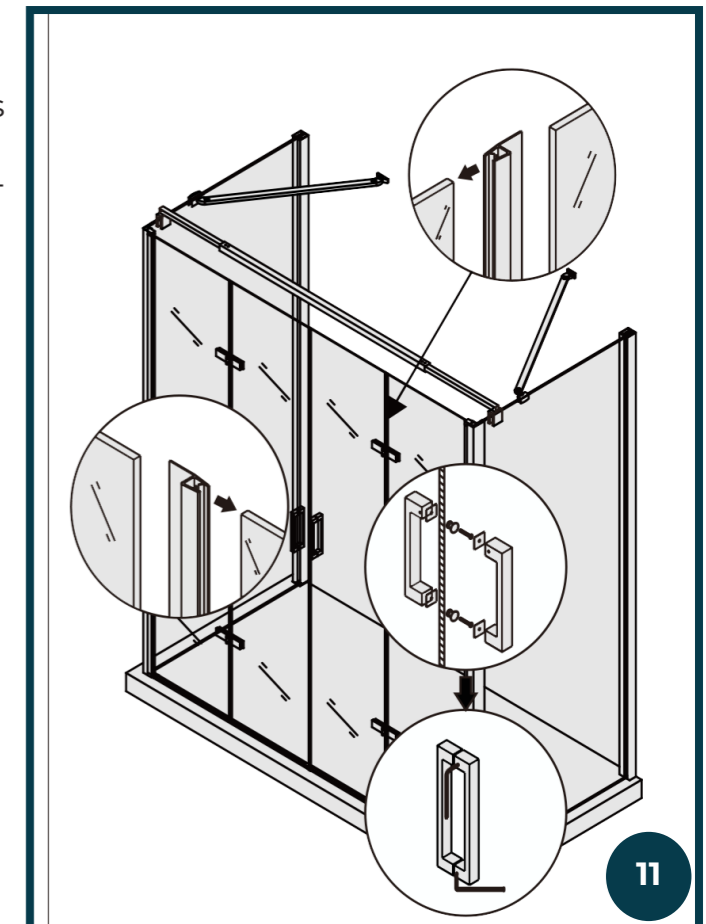

12° ÉTAPE

1. Positionnez la couverture decoratif sur la la côté supérieur du profilé mural relatif à la paroi fixe.
2. Mettez le silicone tout autour du périmètre de la douche.

IMPORTANTE:

Le profilé mural de la porte pliante et les profilé angulaire n'ont pas des couvertures supérieur.

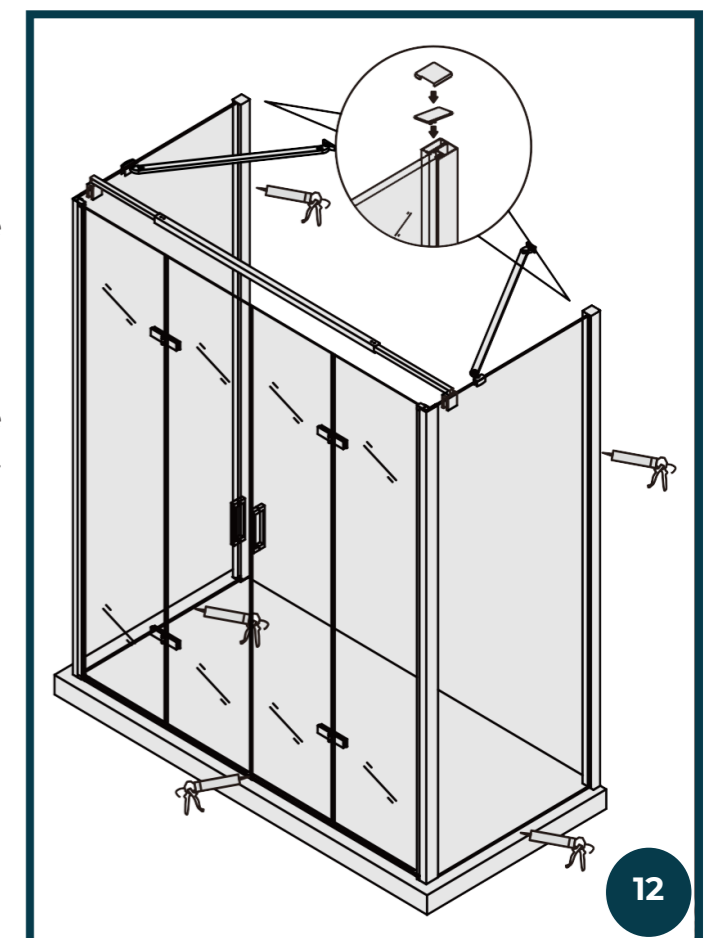

Laneri®

sanitary ware

c/da Gentilomo snc
94100 Enna Italy
www.laneribagni.it

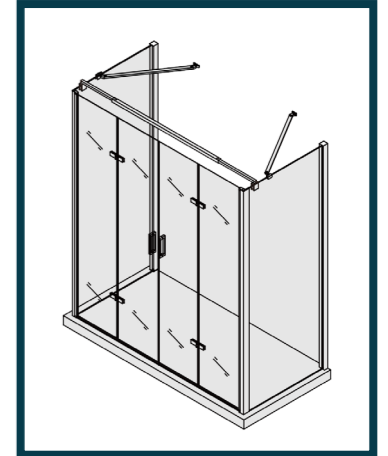
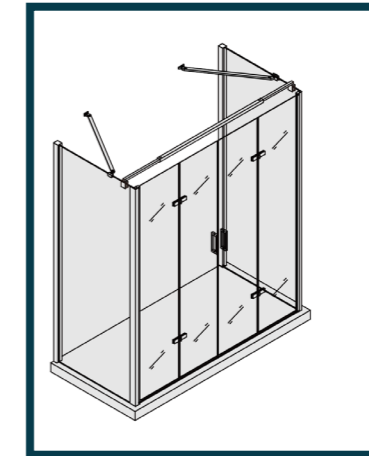

Buenos Aires 3.0

BESCHREIBUNG

Dreiseitige Duschkabine mit Doppeltür mit 4 ausklappbaren Flügeltüren mit vollständiger Öffnung und geräumigem Zugang kombiniert mit zwei festen Seitenwänden. Höhe 190 cm.
6 mm gehärtetes Glas mit pflegeleichter Anti-Kalk-Behandlung

TECHNISCHE BESCHREIBUNG

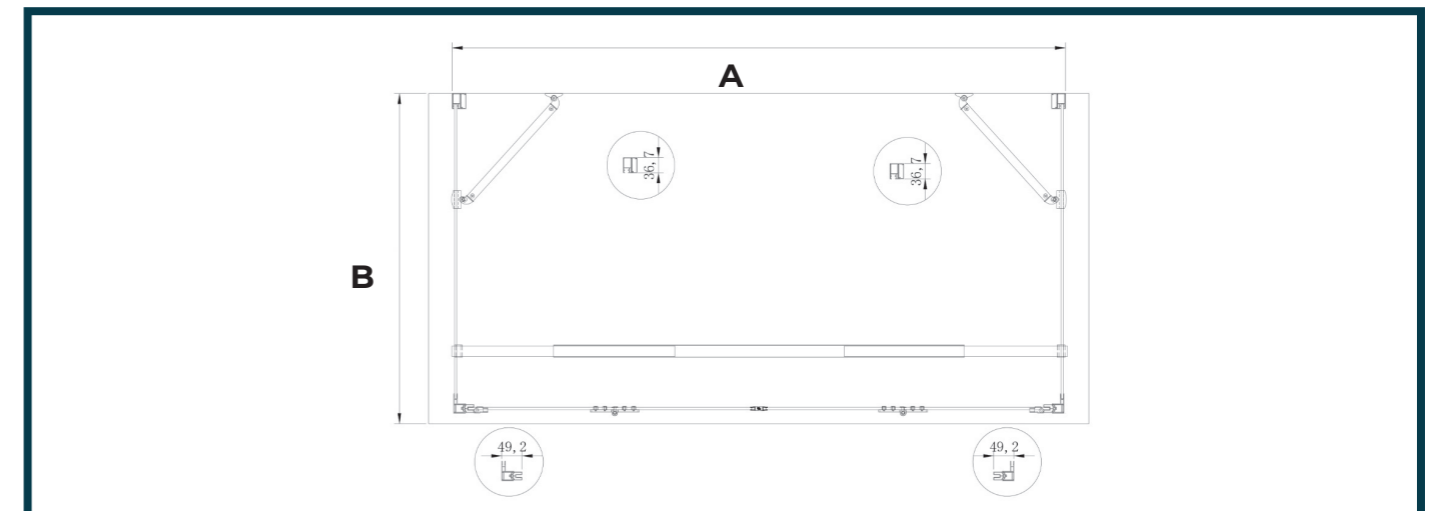

DETAILS ZUBEHÖR

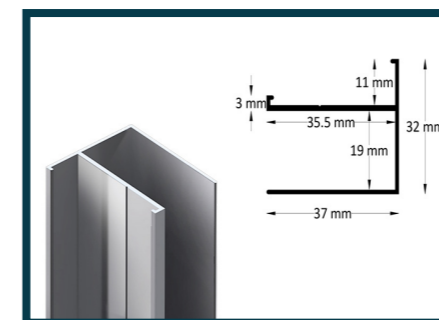

Festes Wandelement

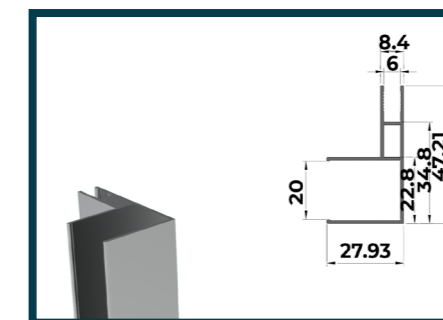

Eckelement

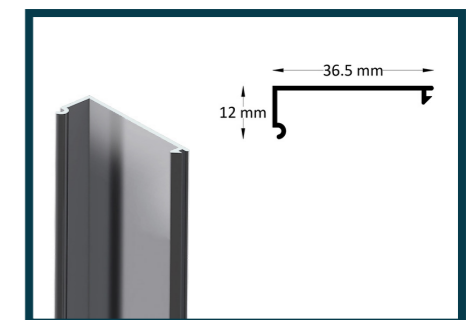

Abdeckelement

Buenos Aires 3.0



TABELLE ZUR EINSTELLUNG SEITE A

MODELL	ABMESSUNGEN A	
	MIN.	MAX.
110	1085	1120
120	1185	1220
130	1285	1320
140	1385	1420
150	1485	1520
160	1585	1620
170	1685	1720
180	1785	1820
190	1885	1920

TABELLE ZUR EINSTELLUNG SEITE B

MODELL	ABMESSUNGEN A	
	MIN.	MAX.
65	625	650
67,5	650	675
70	675	700
75	725	750
80	775	800

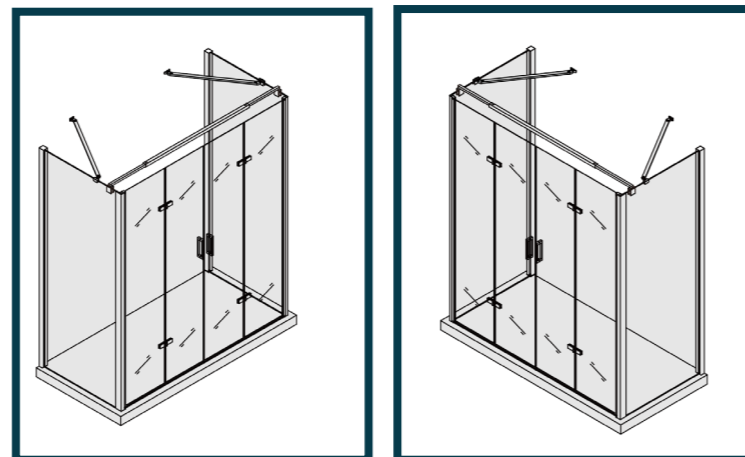
Buenos Aires 3.0

BENÖTIGTE WERKZEUGE

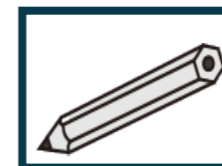

Bleistift

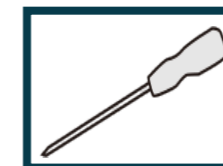

Schraubendreher

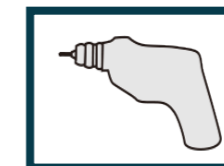

Bohrer

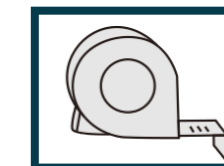

Maßband

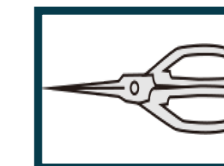

Schere

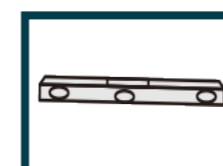

Wasserwaage



Sechskantschlüssel
(mitgeliefert)

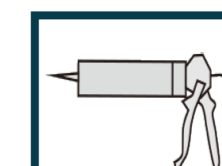

Silikon

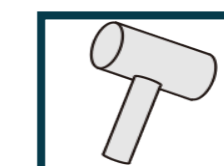

Gummihammer

PAKETINHALT

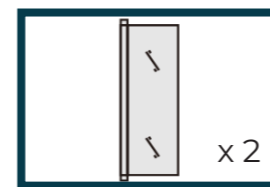

6 mm dickes Glas
auf der Türseite x 2

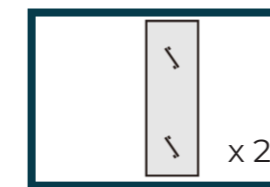

6 mm dickes Glas auf
der Schließseite der Tür x 2



Abdichtungsschiene
für feste Glaswand x 2



Wandelement H
1,90 x 2



Wandelementab-
deckung H 1,90 x 2

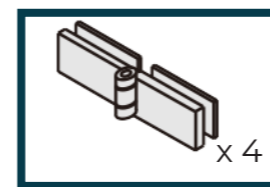

Scharnier x 4

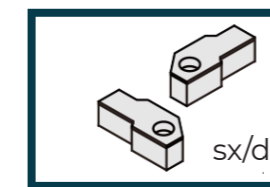

Befestigungsstützen
sx/dx

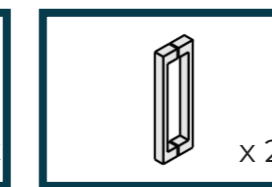

Griffe x 2



Untere Dichtung-
leiste x 1



Spritzschutz-
dichtung x 2



Magnetdichtung x 2

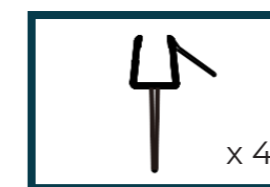

Duschdichtung x 4

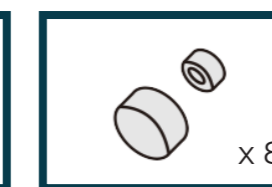

Dichtungen und Kap-
pen für Schrauben x 8

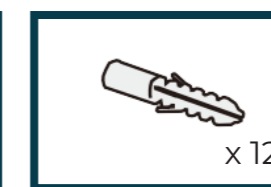

Dübel x 12



Schrauben 4 x 30 x 10

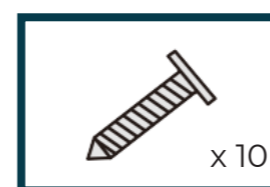

Schrauben 4 x 16 x 10

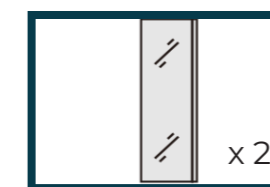

Feste Glaswand
H 1,90 x 2

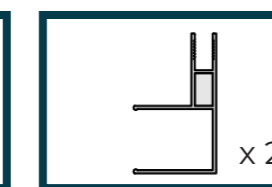

Winkelement
H 1,90 x 2

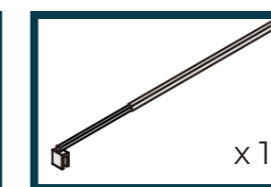

Horizontale Halte-
stange x 1

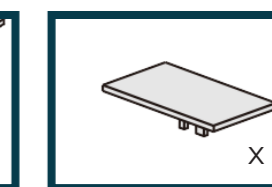

Obere Abdeckung mit
festem Glasanschlag x 2

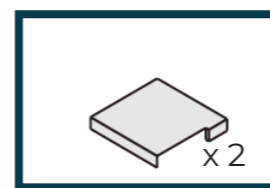

Obere Wandele-
mentabdeckung x 2

MONTAGGIO

1. SCHRITT

1. Stellen Sie mit Hilfe der Wasserwaage sicher, dass die Duschwanne eben ist.
2. Platzieren Sie das Element an der Wand und verwenden Sie die Wasserwaage zum senkrechten Stellen.
3. Markieren Sie die Löcher mit dem Bleistift auf der Wand.
4. Bohren Sie mit dem Bohrer die Löcher in die Wand.
5. Setzen Sie den Dübel ein und schrauben Sie die Schrauben fest, um das Element zu befestigen.

WICHTIG

Es wird empfohlen, die Elemente nicht direkt an der Außenkante der Duschwanne anzubringen, immer etwa 1 cm Abstand lassen für ein optimales ästhetisches Ergebnis

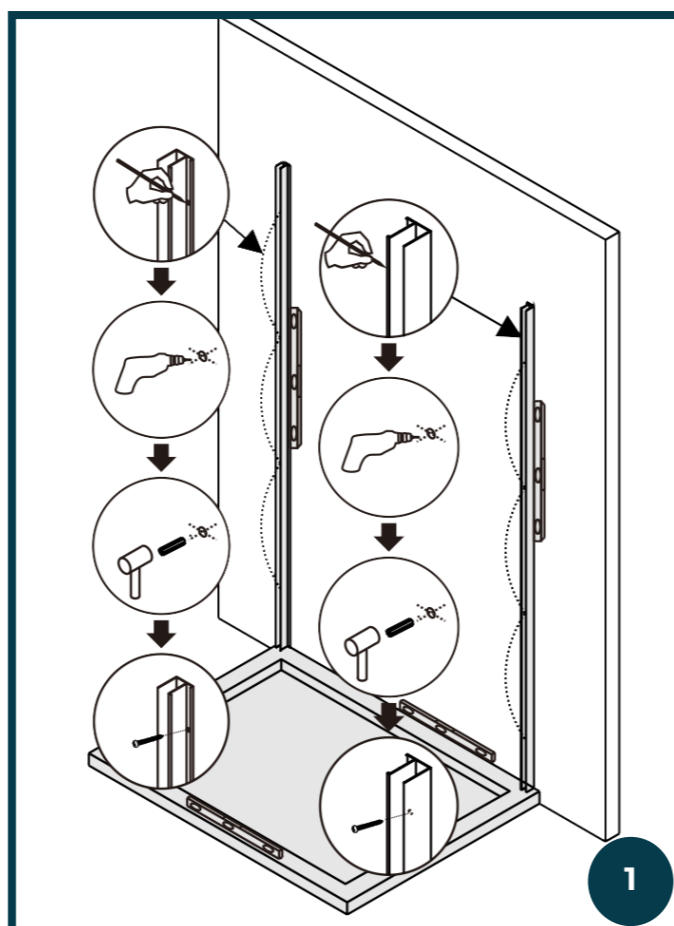

2. SCHRITT

1. Am Eckprofil an den festen Wänden Silikon auftragen und warten, bis das Silikon zwischen Glas und Aluminium greift.
2. Positionieren der festen Wände an den Wandprofilen Empfehlung

Entfernen Sie die Wandprofile von der Wand, setzen Sie diese in die festen Wände ein und ordnen Sie alles erneut an der Wand an, die Bedienung wird dadurch einfacher.

BITTE BEACHTEN SIE:

Die festen Platten haben unten keinen Rahmen und/oder Dichtung, sie müssen vorzugsweise von außen auf die Duschwanne gelegt und mit Silikon befestigt werden.

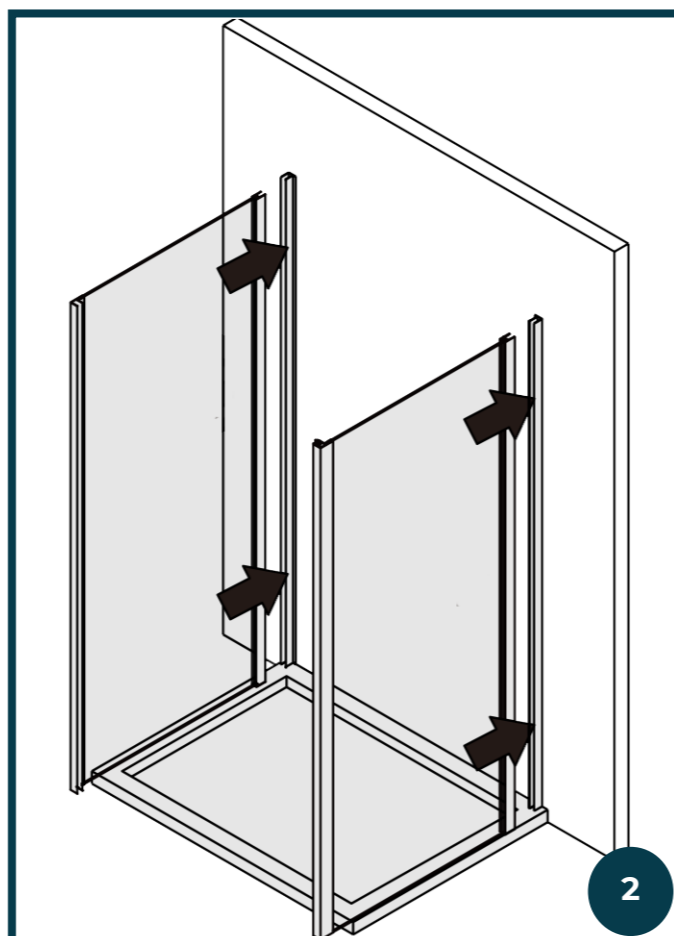

3. SCHRITT

1. Legen Sie die horizontale Haltestange zwischen beide Glaselemente und stellen Sie die Länge durch das Verstellen der Duschstange ein. Stellen Sie sicher, dass die beiden Platten im Lot sind und sowohl unten als auch oben gleich weit voneinander entfernt sind, da dies die ordnungsgemäße Funktion der Türen beeinträchtigen könnte.
2. Ziehen Sie die Schrauben zur Befestigung am Glas fest.

Die horizontale Haltestange ist für die korrekte Abdichtung der Duschkabine unerlässlich, sie garantiert die Widerstandsfähigkeit des feststehenden Glases.

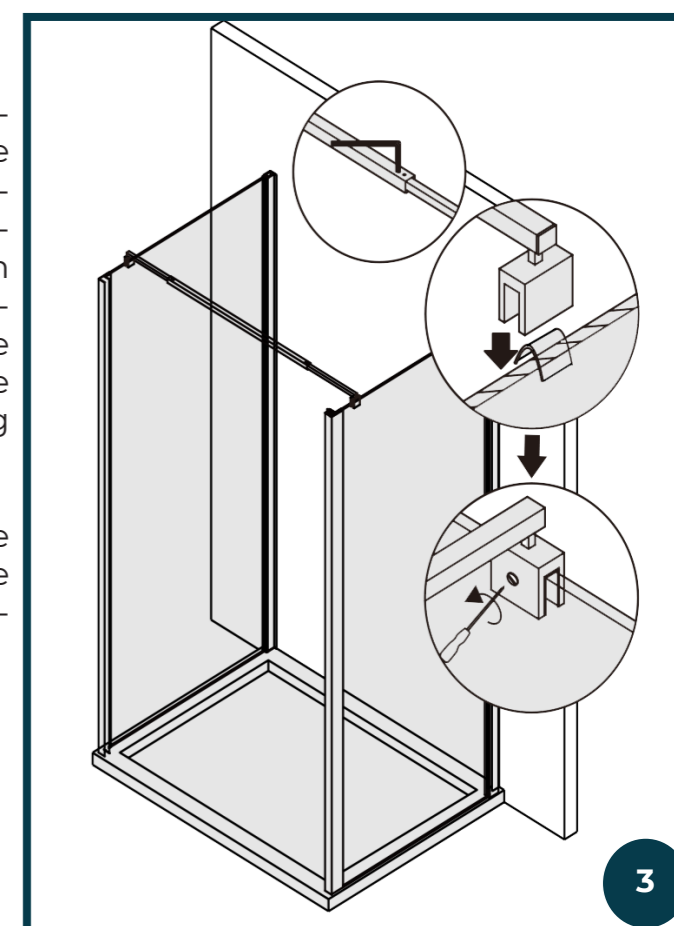

4. SCHRITT

1. Legen Sie die Scharniere auf der Türseite auf das 6 mm dicken Glas und befestigen Sie sie wie in der Abbildung gezeigt am Glas.

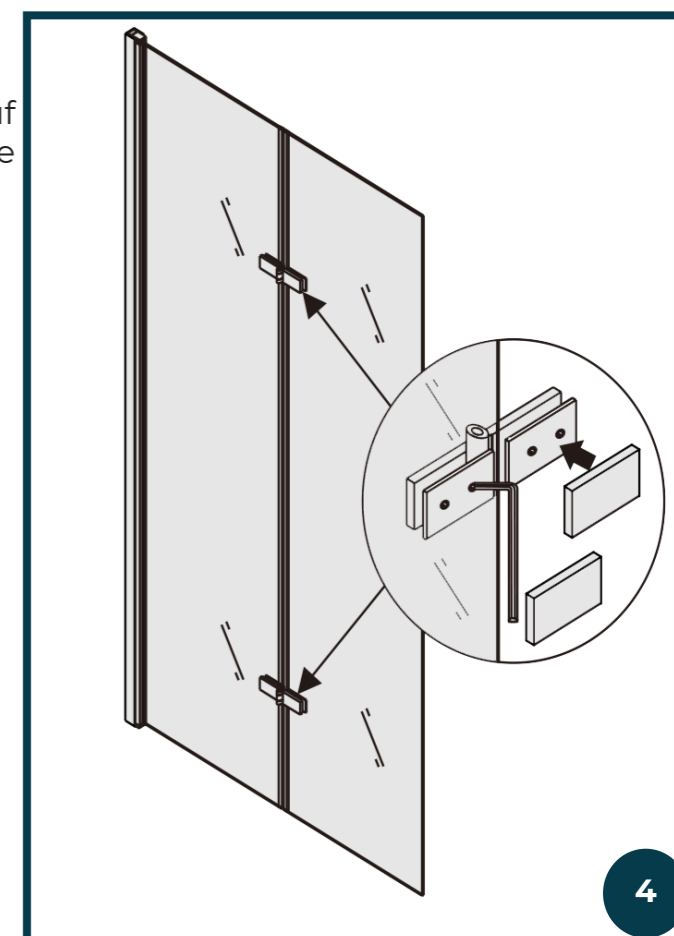

5. SCHRITT

1. Setzen Sie die Magnetdichtung ein.
2. Formen Sie die Duschdichtung wie in der Abbildung gezeigt und setzen Sie sie so ein, dass ein korrektes Schließen der Tür und eine vollständige Abdichtung erreicht wird.

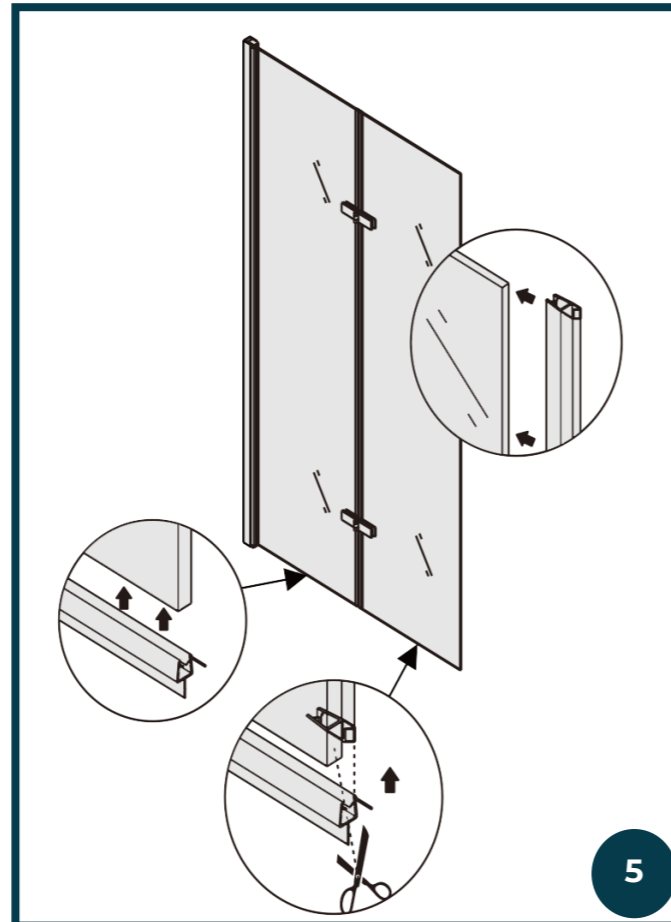

5

6. SCHRITT

1. Setzen Sie die Türen in die Eckprofile aus Aluminium ein

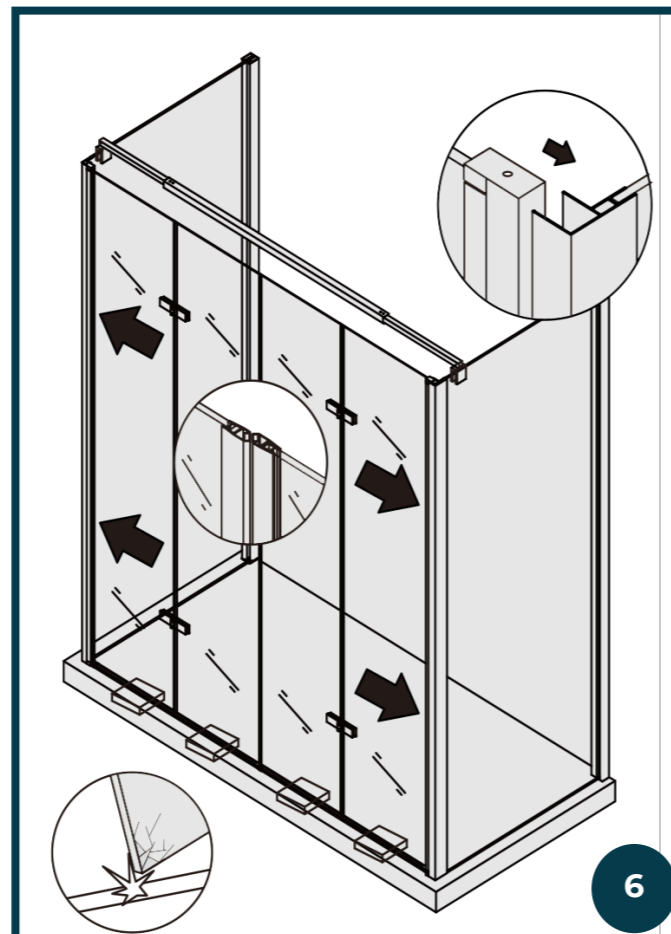

6

7. SCHRITT

1. Überprüfen Sie das Lot, anschließend von innen Löcher bohren und den Rahmen mit dem Eckprofil verschrauben.
2. Verwenden Sie die mitgelieferten Chromkappen, um die Befestigungsschrauben der Falttür innen zu verbergen.

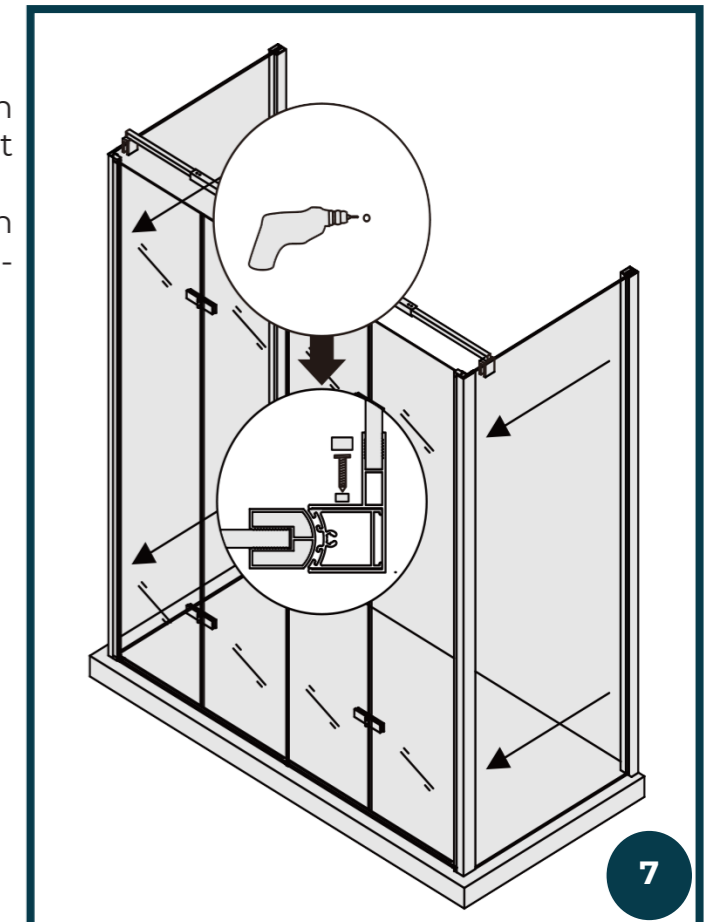

7

8. SCHRITT

1. Bohren Sie an der Innenseite der Wandprofile zu den relativen festen Wänden Löcher.
2. Bringen Sie die Schrauben von innen an, um die festen Wände an den Wandprofilen zu befestigen.
3. Positionieren Sie die vertikalen dekorativen Abdeckungen an der Einspannung.

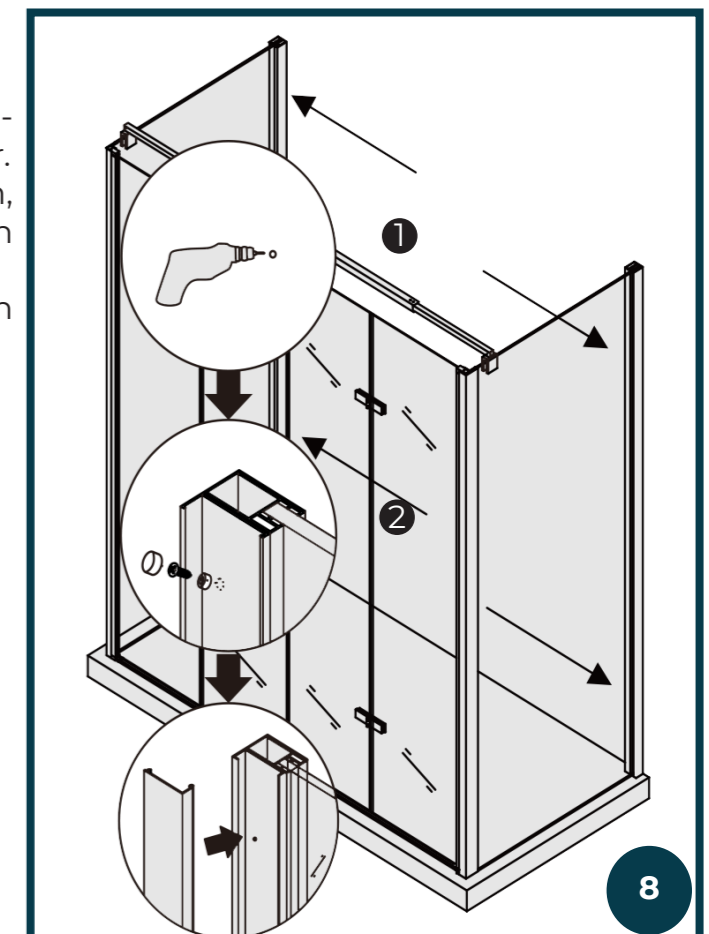

8

SCHRITT 9

1. Bringen Sie die untere Dichtungsleiste mit Silikon an.
2. Bringen Sie die linken und rechten Befestigungsstützen mit Silikon an.

ACHTUNG

Die korrekte Positionierung der unteren Dichtungsleiste und der linken und rechten Befestigungsstützen ist wie in Abbildung A dargestellt, d. h. etwas außerhalb des Türrahmens, um eine Behinderung der Türflügel zu vermeiden und eine vollständige Dichtigkeit zu gewährleisten.

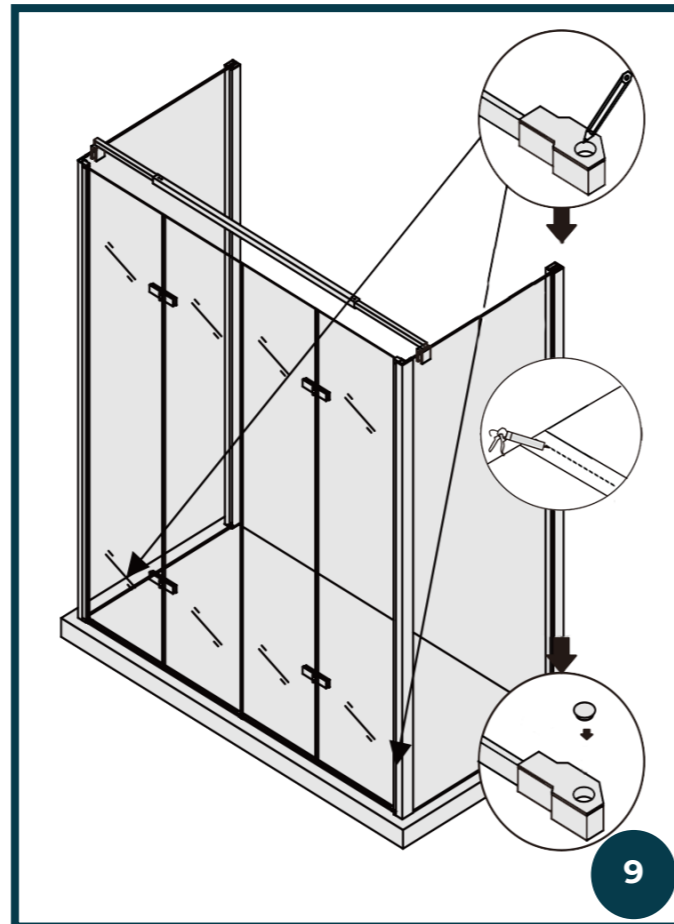
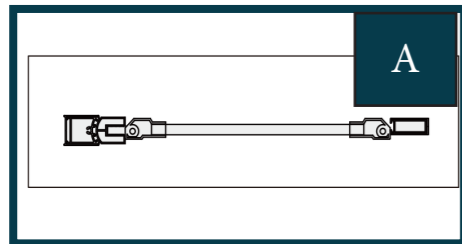

10. SCHRITT

1. Positionieren Sie die Stützen der schrägen Haltearme an der Wand.
2. Markieren Sie die Löcher in der Wand mit dem Bleistift.
3. Bohren Sie mit dem Bohrer die Löcher in die Wand.
4. Setzen Sie den Dübel ein und schrauben Sie die Schrauben fest, um das Element zu befestigen.
5. Setzen Sie die Haltestange auf das Glas und schrauben Sie die Schrauben zur Befestigung ein.

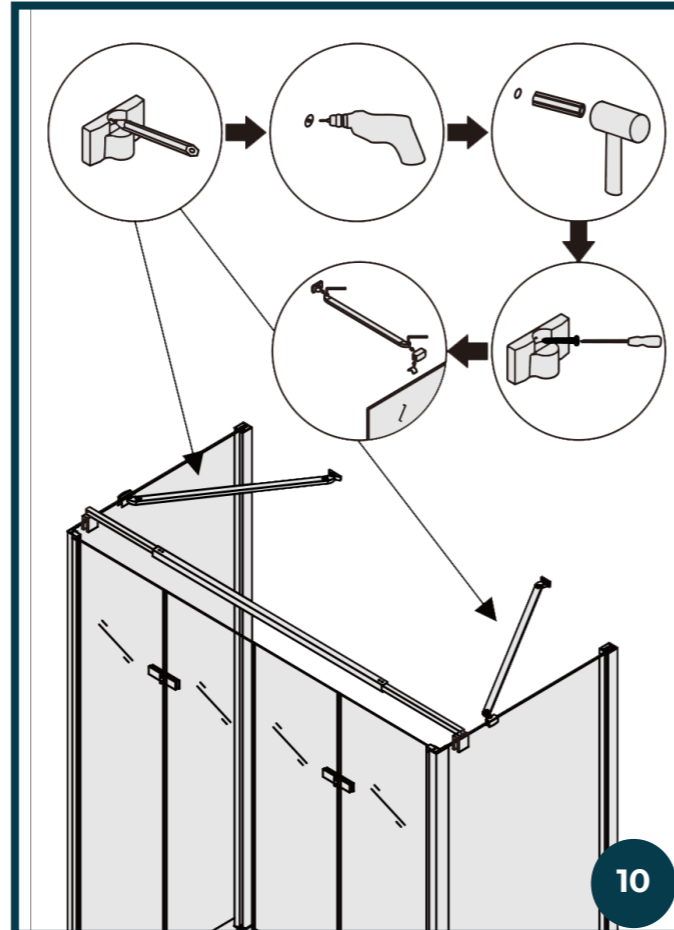

11. SCHRITT

1. Positionieren Sie die Spritzschutzdichtungen zwischen den beiden Gläsern, wie in der Abbildung gezeigt.
2. Positionieren Sie den Griff und befestigen Sie diesen am Glas.

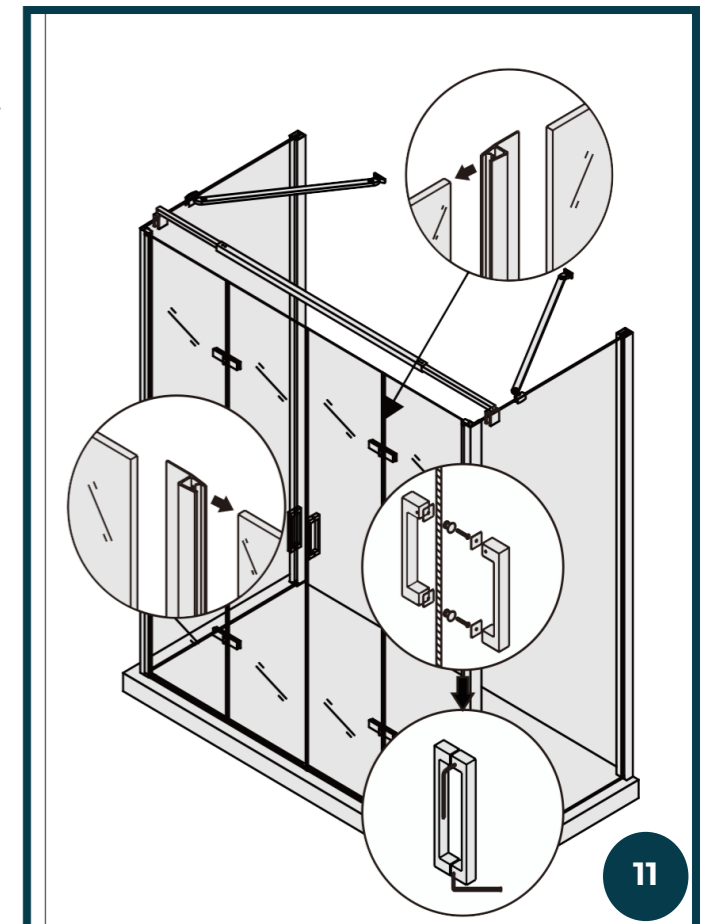

12. SCHRITT

1. Legen Sie die oberen Abdeckkappen der Wandprofile auf die festen Wände
2. Dichten Sie die Ränder der Duschkabine mit Silikon ab.

Hinweis:
das Wandprofil der aufklappbaren Flügel-
tür und das Eckprofil haben keine oberen Ab-
deckblenden.

