

# FAR TOOLS



## NETUP 30PB

Professional Machine



- FR** Aspirateur à décolmatage (Notice originale)
- EN** Decluttering vacuum cleaner (Original manual translation)
- DE** Decluttering Staubsauger (Übersetzung aus dem Original-Anleitung)
- ES** Aspiradora desordenada (Traducción del manual de instrucciones original)
- IT** Aspirapolvere di decluttering (Traduzione dell'avvertenza originale)
- PT** Aspirador decluttering (Tradução do livro de instruções original)
- NL** Ophelderende stofzuiger (Vertaling van de originele instructies)
- EL** Ηλεκτρική σκούπα απολύμανσης (Μετάφραση από τις πρωτυπες οδηγίες)
- PL** Odkurzacz do odpryskania (Tłumaczenie z oryginalnej instrukcji)
- FI** Decluttering pölyn imuri (Käännös alkuperäisestä ohjeet)
- SV** Decluttering vysávač (Översättning från originalinstruktioner)
- BG** Прахосмукачка с дефлуинг (Превод на оригиналната инструкция)
- DA** Declurende støvsuger (Oversættelse fra oprindelige brugsanvisning)
- RO** Aspirator de decluttering (Traducere din instrucțiunile originale)
- RU** Захламление пылесоса (Перевод с оригинальной инструкции)
- TR** Decluttering elektrikli süpürge (Orijinal talimatlar çeviri)
- CZ** Decltající vysavač (Překlad z originálního návodu)
- SK** Decluttering vysávač (Preklad z originálneho návodu)
- HE** זמן טעינה (שואב אבק התזה)
- AR** (تعليمات العمل من قدم برتل) قى ابركه قسنكم
- HU** Decluttering porszívó (Fordítás az eredeti utasítások)
- SL** Decluttering sesalnik (Prevod iz izvirnih navodil)
- EE** Vaakum tolmuimeja (Tõlge originaal juhiseid)
- LV** Pramoninis plaunamas dulkiu siurblys (Tulkojumā no instrukcijas oriģinālvalodā)
- LT** Vaakum tolmuimeja (Vertimas iš originalių instrukcijas)
- HR** Usisni usisavač (Prijevod prema originalne upute)

© FAR GROUP EUROPE

101211-3-J-20250121

[fartools.com](http://fartools.com)



2 min

MERCI !

**ECO  
ACTION**



**100 %  
RECYCLABLE**

Retravailler le conditionnement nous à permis de supprimer tous les emballages issus de produits dérivés d'hydrocarbures, au profit d'un packaging **100 % recyclable**.

>>> Pour en savoir plus, flashez ce code  
et retrouvez toutes les informations sur notre site :





FIG. A



Réf : 101829



13

Réf : 101834

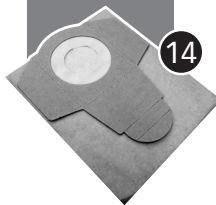

14



02  
2,5 m



12



05



06



07



09



08



11



02

01

03

04



10

X 2





- Ne pas aspirer de farine avec cet appareil
- Do not vacuum flour with this machine
- Kein Mehl mit diesem Gerät absaugen
- No se puede aspirar harina con este aparato
- Non aspirare della farina con questo apparecchio
- Não aspirar farinha com este aparelho
- Gebruik dit toestel niet om meel op te zuigen
- Μην αναρροφάτε άλευρα με την συσκευή αυτή
- Nie wdychać pyłów
- Älä ime jauhoja tällä laitteella
- Sug inte upp mjöl med den här apparaten
- Не събирайте брашно с тази машина
- Sug ikke mel op med dette apparat
- Nu aspirați făină cu acest aparat
- Запрещается использовать устройство для всасывания металлических опилок
- Bu cihazı kullanırken toz yutmayın
- S přístrojem neodsávejte mouku
- Týmto prístrojom nenasávajte múku
- אין לבצע שאיבת קמח באמצעות מכשיר זה
- لا تشفط الطحين بهذا الجهاز
- Ne szívjon fel lisztet a készülékkel
- S to napravo ne vsesavajte moka
- Tolmu mitte sisse hingata
- Su šiuo aparatu neįkvėpti dulkių
- Neieelpot ar šo ierīci putekļus
- Nemojte usisati brašno s ovim uređajem

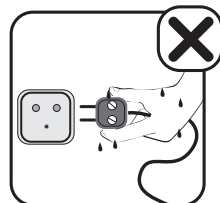
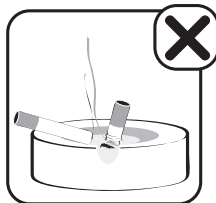
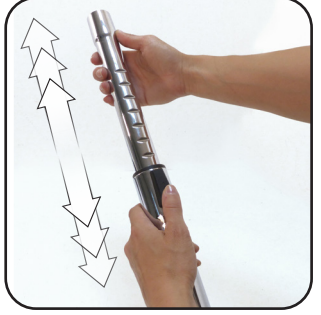
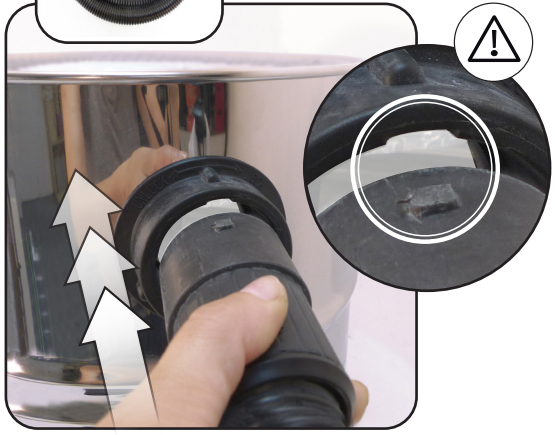
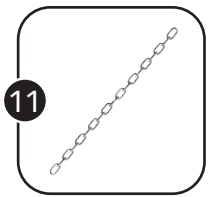
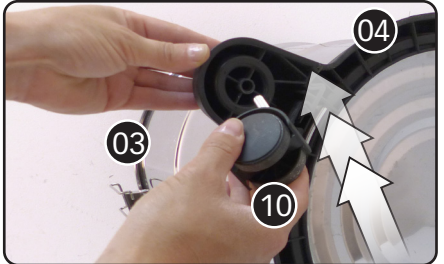
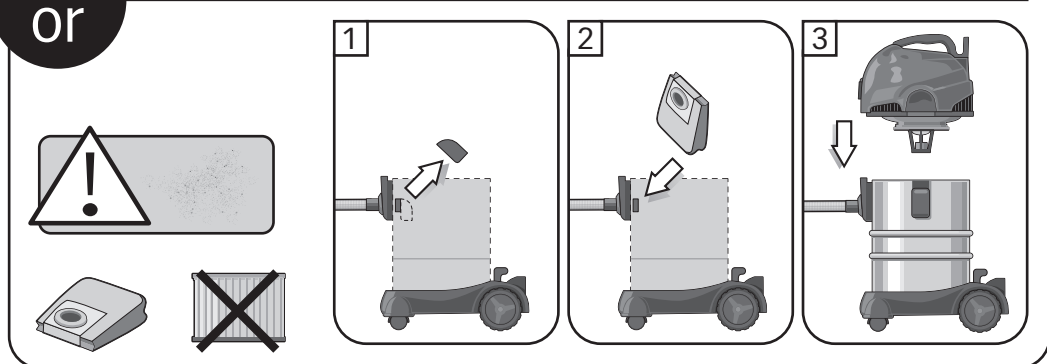
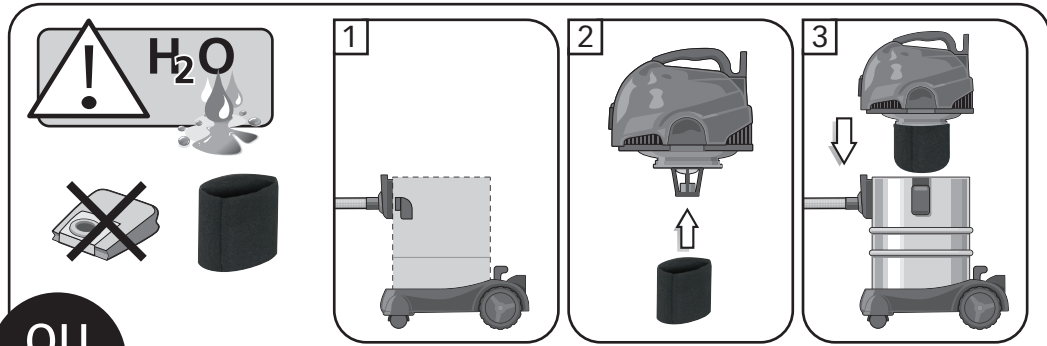
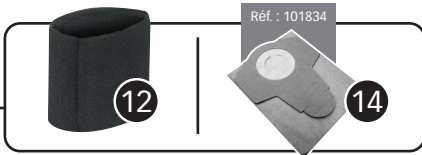
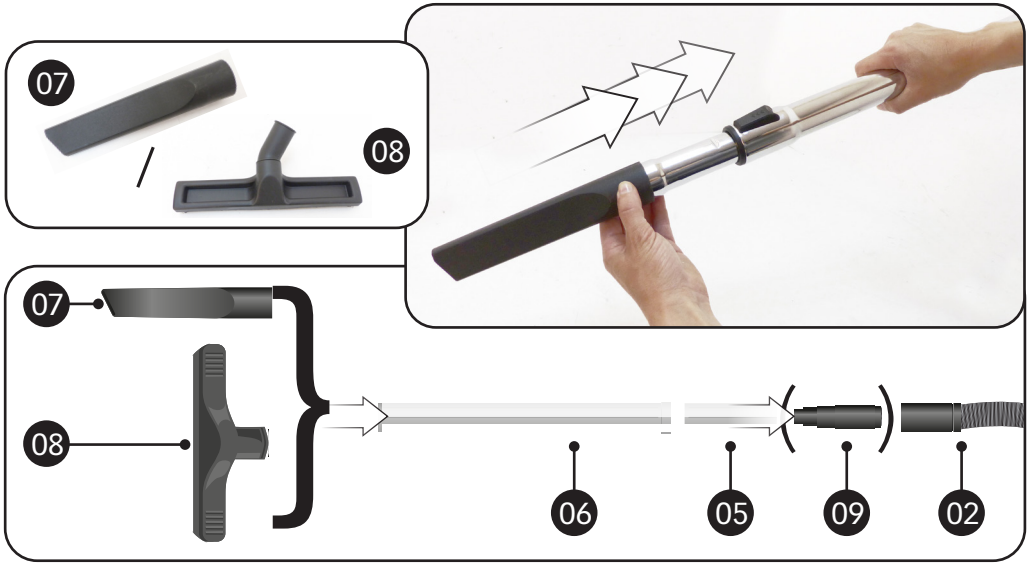



FIG. B







Ref. : 101829



13



ou  
or

Ref. : 101834

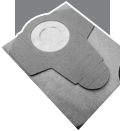

14

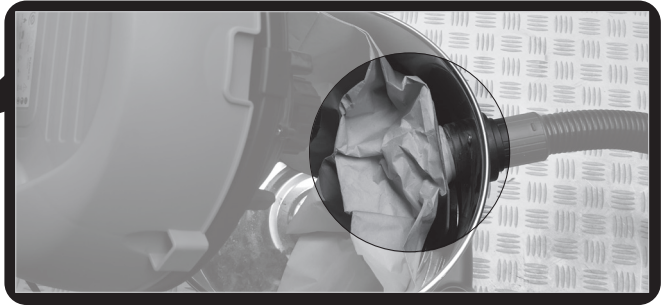
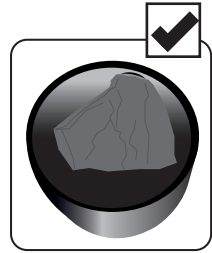

01

03



CLIC !

x 2

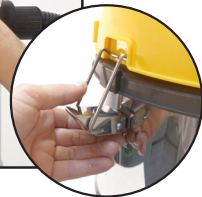
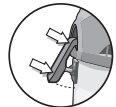

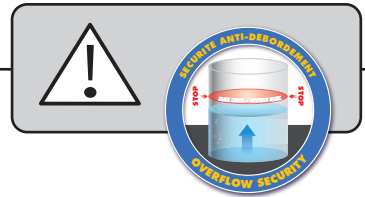

- (A) Bouchon flotteur  
Vlotter stopper  
Float stopper  
Tapón del flotador  
Float rolha  
Float stopper
- (B) Entrée d'air - accès au filtre  
Luchtinlaat - toegang filter  
Entrada de aire - acceso al filtro  
Entrada de ar - de acesso ao filtro  
Air inlet - filter access

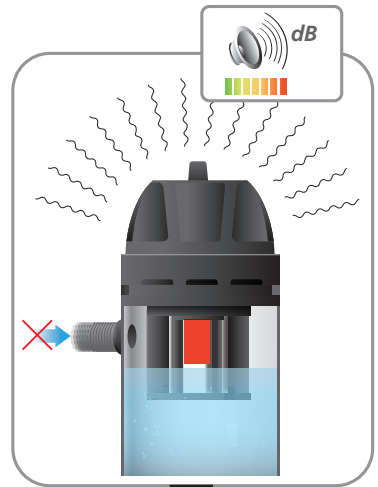
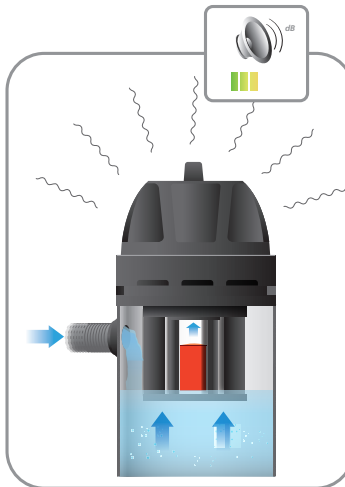
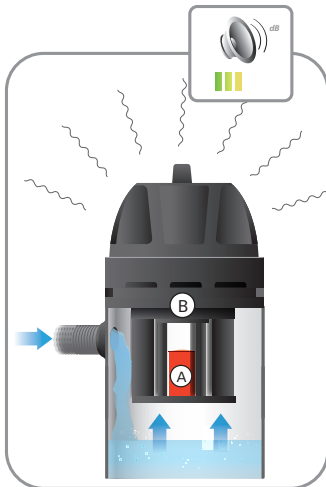

Attention ! lorsque le flotteur atteint le haut, le bruit du moteur augmente fortement mais celui-ci ne s'arrête pas !  
Il est recommandé de stopper l'aspirateur immédiatement et de procéder à la vidange de la cuve !

Kijk Uit! wanneer de vlotter voor de top bereikt, motorgeluid sterk toeneemt, maar dit houdt niet op!  
Het wordt aanbevolen om onmiddellijk te stoppen stofzuigen en ga verder met de tank af te tappen!

Cuidado! cuando el flotador llega a la cima, el ruido del motor aumenta bruscamente, pero esto no se detiene! Se recomienda dejar pasar la aspiradora inmediatamente y proceder a drenar el tanque!

Cuidado! quando o flutuador atinge o topo, o ruído do motor aumenta acentuadamente, mas isso não para! Recomenda-se a interromper a aspiração imediatamente e prosseguir para drenar o tanque!

Attento! quando il galleggiante raggiunge la parte superiore, il rumore del motore aumenta bruscamente, ma questo non si ferma! Si raccomanda di interrompere l'aspirazione immediatamente e procedere svuotare il serbatoio!

Watch Out! when the float reaches the top, engine noise increases sharply but this does not stop! It is recommended to stop vacuuming immediately and proceed to drain the tank!

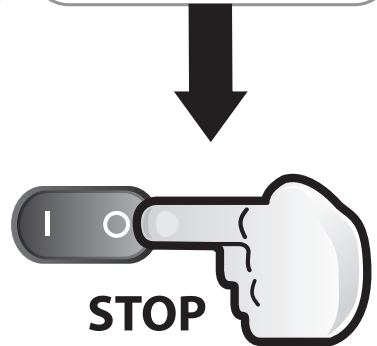



FIG. D

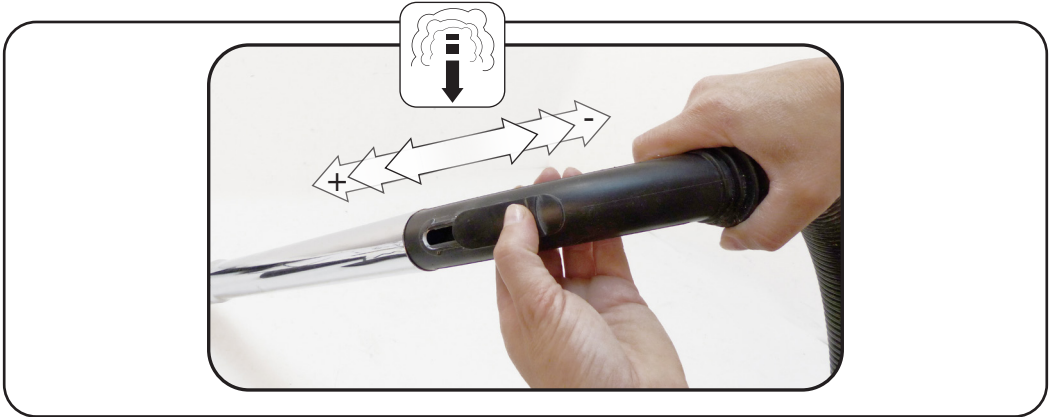
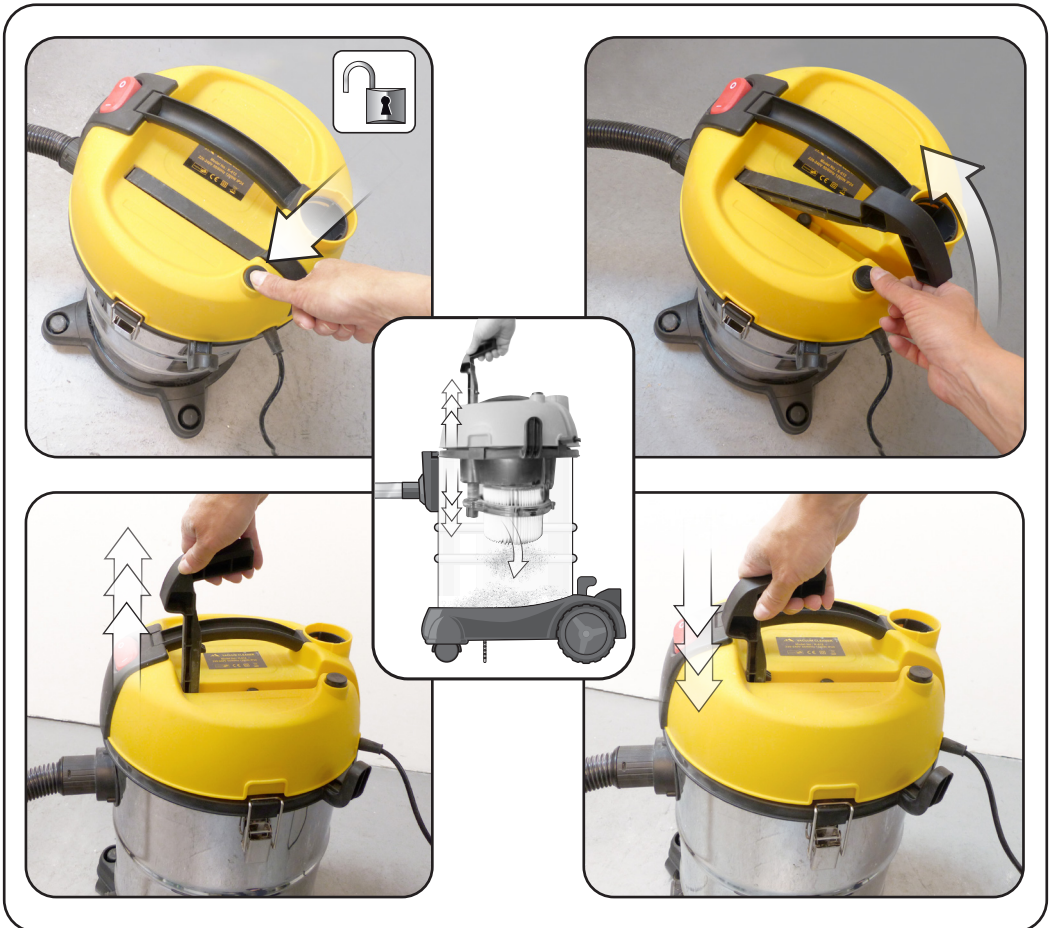
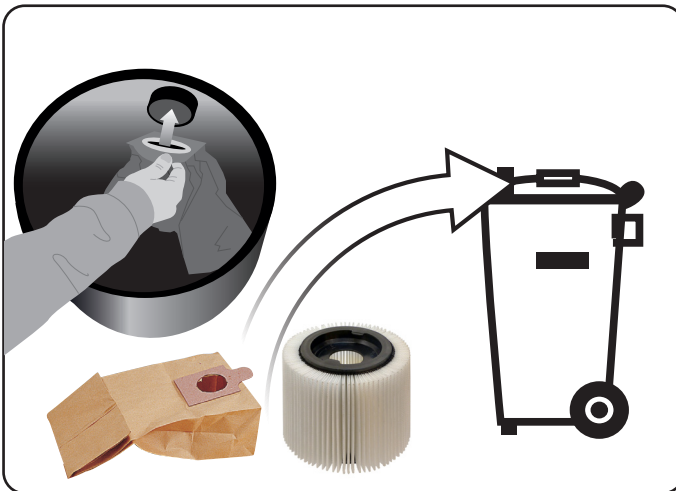
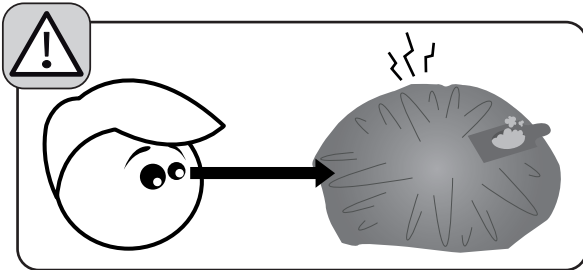
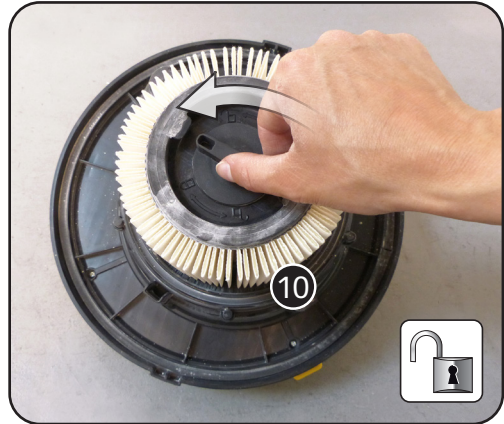
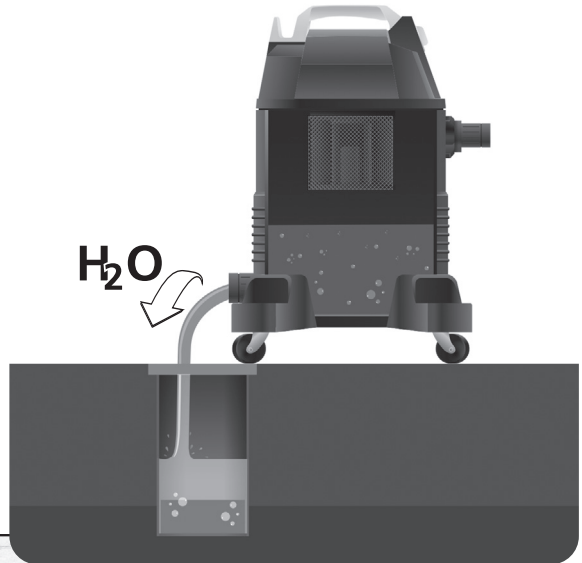
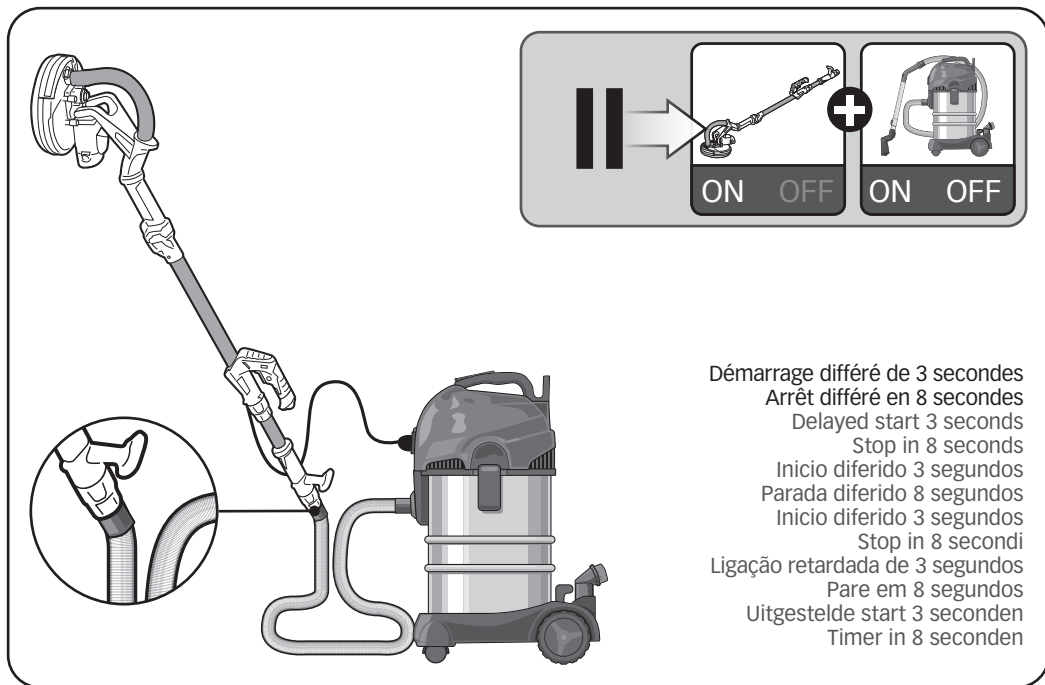

FIG. E









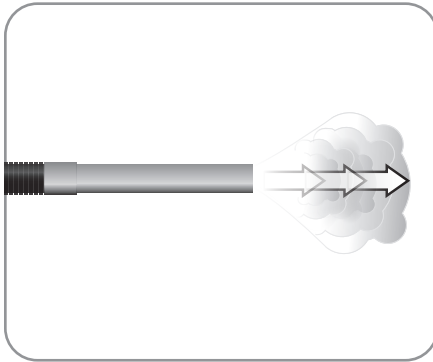



Lire les instructions avant usage :  
 Read the instructions before use :  
 Vor Einsatz des Geräts Anweisung lesen :  
 Léase las instrucciones antes de usar :  
 Leggere le istruzioni prima dell'uso :  
 Ler as instruções antes da utilização :  
 Lees voor het gebruik de instructies :  
 ΔΙΑΒΑΣΤΕ ΤΙΣ ΟΔΗΓΙΕΣ ΠΡΙΝ ΑΠΟ ΤΗ ΧΡΗΣΗ:  
 Zapoznać się instrukcją przed użyciem :  
 Lue ohjeet ennen käyttöä :  
 Läs anvisningarna före användning :  
 læs instruktionerne før brug  
 Înainte de utilizare, cititi instructiunile :

Внимательно прочитайте следующие инструкции :  
 Kullanimadan talimatları okuyunuz :  
 Pozorně si přečtete následující pokyny :  
 Pred použitím si prečítajte pokyny :  
 Les bruksanvisningen før bruk:  
 اقرأ التعليمات قبل الاستخدام.  
 használat előtt olvassuk el az utasítást :  
 Pred uporabo preberite ustrezna navodila  
 Прочетете указанията за употреба :  
 Enne kasutamist lugege instruksiooni  
 Prieš naudojimą perskaityti instrukciją  
 izlasīt instrukcijas pirms lietošanas  
 Pročitati upute prije uporabe:

×





	<p>Tension et fréquence assignée: Nominal frequency and power: Nennspannung und Nennfrequenz : Tensión y frecuencia fijada: Tensione e frequenza assegnata: Tensão e frequência fixa: Aangewezen spanning en frequentie: ΟΝΟΜΑΣΤΙΚΗ ΤΑΣΗ ΚΑΙ ΣΥΧΝΟΤΗΤΑ: Napięcie i częstotliwość przydzielona: Jännite ja määrätty taajuus: Angiven spänning och frekvens: Anført spænding og frekvens: Tensiune și frecvență de lucru:</p>	<p>Заданное напряжение и частота: Tahsis gerilimi ve frekans: Stanovené napětí a frekvence: Stanovené napätie a frekvencia: Merkespenning og merkefrekvens: الفصلطية والذبيذنية الجبرمجة. Névleges feszültség és frekvencia: Napetost in določena frekvenca: Консумирано напрежение и честота : Määratud plinge ja sagedus Nustatyta įtampa ir dažnis Noteiktais spriegums un frekvence. Napon i nazivna frekvencija:</p>	230 V ~ 50 Hz
-----------------------------------------------------------------------------------	-----------------------------------------------------------------------------------------------------------------------------------------------------------------------------------------------------------------------------------------------------------------------------------------------------------------------------------------------------------------------------------------------------------------------------------------------------------------------------	---------------------------------------------------------------------------------------------------------------------------------------------------------------------------------------------------------------------------------------------------------------------------------------------------------------------------------------------------------------------------------------------------------------------------------------------------------------------------	---------------

	<p>Puissance assignée: Nominal power: Nennleistung: Potencia fijada: Potenza assegnata: Potência assinada: Onbelast toerental: ΟΝΟΜΑΣΤΙΚΗ ΙΣΧΥΣ: Prędkość na biegu jałowym: Teho: Angiven effekt: Anført styrke: Putere de lucru:</p>	<p>Заданная мощность: Tahsis edilen güç: Stanovený příkon: Predpísaný výkon: Merkeeffekt: القدرة الجبرمجة. Névleges teljesítmény : Določena jakost: Консумирана мощность: Määratud võimsus. Nustatyta galia Noteiktā jauda Nazivna snaga:</p>	1200 W
-----------------------------------------------------------------------------------	---------------------------------------------------------------------------------------------------------------------------------------------------------------------------------------------------------------------------------------------------------------------------------------	-----------------------------------------------------------------------------------------------------------------------------------------------------------------------------------------------------------------------------------------------------------------------------------------------	--------

	<p>Poids : Weight : Gewicht : Peso : Peso : Peso : Gewicht : ΒΑΡΟΣ : Masa : Paino : Vikt : Vægt : Greutate :</p>	<p>Bec : Ağırlık : Hmotnost : Hmotnosť : Vekt: العوزن. Súly : Teža : Терло : Raskus Svoris Svars Težina</p>	6,5 kg
-----------------------------------------------------------------------------------	------------------------------------------------------------------------------------------------------------------------------------------------------------------	-------------------------------------------------------------------------------------------------------------------------------------------------------------	--------

		16 kPa - 108 m³/h
-------------------------------------------------------------------------------------	--	-------------------

	<p>Conformité européenne Conforms to EC standards : CE-Konformität : Cumple con las directivas CE : Conforme alle norme CE : Conforme às normas CE : Voldoet aan de EG-normen : Ευρωπαϊκή Συμμόρφωση Zgodność z normami CE : EU-standardien mukainen : EU-standardien mukainen : Overholder EU standarderne : Conform cu normele europene:</p>	<p>соответствие европейским стандартам: Avrupa uygunluk : evropská shoda : európska dohoda : Europeisk konformitet مطابق للخواصفات الأوروبية. evropska ustreznost : európai megfeleléség : Съответствие с европейските норми : Euroopa Liidu vastavusmärk Europinių normų atitikima Atbilstība Eiropas standartiem Evropska sukladnost</p>	X
-------------------------------------------------------------------------------------	------------------------------------------------------------------------------------------------------------------------------------------------------------------------------------------------------------------------------------------------------------------------------------------------------------------------------------------------------------------------------------------------	--------------------------------------------------------------------------------------------------------------------------------------------------------------------------------------------------------------------------------------------------------------------------------------------------------------------------------------------------------------------------------------------	---





	Capacité cuve :	beholderkapacitet :	30 L
	Tank capacity:	capacitate cuvă:	
	Volumen der Wanne :	объем бака :	
	Capacidad depósito :	Кap Kapasitesi :	
	Capacità vasca :	kapacita nádoby :	
	Capacidade da tina :	obsah nádrže :	
	Capaciteit van de kuip :	מדידת מים :	
	χωρητικότητα δεξαμενή :	سعة الخزان :	
	Pojemność zbiornika :	a kád kapacitása :	
	Säiliön vetävyys :	kapaciteta kadi :	
Cisternkapacitet :	Капацитет на корпуса :		

	Diamètre tuyau :	rordiameter :	Ø 35 mm
	Tube diameter :	diametru furtun :	
	Schlauchdurchmesser :	диаметр трубы :	
	Diámetro tubo :	Boru çapı :	
	Diametro tubo :	průměr trubky :	
	Diâmetro do tubo :	priemer hadice :	
	Diameter van de buis :	קוטר צינור :	
	Διάμετρο σωλήνα :	قطر الأنبوب :	
	Srednica przewodu :	a cső átmérője :	
	Putken halkaisija :	premer cevi :	
Rördiameter :	Диаметър на тръбата :		

	Soumis à recyclage	Подлежит переработке	X
	Subjected to recycling	Atmayıniz :	
	Sujeto a reciclaje	Nevyhazujte je do bežného odpadu :	
	Sottoposti a riciclaggio	Neodhadzovat :	
	Sujeitos à reciclagem	Gjenvinningspliktig	
	Não deite no lixo :	فلا ترمدها هكذا فهي القمامة.	
	Niet wegwerpen :	ne mečíte!	
	Υπόκειται σε ανακύκλωση	Ne odvržite ga/jih vstran :	
	Nie wyrzucac :	Taaskasutusse kuuluv	
	Älä heitä pois luontoon :	Ärge visake seda minema :	
Batteriet får inte kastas :	Nemetykíte :		
Bortkast det ikke :	Nemest :		
Nu le auncati :	Podvrgnuto recikliranju		

#### Recyclage des déchets :

Les outils, accessoires et leur emballages doivent suivre une voie de recyclage adaptée. Conformément aux directives Européenne 2012/19/UE et 2006/66/CE, les composants d'un produit doivent être séparés, collectés, recyclés ou éliminés en conformité avec les réglementations environnementales en vigueur. Les appareils, batteries, piles, huiles, emballages devront être déposés dans les systèmes d'élimination des déchets spéciaux tels que déchetteries. Renseignez-vous auprès de votre commune pour connaître l'organisme le plus proche à même de retraiter ou de collecter ces déchets.

	Recyclable, soumis au tri sélectif	Reciclabile sub rezerva reciclare	X
	Recyclable, subject to recycling	Повторно упаковка подлежит вторичной переработке	
	Recyclingfähige, unterliegen Recycling	Gerí dönüştürme Geri dönüştürülebilir ambalaj konusu	
	Recyclables, sujetos a reciclaje	Recyklovateľné podléhajúci recyklácii	
	Riciclabili, soggetti a riciclaggio	Recyklovateľné podliehajúce recyklácii	
	Recicláveis, sujeitos à reciclagem	Resirkulerbar, med förbehold om selektiv sortering	
	Recycleerbare, onderworpen aan recycling	رودبئلا نا يرال بئربئب رودبئلا نا يرال تابازئلا فئول بئئلا و بئب بئلا	
	ΑΝΑΚΥΚΛΩΣΙΜΟ, ΥΠΟΚΕΙΤΑΙ ΣΕ ΕΠΙΛΕΚΤΙΚΗ ΔΙΑΛΟΓΗ	Újrahasznosítható csomagolás alá újrahasznosítás	
	Opakowanie nadaje się do recyklingu podlegają recyklingu	Reciklirati predmet recikliranje	
	Kierrätettävien pakkausten kohteena kierrätys	Pakendite suhtes ringlussevõtu	
Återvinningsbara förpackningar omfattas återvinning	Pärstrådājams iepakojums otrreizējai pārstrādei		
Рециклираци се опаковки подлежат на рециклиране	Perdirbamų taikomos perdirbimo		
Genanvendelig underlagt genbrug	Može se reciklirati, podložno selektivnom sortiranju		

<b>IP 24</b>		X
--------------	--	---







NETUP 30PB

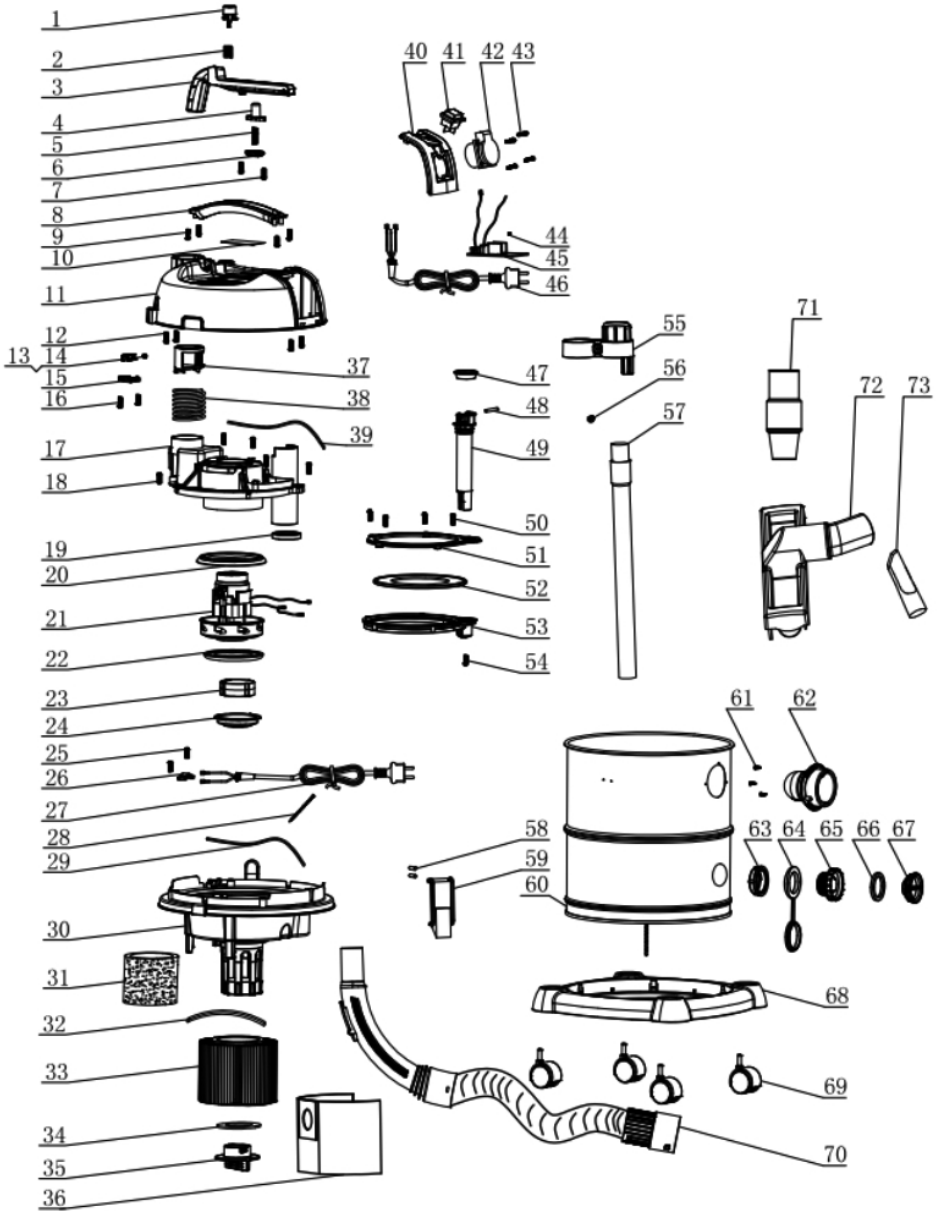



**FAR TOOLS** NETUP 30PB  
101211

230V-50Hz 1200 W 16 Kpa IP24

Puissance totale : **3200 W**. Puissance Maximum asservie : **2000 W**

FAR GROUP EUROPE - 192, Avenue Yves Farge - 37700 St. Pierre-des-Corps - FRANCE

K-612D/G200

Serial number / numéro série :

Made in P.R.C.

**MAX: 2000W**

**FAR TOOLS**



DECLARATION DE CONFORMITE  
VERKLARING VAN OVEREENSTEMMING  
DECLARACION DE CONFORMIDAD  
DICHIARAZIONE DI CONFORMITA  
KONFORMITÄSERKLÄRUNG  
DECLARATION CONFORMITY  
DECLARAÇÃO DE CONFORMIDADE  
DECLARACJA ZGODNOSCI Z NORMAMI  
OM ÖVERENSSTÄMMELSE  
VAATIMUSTENMUKAISUUSVAKUUTUS  
OVERENSSTEMMESESERKLÆRING  
ΔΗΛΩΣΗ ΣΥΜΜΟΡΦΩΣΗΣ

DECLARAȚIE DE CONFORMITATE  
VYHLÁSENIE ZHODY  
Декларация соответствия  
SAMSVARERKLÆRING  
Uygunluk beyanı  
التصريح بالمتطابق ة  
PROHLÁŠENÍ SHODY  
EGYZŐSÉGI NYILATKOZAT  
Декларация за съответствие с нормите  
IZJAVA O SKLADNOSTI  
DECLARACIJA  
ATTIKTIES DECLARACIJA  
KINNITUS  
IZJAVA O SUKLADNOSTI

Le soussigné,  
Ondergetekende,  
Der Unterzeichner,  
O abaixo assinado,  
Undertecknad,  
Долуподписаният  
Undertegnede  
Subsemnatul,  
Я, нижеподписавшийся,  
Imzalayan,  
Niže podepsany,  
Toliau pasirašęs

Declare par la présente que,  
Verklaart hiermede dat,  
Erklärt hiermit daß,  
Declara pela presente que,  
Förklarar härmed att  
Заявява с настоящото  
erklærer hermed, at  
Declar prin prezenta că,  
настоящим подтверждаю, что  
Mevcut belgeyle beyan ediliyor ki,  
tımto prohlasuje, že,  
Pareiskia, kad,

Personne autorisée à constituer  
le dossier technique :  
Christophe HUREL



FAR GROUP EUROPE  
192, Avenue Yves Farge  
37700 St. Pierre-des-Corps  
FRANCE

El suscrito,  
Il sottoscritto,  
The undersigned,  
Ninej podpisany  
Allekirjoittanut,  
Ο ΚΑΤΩΘΙ ΥΠΟΓΡΑΦΜΕΝΟΣ,  
Nizšie podpisany  
Undertegnede,  
الموقّع أدناه  
Alulírott,  
Podpisani,  
Apakšā parakstījies  
allakirjutanu  
Dolje potpisani,

Declaro por la presente, que,  
Dichiare che,  
Declares that,  
OoWiadcza niniejszym, że  
Ilmoittaan täten että,  
ΔΙΑ ΤΟΥ ΠΑΡΟΝΤΟΣ ΔΗΛΩΝΕΙ ΟΤΙ,  
týmto vyhlasuje, že  
Erklærer herved at,  
يصرح استنادا على ذلك  
kijeleltem, hogy a Készülék Izjavlja da,  
Pareiskia, kad,  
Ar šo apliecinā, ka,  
Kinnitab, et  
izjavljuje u ovom dokumentu da je

Aspirateur à décolmatage / Decluttering vacuum cleaner / Decluttering Staubsauger / Aspiradora desordenada /  
Aspirarpolvare di decluttering / Aspirador decluttering / Öphelderende stofzuiger / Ηλεκτρική οκούλα απολύμανσης / Odurzacz do odpryskania /  
Decluttering pölyn imuri / Decluttering vysavač / Прахосмуканка с дефлуинг / Declurende støvsuger / Aspirator de decluttering / Закламлине пылесоса /  
Decluttering elektrikli süpürge / Declajici vysavač / Decluttering vysavač / סוגב אבר תודה / מכשף כירמנית / Decluttering porszivo / Decluttering sesalnik /  
Vaakum tolmuimeja / Pramoninis plaunamas dulkių siurblys / Vaakum tolmuimeja / Usisni usisvac

## code

FARTOOLS / 101211 / NETUP 30PB / K-612D/3200

**Est conforme et satisfait aux directives et normes CE,**  
In overeenstemming is met en Voldoet aan EG richtlijnen,  
Den folgenden EU-Bestimmungen entspricht,  
Respeita e está em conformidade com as normas CE,  
Överensstämmer med och uppfyller EG-standarder,  
Съответства и отговаря европейските норми  
Er i overensstemmelse med og overholder EU standarderne  
Este conform și satisfacă normele CE  
полностью соответствует и удовлетворяет  
требованиям стандартов ЕС  
CE şartlara uygundur,  
odpovídá normám ES.  
Atitinka ir atitinka EB direktyvas ir standartus,

Cumple con la directivas de la CE,  
E conforme alle direttive CEE,  
Complies with the EEC directives and standards,  
Odpowiada normom UE,  
Täyttää EU-vaatimukset,  
ΣΥΜΜΟΡΦΩΝΕΤΑΙ ΚΑΙ ΙΚΑΝΟΠΟΙΕΙ ΤΙΣ ΟΔΗΓΙΕΣ ΚΑΙ ΤΑ ΠΡΟΤΥΠΑ CE,  
zodpovedá normám ES.  
Samsvarer med og tilfredsstiller CE-direktiver og standarder,  
بأن الجهاز يتطابق و يلبى م عايير مموعة الدول الأوروبية  
kijelegti a CE szabványok előírásait.  
Je v skladu z in izpolnjuje norme Evropske skupnosti.  
Atbilst un atbilst EK direktīvas un standartus.  
Vastab ja vastab EU direktīviudele ja standarditele,  
Sukladan i ispunjava direktive i standarde CE,

2014/30/EU 2014/35/EU 2011/65/EU 2015/863/EU

EN IEC 55014-1:2021  
EN IEC 55014-2:2021  
EN IEC 61000-3-2:2019+A1:2021  
EN 61000-3-3:2013+A1:2019+A2:2021  
EN 62233:2008  
EN 60335-2-2:2010+A11:12+A1:13  
EN 60235-1:2012+A11:2014+A13:2017+A1:2019+A14:2019+A2:2019+A15:2021

Christophe HUREL,  
Président Directeur Général  
02/06/2023  
Fait à St. Pierre-des-Corps

## GARANTIE - WARRANTY

# 2 ANS GARANTIE

### FR. GARANTIE

Cet outil est garanti contractuellement contre tout vice de construction et de matière, à compter de la date de vente à l'utilisateur et sur simple présentation du ticket de caisse. La garantie consiste à remplacer les parties défectueuses. Cette garantie n'est pas applicable en cas d'exploitation non conforme aux normes de l'appareil, ni en cas de dommages causés par des interventions non autorisées ou par négligence de la part de l'acheteur. La garantie ne s'applique pas sur les dommages causés par une défaillance de l'outil.

### DE. GARANTIE

Die Garanzzeit für dieses Gerät in Bezug auf Konstruktions- und Materialfehler beträgt lt. Vertrag bei Vorlage des Kassabons. Die Garantieleistung besteht im Ersatz schadhafter Teile. Die Garantie erlischt bei einem Einsatz des Geräts, der nicht normentsprechend ist, bei Schäden, die auf unsachgemäße Eingriffe zurückzuführen sind bzw. bei Nachlässigkeit seitens des Käufers. Die Garantie erstreckt sich nicht auf Schäden, die auf Fehlfunktionen des Geräts zurückzuführen sind.

### IT. GARANZIA

Quest' attrezzo è garantito per contratto contro qualsiasi difetto di costruzione e di materia, a partire dalla data di vendita all'utente e su semplice presentazione dello scontrino. La garanzia consiste nel sostituire le parti difettose. Questa garanzia non è applicabile in caso di sfruttamento non conforme alle norme dell'apparecchio, né in caso di danni causati da interventi non autorizzati o da negligenza da parte dell'acquirente. La garanzia non si applica ai danni causati da un'avarità dell'attrezzo.

### EN. GARANTIE

This tool is guaranteed, in writing, against any defect in manufacture of parts from the date of sale, upon simple presentation of the sales slip. The guarantee is limited to the replacement of faulty parts. This guarantee is not applicable in the event of usage which is not conform with the intended usage of the apparatus, nor in the event of damage caused by unauthorised servicing or negligence on behalf of the purchaser. This guarantee does not apply to any damage caused by the failure of this tool.

### ES. GARANTIA

Esta herramienta se garantiza contractualmente contra todo defecto de construcción y materia, a partir de la fecha de venta al usuario y sobre simple presentación del recibo de caja. La garantía consiste en sustituir a las partes defectuosas. Esta garantía no es aplicable en caso de explotación no conforme a las normas del aparato ni en caso de daños causados por intervenciones no autorizadas o por negligencia por parte del comprador. La garantía no se aplica sobre los daños causados por un fallo del herramienta.

### NL. GARANTIE

Dit gereedschap heeft een garantie tegen constructiefouten en materiaaldefecten, die geldig is vanaf de aankoopdatum door de gebruiker, op vertoning van de kassabon. De garantie betreft de vervanging van de defecte onderdelen. Deze garantie is niet van toepassing indien het apparaat niet volgens de normen gebruikt is, noch in geval van schade veroorzaakt door onjuist gebruik of nalatigheid van de koper. De garantie is niet van toepassing op schade voortvloeiend uit een defect van het gereedschap.

### PT. GARANTIA

Esta ferramenta tem uma garantia contratual contra qualquer defeito de construção e de material, a partir da data de venda ao utilizador e sobre simples apresentação do talão da caixa. A garantia consiste em substituir as partes defeituosas. Esta garantia não é aplicável no caso de exploração não conforme as normas do aparelho, nem em caso de danos causados pelas intervenções não autorizadas ou por negligência da parte do comprador. A garantia não se aplica para os danos causados por uma falha da ferramenta.

### EL. ΕΓΓΥΗΣΗ

Αυτό το εργαλείο είναι συμβατικά εγγυημένο για οποιοδήποτε κατασκευαστικό και υλικό ελάττωμα, από την ημερομηνία πώλησης στον χρήστη και με την επίδειξη της απόδειξης πώλησης. Η εγγύηση συνίσταται στην αντικατάσταση των ελαττωματικών εξαρτημάτων. Αυτή η εγγύηση δεν ισχύει σε περίπτωση λειτουργίας που δεν συμμορφώνεται με τα πρότυπα της συσκευής, ούτε σε περίπτωση ζημίας που προκαλείται από μη εξουσιοδοτημένες επεμβάσεις ή αμέλεια εκ μέρους του αγοραστή. Η εγγύηση δεν ισχύει για ζημίες που προκαλούνται από αστοχία εργαλείου.

### PL. GWARANCJA

Narzędzie jest objęte gwarancją na wszelkie wady konstrukcyjne i materiałowe, licząc od daty sprzedaży i użytkownikowi i po okazaniu paragonu kasowego. Gwarancja obejmuje wymianę części wybrakowanych. Gwarancja nie zna-

duje zastosowania w przypadku użytkowania niezgodnego z normami urzędzenia, ani w przypadku szkód spowodowanych działaniami niezgodzonymi lub zaniedbaniami ze strony nabywcy. Gwarancja nie obejmuje szkód powstałych z powodu uszkodzenia urzędzenia.

### SV. GARANTI

Detta verktyg har en avtalsenlig garanti mot konstruktions och materialfel, från och med tidpunkten för användarens inköp och genom uppvisning av kassakvittot. Garantin består i att ersätta de bristfälliga delarna. Denna garanti gäller inte om användningen inte motsvarar apparatens standarder, inte heller vid skador som orsakas av ett tillatna ingrepp eller på grund av köparens vårdslöshet. Garantin gäller inte för skador som orsakats av att verktyget fungerat bristfälligt.

### FI. TAKUUKU

Tämän laitteen takuu on voimassa sopimukseenmukaisesti kattaa kaikki rakenne- ja materiaali- tai lukien ostopäivästä, kassakuittia vastaan. Takuu sisältää viallisten osien korvaamisen. Takuu ei korvaa ohjeiden-vaastaista käyttöä eikä välttämättömien henkilöiden käsittelystä tai ostajan huolimattomuudesta aiheutuneita vahinkoja. Takuu ei vastaa myöskään toimintahäiriöistä aiheutuneita vahinkoja.

### BU. Гаранција

Този инструмент е под договорна гаранция срещу всякакъв дефект в изработката и използваните материали, считано от датата на продажба на потребителя и само срещу представяне на касовата бележка. Гаранционното обслужване се състои в замяна на дефектните части. Настоящата гаранция не е валидна когато апаратът се използва по начин, несъответстващ на стандарта за работа с него, както и в случай на щети, нанесени от неотризирирани лица, или вследствие на проявена небрежност от страна на потребителя. Гаранцията не покрива щети, произтекли вследствие на техническа неизправност на апарата.

### DA. GARANTI

Dette værktøj er dækket af en garantikontrakt for konstruktions- og materialer fejl, som gælder fra købsdatoen ved visning af kassebonen. Garantien består i at udskifte de defekte dele. Garantien dækker ikke fejl opstået som følge af anvendelse, som ikke overholder standarderne for apparatet, eller

## SERVICE APRÈS VENTE - AFTER SALE SERVICE

FARGROUP EUROPE - 192, Avenue Yves Farge - 37700 St. Pierre-des-Corps - FRANCE  
fargroup@fargroup.net

# 2 ANS

## GARANTIE

skader opstået ved ikke autoriserede indgreb eller sløsethed fra brugerens side. Garantien dækker ikke skader opstået, fordi værktøjet har svigtet.

### RO. GARANTIE

Acest aparat este garantat din punct de vedere contractual împotriva tuturor viciilor de construcție și de material, începând de la data vânzării lui către utilizator și la simpla prezentare a bonului de casă. Garanția constă în înlocuirea componentelor defecte. Această garanție nu se aplică în cazul exploatării în alt mod decât cel recomandat de normele aparatului și nici în caz de stricăciuni provocate de intervenții neautorizate sau prin neglijența comparatorului. Garanția nu se aplică asupra pagubelor cauzate de o defectare a aparatului.

### RU. ГАРАНТИЯ

Данное изделие обладает именной, силу контракта гарантией, покрывающей все возможные дефекты изготовления и материала. Гарантия вступает в силу с даты продажи изделия пользователю, для этого достаточно сохранить и предъявить полученные в кассе чек. Гарантия обязывает изготовителя заменить дефектные части изделия. В случае не соответствующего нормам использования изделия, несанкционированного демонтажа или ремонта или небрежного обращения действие гарантии прекращается. Гарантия не покрывает ущерба, возникшего в результате боев в работе изделия.

### TU. GARANTI

Bu arac, satis tarihinden itibaren, kullanıcının sâdece vezne alindisini sunmasıyla tum uretim ve malzeme hatasina karsi garantilidir. Garanti eksik olan kisimlari degistirmek icindir. Bu garanti aracin sartlarina uygun olmayan isleme durumunda, izin verilmeveyen kullanimlardan kaynaklanan, hasarlarda veya alicinin istegi durumunda uygulanmaz. Garanti malzemenin bir eksikliginden meydana gelen bir zararda uygulanmaz.

### CS. ZÁRUKA

Pro tento nástroj platí smluvní záruka na všechny výrobní a materiálové vady od data prodeje uživateli a na základě předložení pokladního bloku. Záruka spočívá ve výměně vadných částí. Tato záruka neplatí v případě použití přístroje, které

neodpovídá normám, ani v případě škod způsobených nepovolenými zásahy nebo nedbalostí ze strany kupujícího. Záruka se nevztahuje na škody způsobené zavádou nástroje.

### SK. ZÁRUKA

Pre tento nástroj platí zmluvná záruka na všetky výrobné a materiálové chyby od dátumu predaja užívateľovi a na základe predloženia pokladničného bloku. Záruka spočíva vo výmene chybných častí. Táto záruka neplatí v prípade použitia prístroja, ktoré nezodpovedá normám, ani v prípade škod spôsobených nepovolenými zásahmi alebo nedbalosťou zo strany kupujúceho. Záruka sa nevztahuje na škody spôsobené poruchou nástroja

### AR. الضمان

في لعتي ءارشلاتقائب ميقتد برجم بلع اعانبو لغتسملا بلا عيبلا خيرات نم اراينعا باءوملا فوع لغتسملا يف بيع نا نم ايدقاعت فومضم قد علا هذه نا تاخاللالت فصرعت ءلا حصف الو بزاهلرا ريباعمل قناتطلما ريع مادختسالا ءلام يف قنبتطل الباق نامضلا اءة نوكي ال ءلطاعلا ءازجالا لادبتس يف نامضلا لئح نم ءتاتلار ررضلا بلع نامضلا قنبتني ال يرتسملا لبق نم لامهلا ءلا يف وا قصخرم ريع لئحت تابلعم نم ءتاتار

### HU. GARANCIA

Erre a szerszámmal szerződéses garanciát vállalunk bármilyen gyártási és anyaghiba felmerülése esetére, a fogyszálto részere történt eladás napjától számítva, a penztári blokk egyszérű felmutatása elleneben. A garancia a hibás alkatrészek cseréjére terjed ki. Ez a garancia nem ervényes, ha a készülék nem rendeltetésszerűen használtak, sem illetéktelen beavatkozások vagy a vásárló hanyagsága okozta károk esetén. A garancia nem fedezi azokat a károkat, melyeket a szerszám hibás működése okozott.

### SI. GARANCIJA

To orodje je z garancijsko pogodbo zašciteno proti vsem napakam v izdelavi in v sestavnem materialu od datuma prodaje naprej in ta velja ob predložitvi blagajniškega računa. Garancija velja za zamenjavo delov z napako. Ta garancija ne velja za uporabo orodja, ki ni v skladu z normami, predpisanimi za omejeno orodje in za primere okvar, ki nastanejo zaradi nedovoljenih posegov na orodju ali zaradi malomarnega rokovanja kupca. Garancija ne velja za škodo, ki jo lahko povzroci okvara orodja.

### ET. GARANTII

See tööriist kuulub lepingu järgi garantiiremonti arvestades alates müümise päevast ja kassatseki alusel kasutajale koigi konstruktsiooni- ja materjalivigade puhul. Garantii seisneb defektsete osade vahetamises. See garantii ei kehti

aparaadi normide ebatavalise eiramise puhul ega ostja poolt keelatud viisil kasutamises või hooletussejätmises tulenevate kahjude korral. Garantii ei kehti seadme defektidest põhjustatud kahjude puhul

### LV. GARANTIJA

Šis prietaisais yra uztikrinamas kaip itin geros kokybes, nuo jo pardavimo datos iki jo panaudojimo, ir jam yra suteikiamas garantinis talonas. Garantijos metu galima pakeisti atsiradusius trumplaiakius gedimus. Si garantija netaikoma esant netinkamam naudojimui ar nesilaikant reikiam šio aparato vartojimo instrukcijų, tai pat pačiam perkeiči jį sugadinus. Garantija taip pat netaikoma, prietaisą naudojant ne pagal paskirtį ir jį apgadinus.

### LT. GARANTIJA

Šim darbarikam ir liguma noteikta garantija visiem defektiem, kas saistās ar konstrukciju un materialu, sākot ar pārdošanas datumu, kad masīnu pardo lietotājam un vienkarši uzradot kases ceku. Garantija iekļauj bojāto daļu nomaiņu. Ši garantija nav derīga, ja aparāts nav lietošs saskaņā ar drošības noteikumiem, ne gādījums ja bojājumi radušies nešankcionētas iejaukšanās gādījuma vai arī piercēja nolaidības dēļ. Garantija nav derīga, ja bojājumi radušies darbarika defekta dēļ

### HR. JAMSTVO

Ovaj alat ima ugovorno jamstvo u slucaju bilo kakvih nedostataka u konstrukciji i materijalu, od datuma prodaje konisniku uz jednostavno predocenje racuna. Jamstvo se sastoji u zamjeni neispravnih dijelova. Ovo se jamstvo ne primjenjuje u slucaju uporabe i eksploatacije koja nije sukladna standardima uređala, niti u slucaju štete uzrokovane neovlaštenim intervencijama ili neomarom kupca. Jamstvo se ne primjenjuje na štetu uzrokovanu nekim nedostatkom alata.

## SERVICE APRÈS VENTE - AFTER SALE SERVICE

FARGROUP EUROPE - 192, Avenue Yves Farge - 37700 St. Pierre-des-Corps - FRANCE  
fargroup@fargroup.net



## FAR GROUP EUROPE

Une société du groupe **SIGMA**

192, Avenue Yves Farge  
37700 St. Pierre-des-Corps  
FRANCE

[fartools.com](http://fartools.com)  
[fargroup@fargroup.net](mailto:fargroup@fargroup.net)

