

Installation Manual

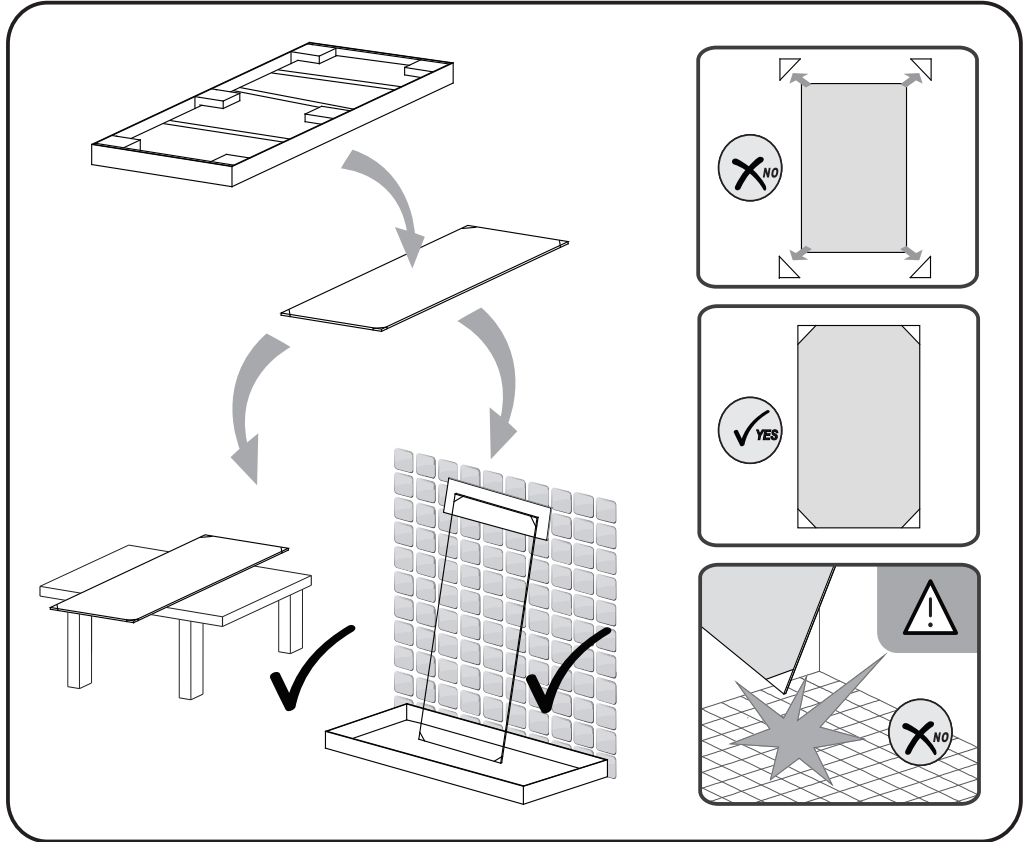

CAUTIONS

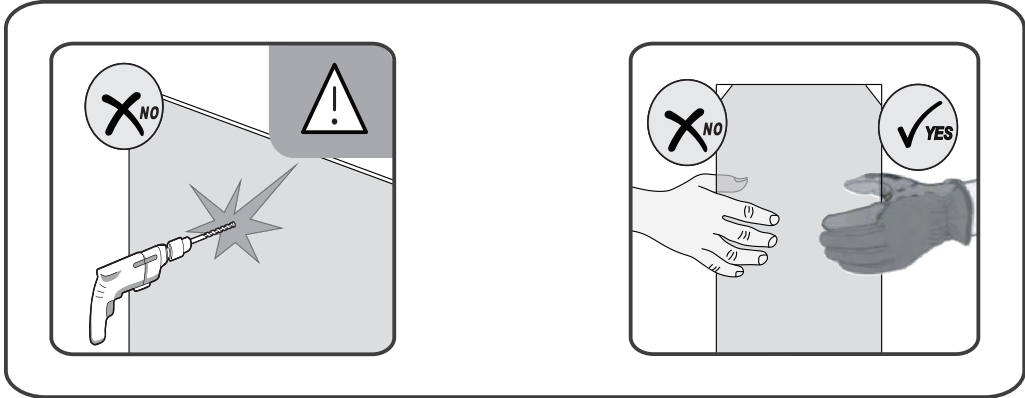



TOOLS REQUIRED

	English	Tape measure
	Deutsch	Maßband
	Français	Mètre ruban
	Italiano	Metro a nastro
	Español	Cinta métrica
Polski	Taśmado mierzenia	

	English	Spirit level
	Deutsch	Wasserwaage
	Français	Niveau à bulle
	Italiano	Livella a bolla
	Español	Nivelador
Polski	Poziomica	

	English	Drill
	Deutsch	Bohrmaschine
	Français	Perceuse
	Italiano	Trapano elettronico
	Español	Taladro
Polski	Wiertarka	

	English	Rubber hammer
	Deutsch	Bummihammer
	Français	Marteau en caoutchouc
	Italiano	Martello di gomma
	Español	Mazo de goma
Polski	Gumowy młotek	

	English	Silicone & gun
	Deutsch	Silikonpistole
	Français	Pistolet à silicone
	Italiano	Pistola di silicone
	Español	Pistola de silicona y silicona
Polski	Silikon I pistolet	





	English	Drill bit
	Deutsch	Bohrer
	Français	Foret
	Italiano	Punta da trapano
	Español	Broca
Polski	Wiertła	

	English	Flat head & cross head screwdriver
	Deutsch	Schraubenzieher
	Français	Tournevis à tête plate & à lame
	Italiano	Cacciavite a testadi piatta e croce
	Español	Destornillador plano y de cruz
Polski	Plaski i krzyżowy śrubokręt	

	English	Pencil
	Deutsch	Bleistift
	Français	Crayon
	Italiano	Matita
	Español	Lápiz
Polski	Ołówek	

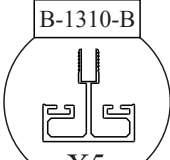
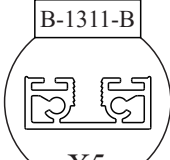
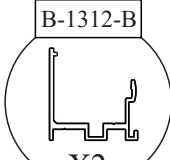
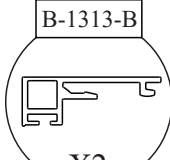
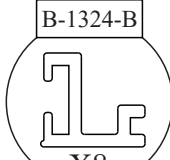
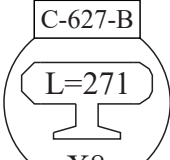
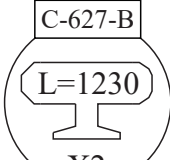
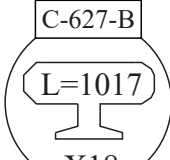
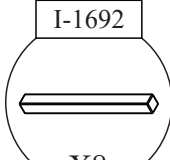
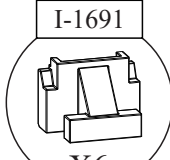
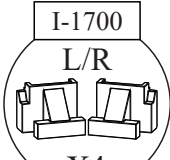
	English	Allen key
	Deutsch	Inbusschlüssel
	Français	Clé Allen
	Italiano	chiave a testa esagonale
	Español	Llave L
Polski	klucz sześciokątny	

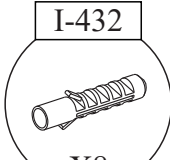
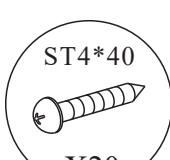
PACKING LIST

 A X5	 B X5	 C X2	 D X2	 E X8
 F X8	 G X2	 H X18	 I X8	 J X6
 K X4	 L X6	 M X8	 N X20	 O X8

PRODUCT SCHEMATIC DIAGRAM

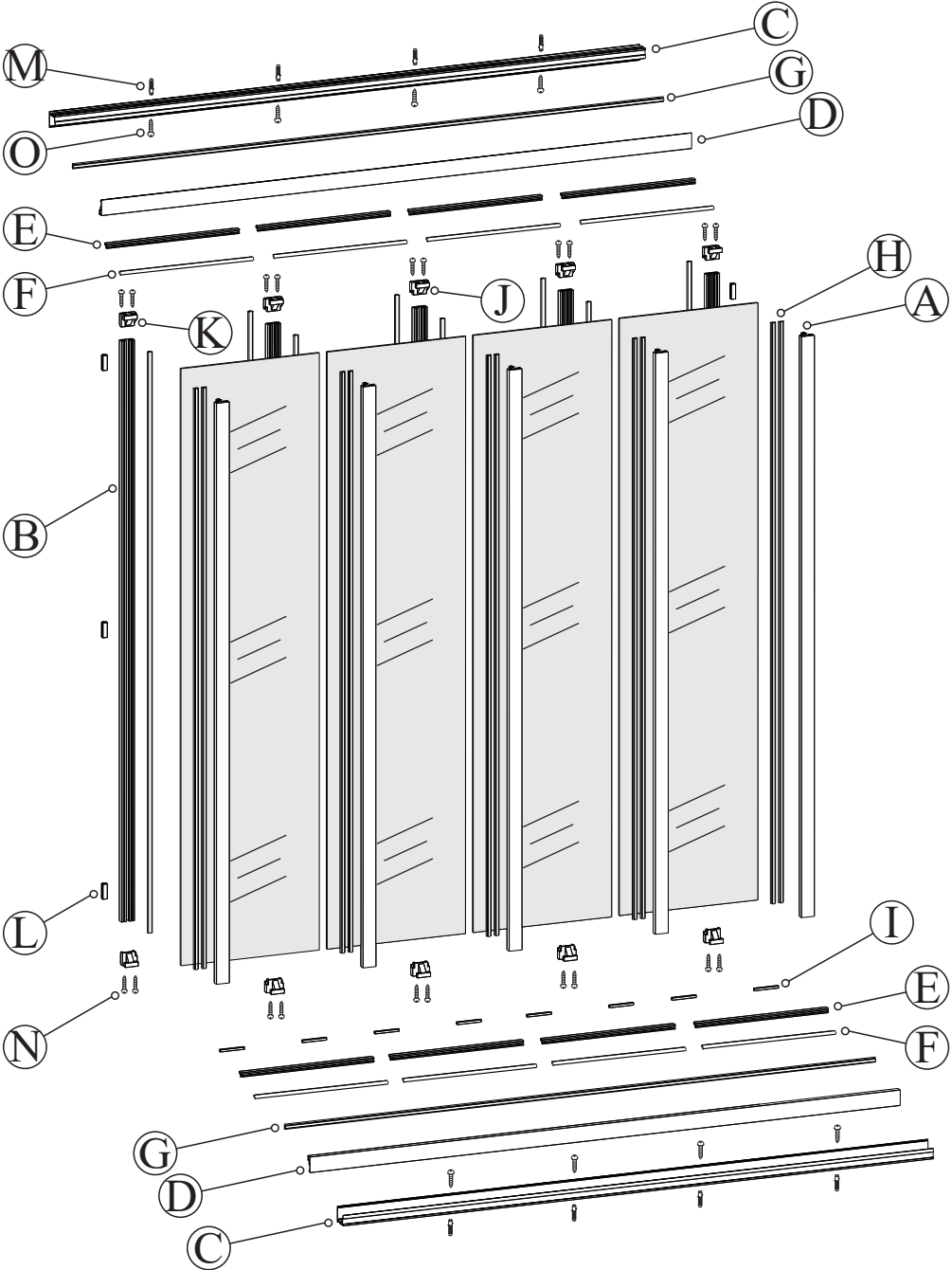

(1)

1

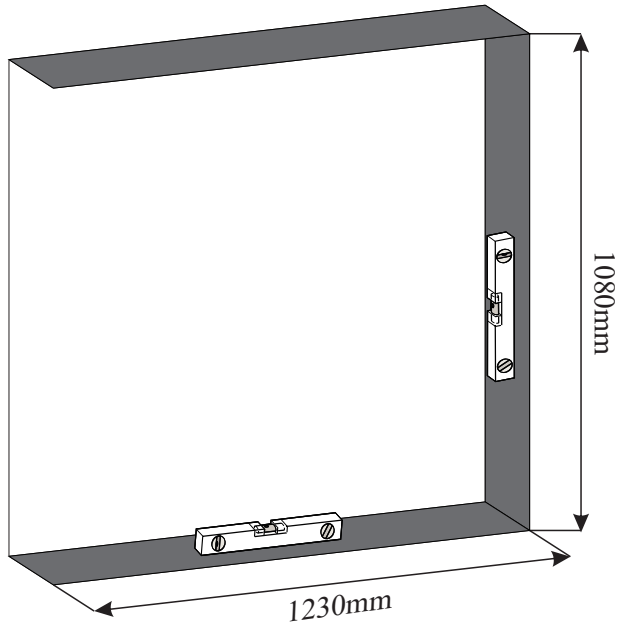

2

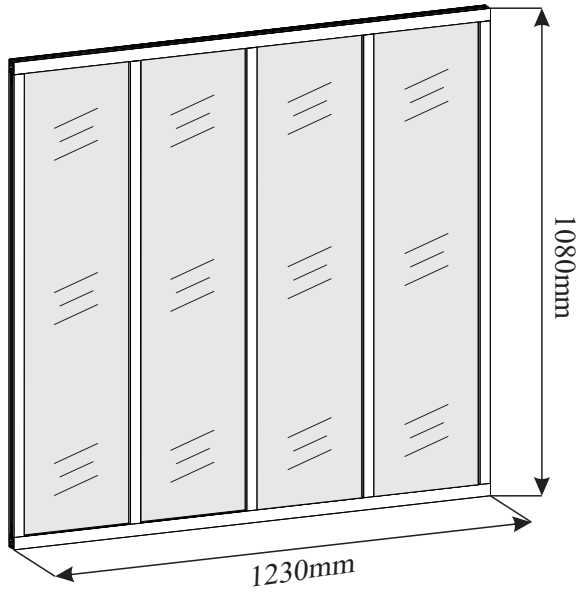

(2)

3

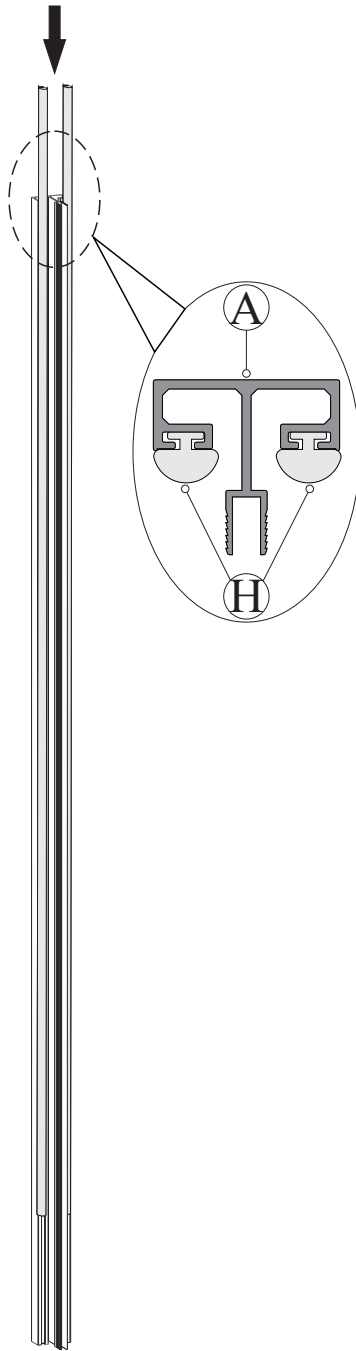

X5

(3)

4

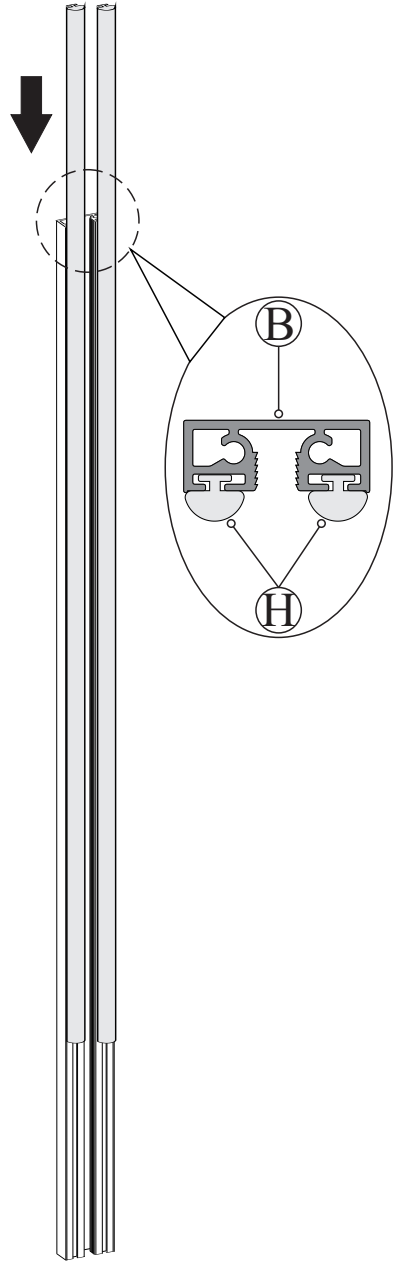
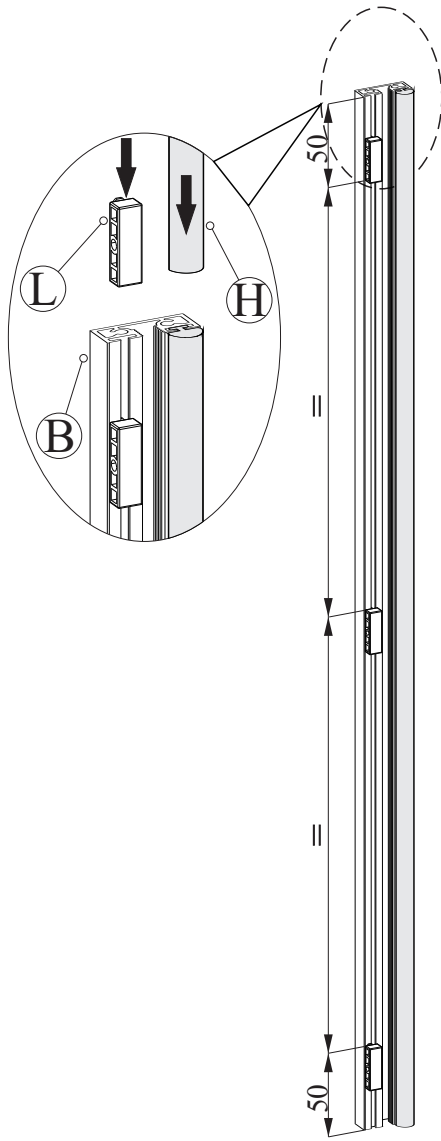

(4)

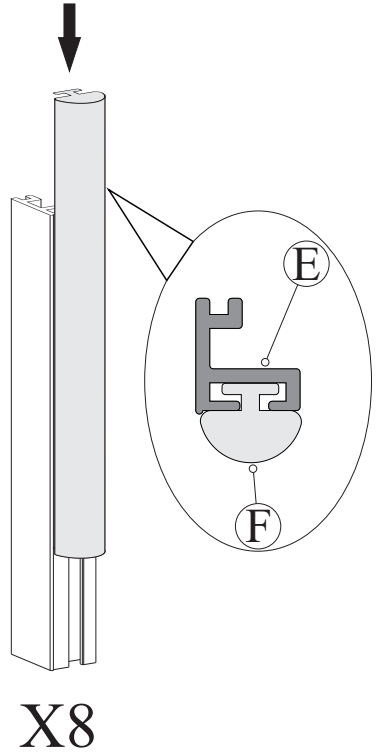
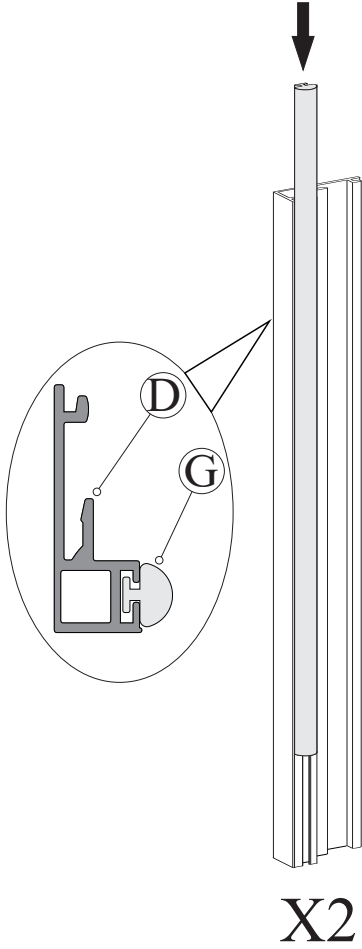

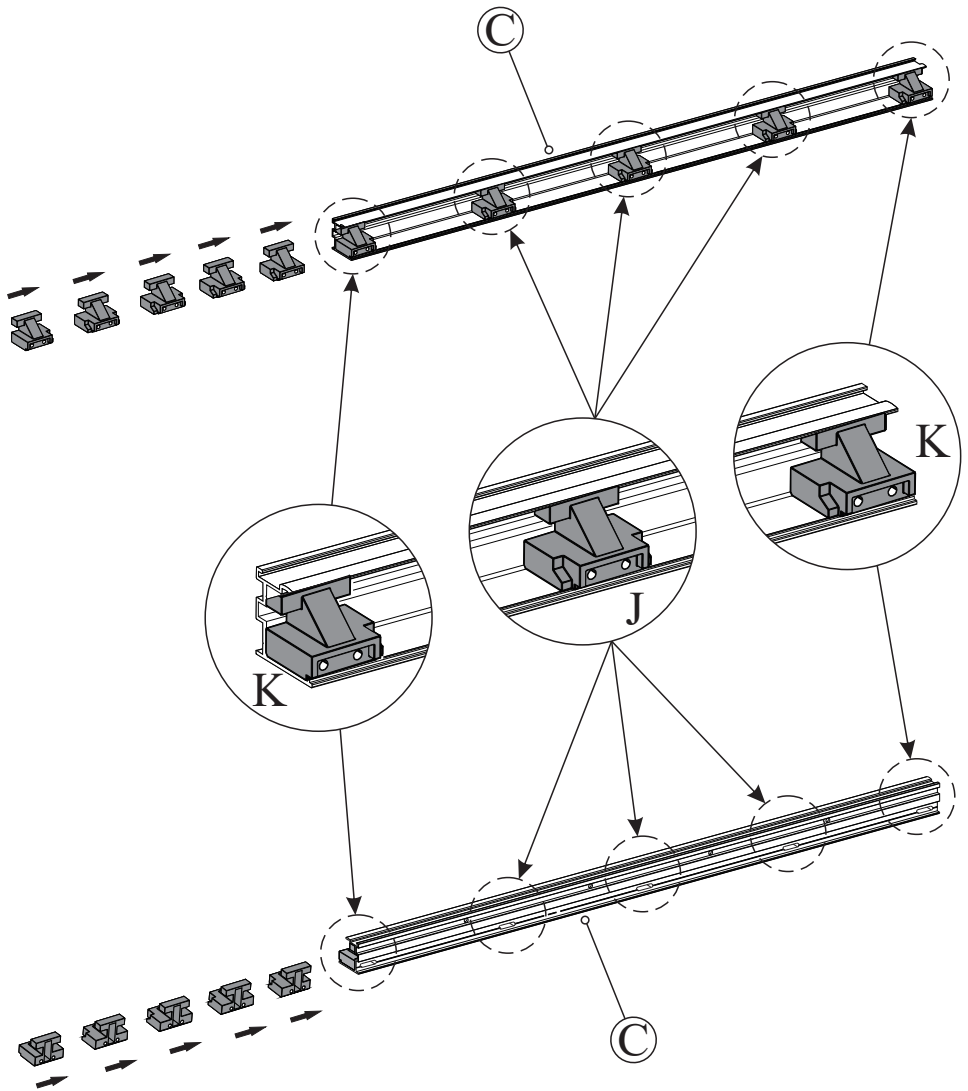

7

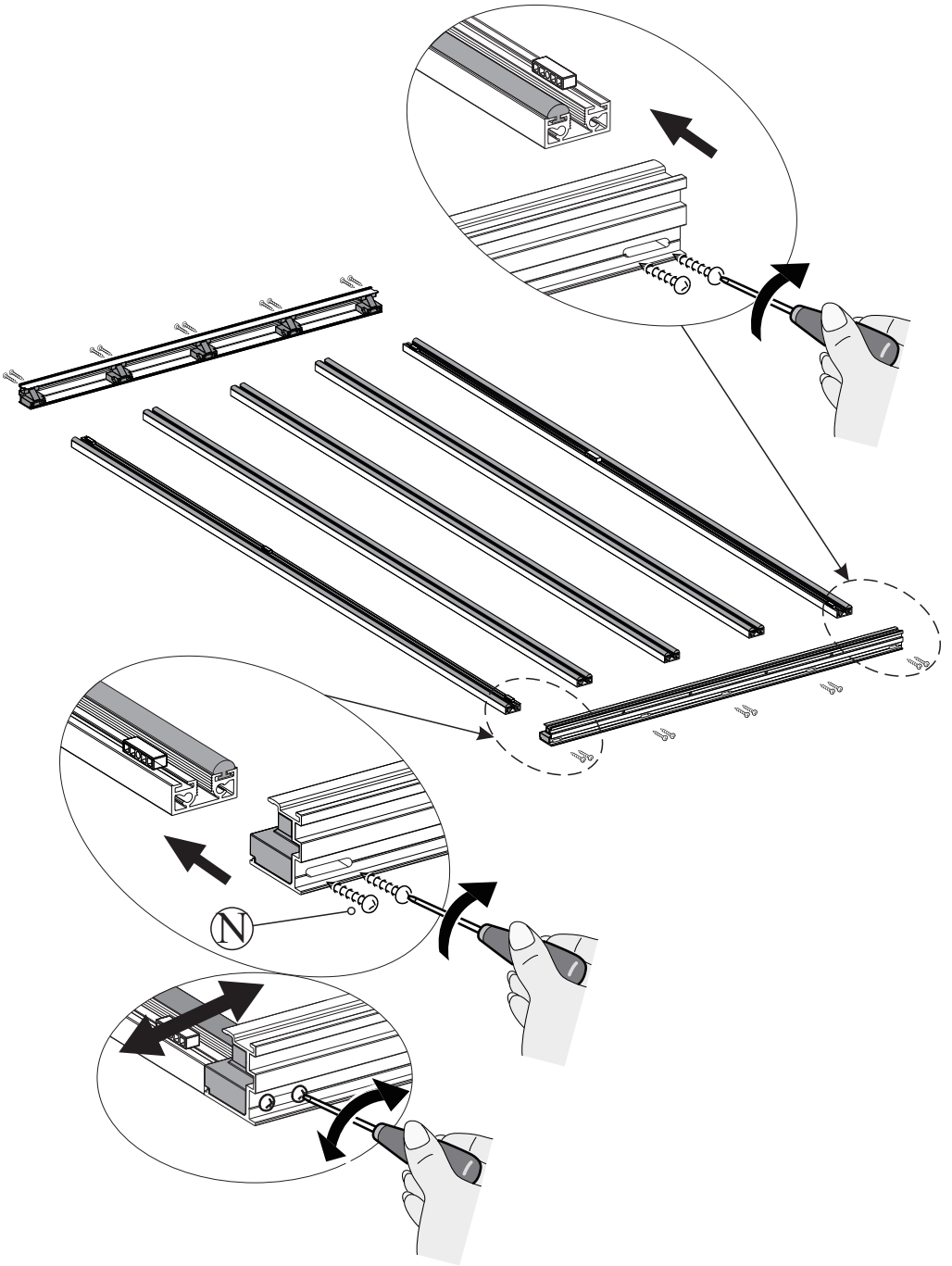

(7)

8

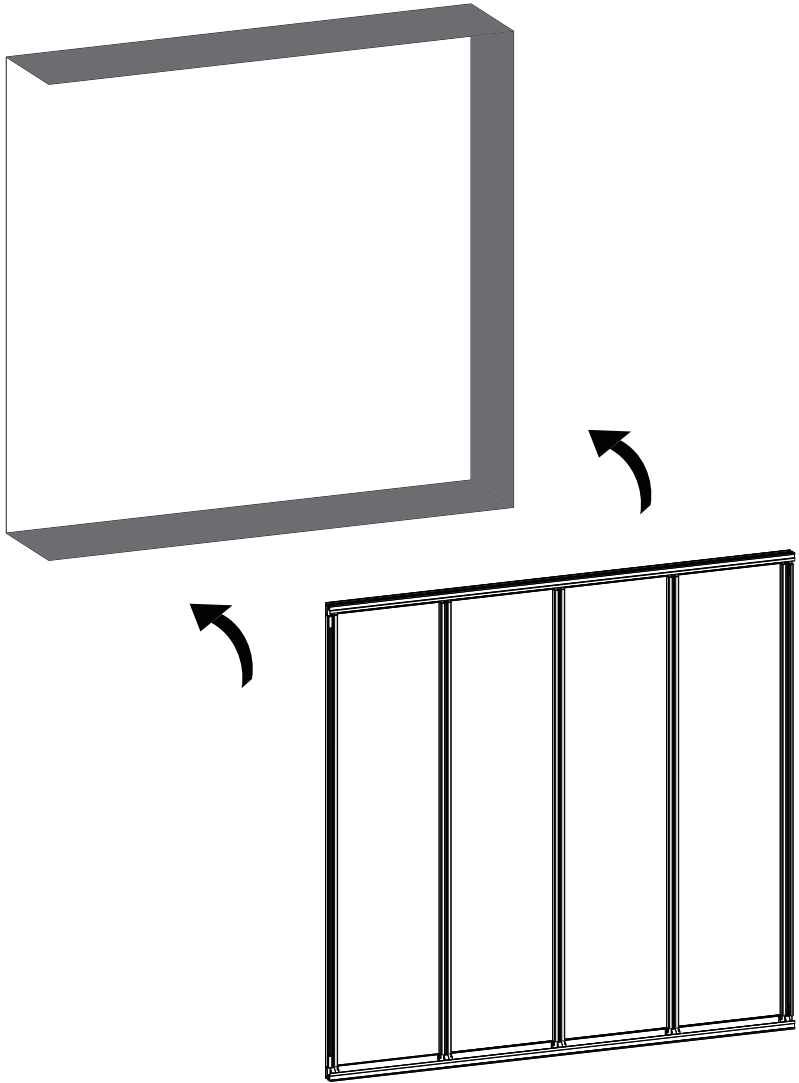

9

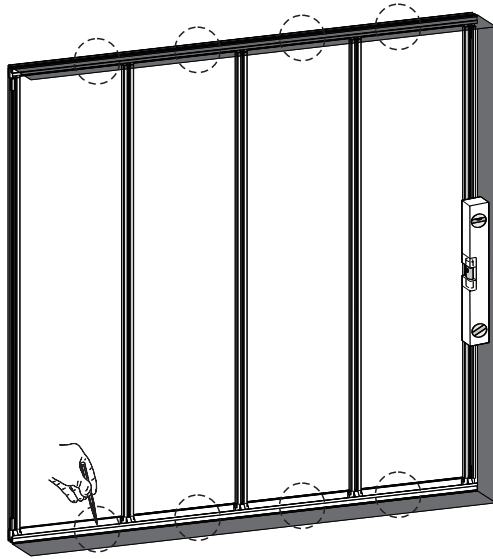

10

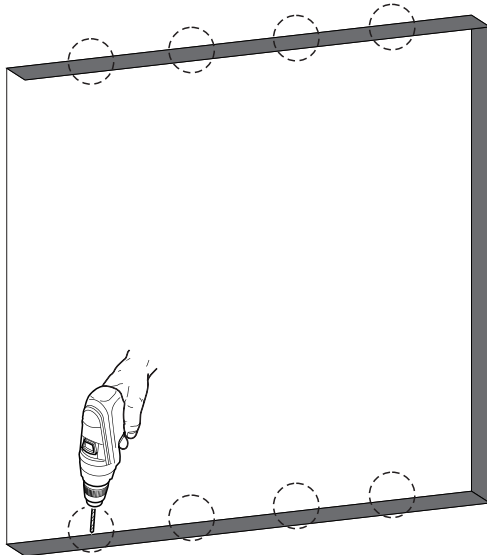

(9)

11

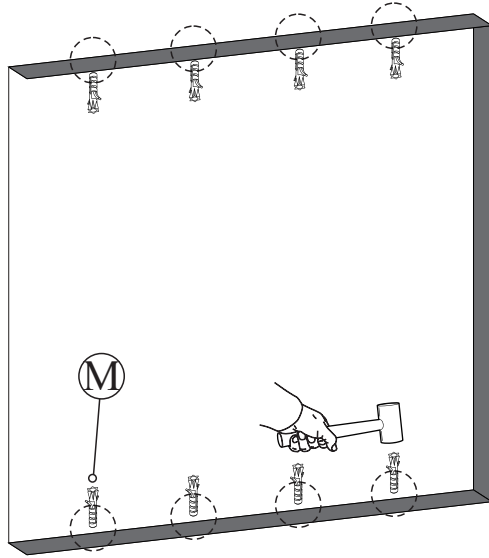

12

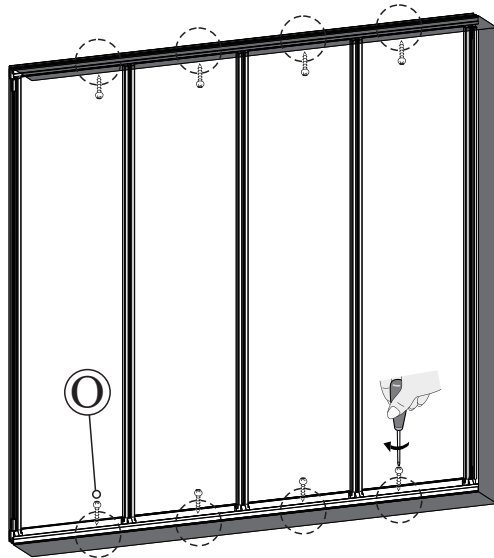

13

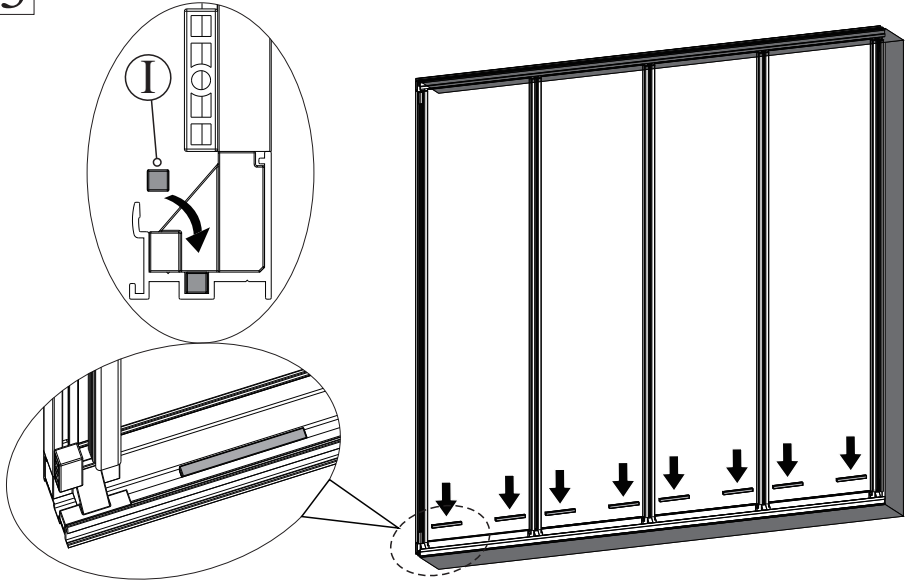

14

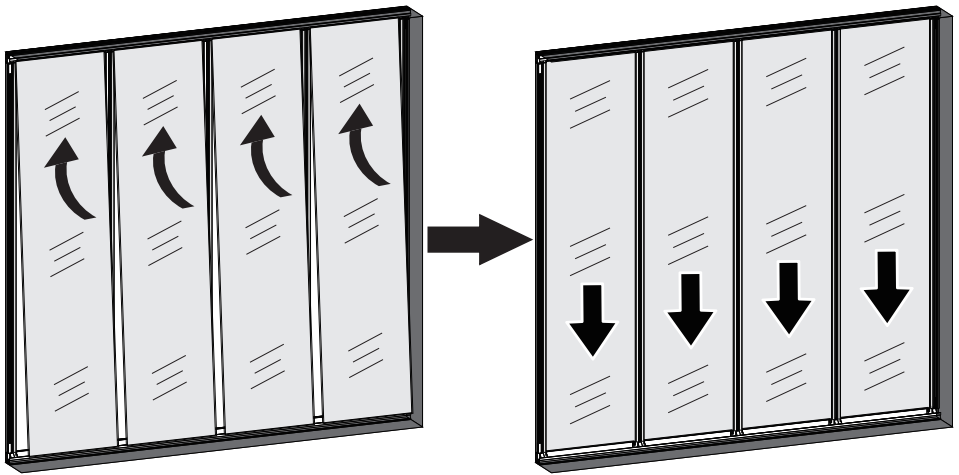

15

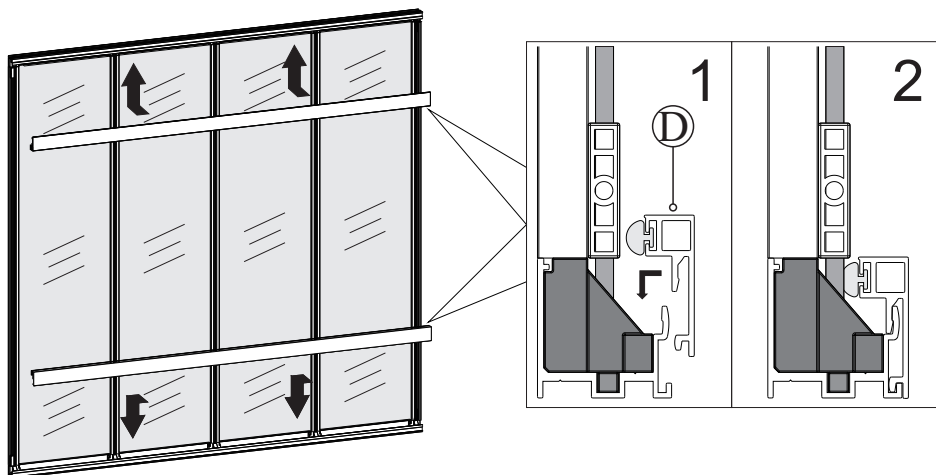

16

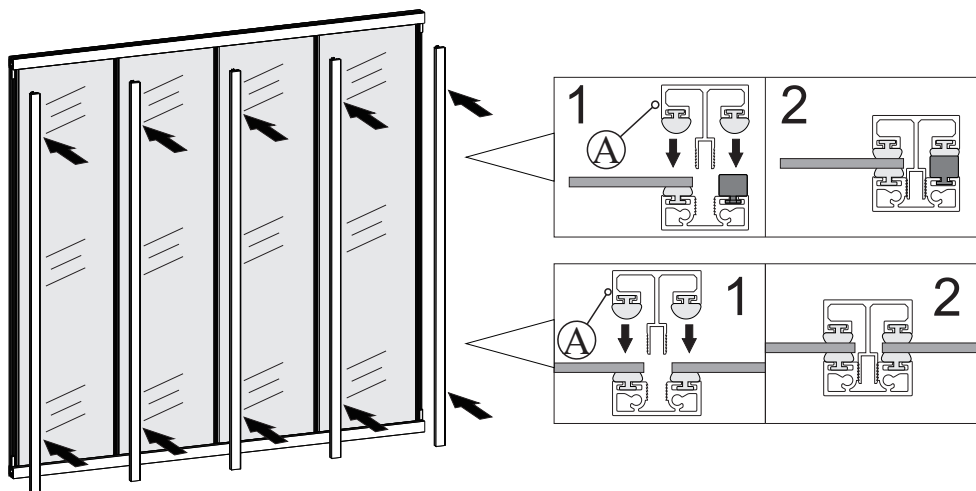

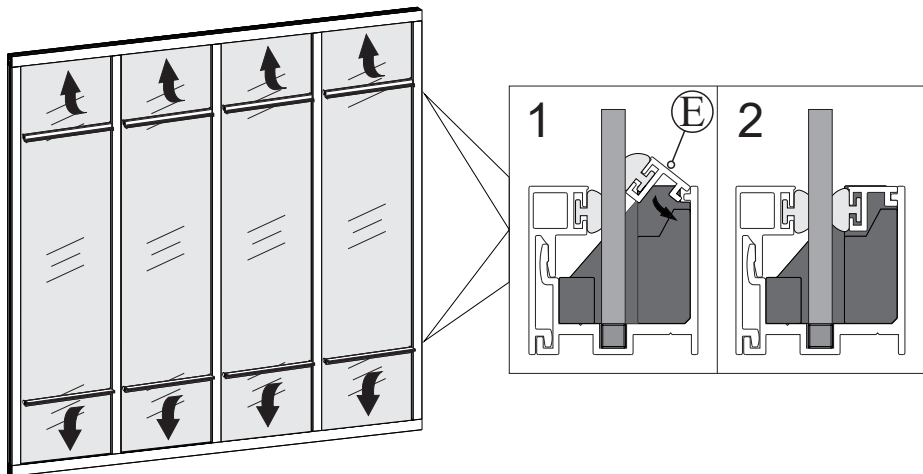

Cleaning & Maintenance

Clean the sundries regularly to prevent the drain from being jammed. Usually, clean the shower enclosure by mop with mild detergent.

Don't clean the shower enclosure with irritant detergent, such as alcohol, gasoline or other chemical cleaner.

Should there be any dirty stains on the shower enclosure, you may clean it by calico with toothpaste, but you need to clean it with water afterwards.

After the installation is completed, if you find there is much noise when the glass door moves, you may add small quantity of lubricant onto the roller wheel, slipping hook and the track.

Nettoyage & Entretien

Enlevez les déchets régulièrement afin d'éviter le blocage de la fuite.

En général, vous pouvez nettoyer la paroi de douche avec une serpillière et des détergents doux.

Veillez ne pas nettoyer la paroi de douche avec des détergents forts comme l'alcool, l'essence ou autres nettoyeurs chimiques.

S'il y a des taches sur la paroi, vous pouvez utiliser un calicot avec du dentifrice pour la nettoyer, cependant, vous devrez la rincer avec de l'eau après.

Lorsque vous finissez l'installation et s'il y a du bruit quand vous pivotez la porte, vous pouvez appliquer un peu de lubrifiant sur les rouleaux, les charnières et la glissière.

Pulizia e Manutenzione

Pulire il prodotto con uno straccio e sapone delicato, non utilizzare detersivi o saponi aggressivi chimici.

Dopo l'installazione se si sentono rumori all'apertura della porta o si fa fatica ad aprirla si consiglia di usare del lubrificante sulle cerniere per favorire lo scivolamento.

Limpieza y mantenimiento

Limpiar el desagüe regularmente para evitar que el drenaje se atasque.

Limpiar la cabina de ducha con trapo y detergente suave.

No limpiar la cabina de ducha con productos agresivos, como alcohol, gasolina u otro limpiador químico.

Si quedan manchas en la cabina de ducha puede limpiar usando pasta dental y luego agua.

Después que hay terminado la instalación, si nota algún sonido al mover las puertas, puede colocar un poco de aceite lubricante en los rodamientos y/o carril de guía.

CZYSZCZENIE I KONSERWACJA

Do prawidłowego czyszczenia należy używać łagodnych preparatów oraz miękkich ściereczek. Nie wolno czyścić drażniącymi detergentami takimi jak: alkohol, benzyna czy innymi środkami.

Plamy można usuwać za pomocą pasty do zębów nałożoną na ściereczkę (Po jego użyciu należy spłukać wodą).

Jeśli po instalacji kabiny drzwi skrzypią przy otwieraniu i zamykaniu, należy na elementy ruchome takie jak: rorki, uchwyty czy prowadnice nałożyć niewielką ilość środka smarującego.

W celu zapobieżenia zatkanie się odpływu zalecane jest usuwanie wszelkich zanieczyszczeń regularnie.