

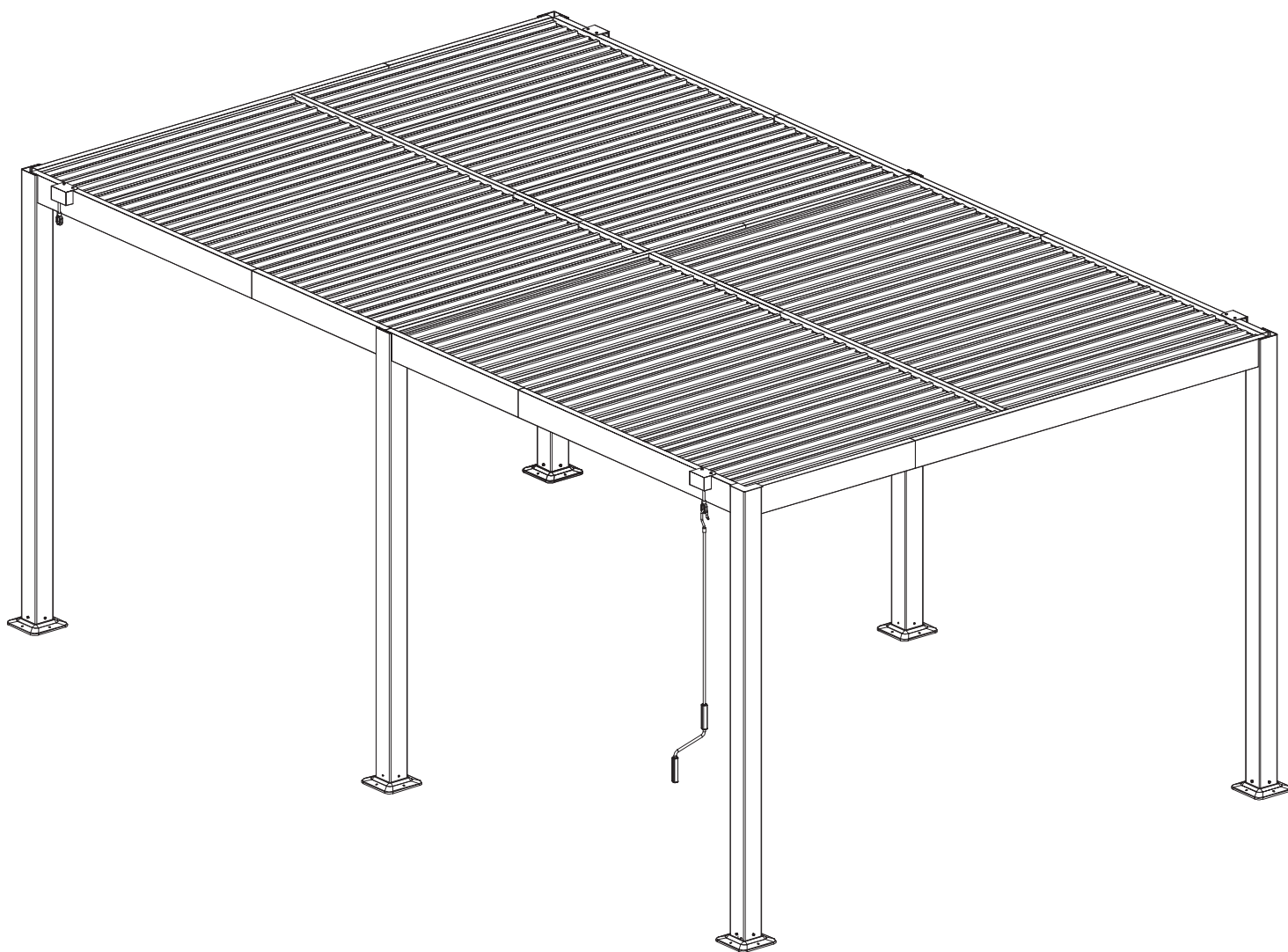

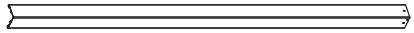

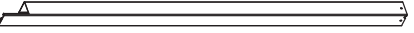















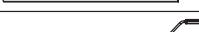
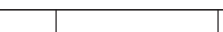

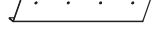





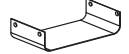





Pergola bioclimatique en aluminium "Neville"
- 3 x 5 m - Gris
1558_145641

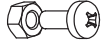

1558_145641

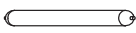
A		100x100x2170mm	X4	1/1					
B		100x100x2170mm	X2	1/1					
C		135x75x1969mm	X2	1/1					
D		135x75x915mm	X2	1/1					
E		135x75x1520mm	X2	1/1					
F		135x75x915mm	X2	1/1					
G		131x108x1523mm	X2	1/1					
H		131x108x900mm	X2	1/1					
I		135x75x1520mm	X2	1/1					
J		135x75x915mm	X2	1/1					
K		131x108x1972mm	X1	1/1					
L		131x108x918mm	X1	1/1					
M		162*20mm	X56	1/1					
N		162*20mm	X8	1/1					
O		800mm	X1	1/1					
P		210*210mm	X6	1/1	Q		600mm	X6	1/1
R		600mm	X3	1/1	S		100*40*60mm	X2	1/1
T		100*40*60mm	X2	1/1	X		100*35mm	X2	1/1
Y		100*100mm	X4	1/1	Z		110mm	X12	1/1
Z1		60mm	X3	1/1	Z2		25*100mm	X6	1/1
Z3		25*119mm	X2	1/1	Z4		M6*8mm	X16	1/1
Z5		M6*15mm	X262+8	1/1	Z6		M6*38mm	X24	1/1
Z7		6*46mm	X36	1/1	Z8			X4	1/1
Z9		20*60mm	X8	1/1	Z10		M4 M4*8mm	X12	1/1
Z11		M6*20mm	X10	1/1	Z12		ST4.2x25	X4	1/1
Z13			X128	1/1	Z14		50*300mm	X1	1/1
Z15		M6*62	X24	1/1	Z16				

FR : SAV/INFORMATION /VIDEO/CONTACT

EN: AFTER-SALES SERVICE/INFORMATION/VIDEO/CONTACT

DE : REPARATUR-SERVICE UND ERSATZTEILE /INFORMATIONEN /VIDEO/KONTAKT

ES: SERVICIO POST-VENTA/INFORMACION/VIDEO/CONTACTO

IT: SERVIZIO ASSISTENZA/INFORMAZIONI/VIDEO/CONTATTO

PT: SERVIÇO POS-VENDA/INFORMAÇÕES/VIDEO/CONTATO

PL: SERWIS TECHNICZNY/INFORMACJE/WIDEO/KONTAKT

NE: AFTER SALES SERVICE/INFORMATIE/VIDEO/CONTACT

HE: מע רשקתל/ואדיוור/ עדימ/תורכמו תוריש רחאל:

SAV.HABITATETJARDIN.COM

2025-2026

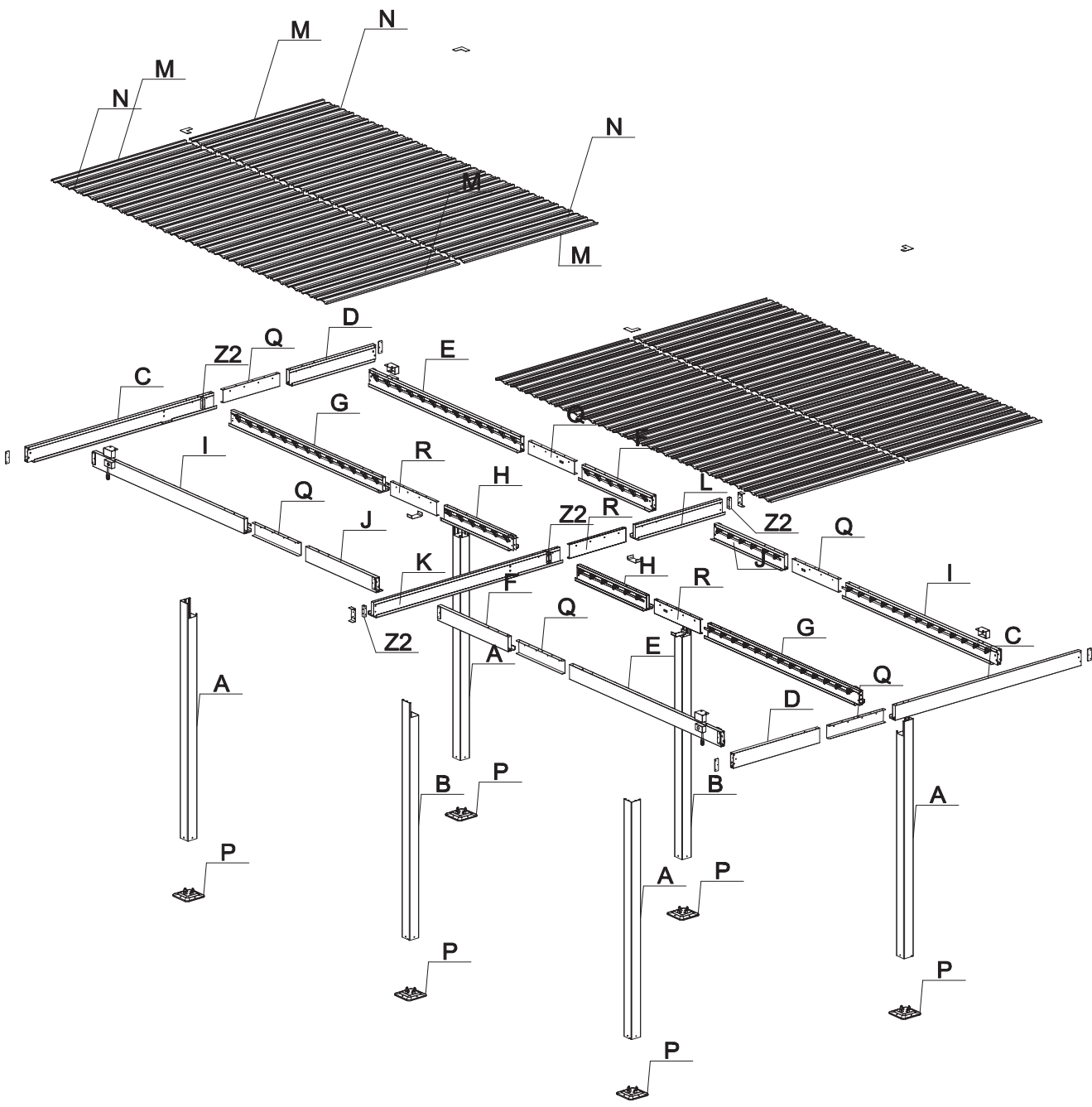

Note : Le kiosque doit être installé en collaboration avec six personnes. Les outils suivants ne sont pas inclus, mais nécessaires pour l'assemblage :

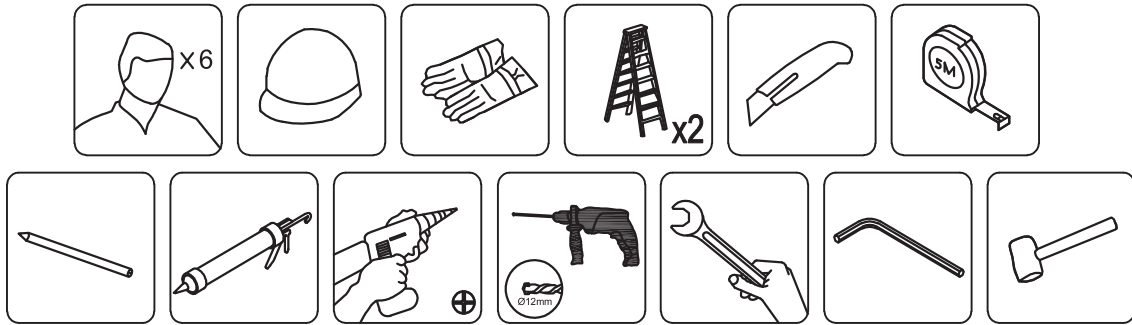

Attention:

1. Un assemblage de 6 personnes est requis pour ce gazebo.
2. Veuillez prendre les mesures appropriées car de fortes pluies, le vent et la neige peuvent endommager le gazebo. Si nécessaire, veuillez démonter et stocker pour une utilisation ultérieure.
3. Dans des conditions enneigées, s'il vous plaît ne laissez pas l'épaisseur de la neige à plus de 1, 97 pouces sur le toit, cela devrait être dégagé dès que possible pour votre sécurité. Lorsque la vitesse du vent atteint 61.2km/h, veuillez prendre des mesures pour éviter le vent.

ATTENTION:

1. Veuillez vérifier le manuel soigneusement et assurez-vous que vous avez reçu toutes les pièces.
2. S'il y a des manquants, s'il vous plaît laissez-nous savoir la lettre du Pièces dont vous avez besoin.
3. S'il y a des dommages, s'il vous plaît envoyez-nous des photos d'clear, nous allons vérifier et vous offrir la meilleure solution bientôt.

Note: The gazebo needs to be installed in cooperation with Six people. The following tools are not included ,but needed for assembly:

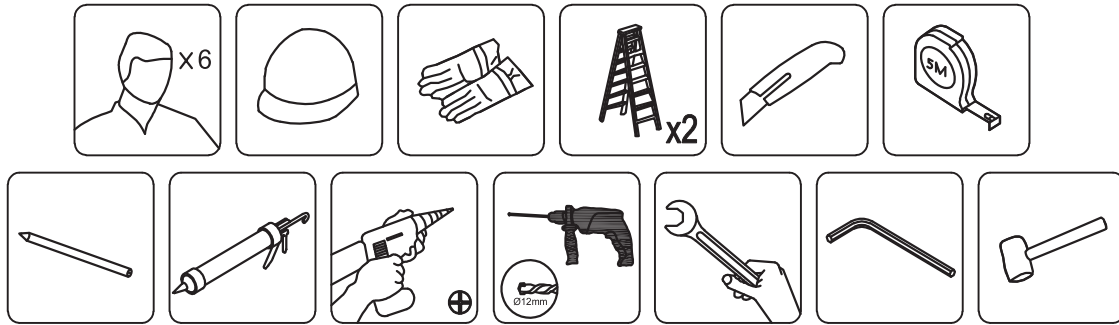

Warning

1. A 6 person assembly is required for this gazebo.
2. Please take appropriate actions as heavy rain, wind and snow can damage the gazebo. If necessary please disassemble and store for later use.
3. In snowy conditions, please do not allow the thickness of the snow to be more than 1.97 inches on the roof, this should be cleared as soon as possible for your safety. When the wind speed reaches 61.2km/h, please take measures to avoid the wind.

ATTENTION:

1. Please check the manual carefully and make sure you have received all the parts.
2. If there is any missing, please let us know the letter of the parts you need.
3. If there is any damage, please send clear photos to us, we will check and offer you the best solution soon.

Anmerkung: der aufbau des pavilion kostet sechs partner Folgende werkzeuge sind nicht eingeschlossen, die aber zusammengesetzt werden müssen:

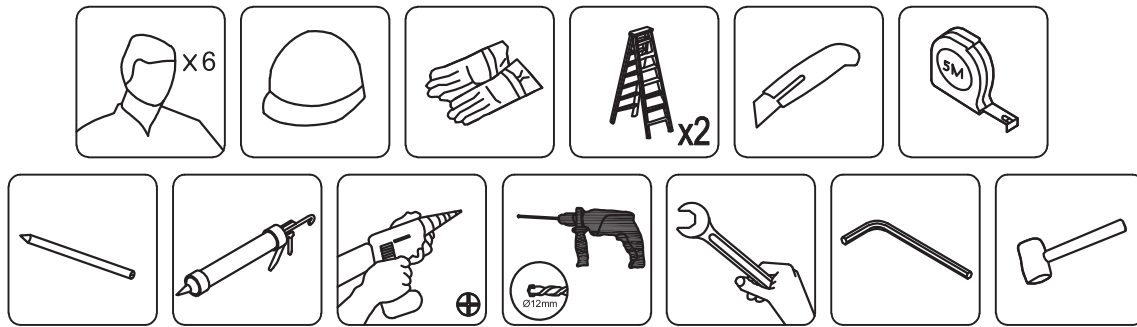

Das eingehende signal

1. Dieser pavillon muss Von sechs personen aufgebaut werden.
2. Wenn Regen, wind und schnee schaden anrichten, dann ergreifen sie bitte geeignete maßnahmen. Wenn nötig, Trennen sie ab und speichern sie es für später.
3. Die schneedecke auf dem dach nicht mehr als 1,97 cm Dick machen, wenn schnee fällt. Zu ihrer eigenen sicherheit sollten sie schnell gesäubert werden. Bei windgeschwindigkeiten Von 61.2km/h ist folgendes zu befürchten:

"Nichts für schwache nerven!"

1. Bitte prüfen sie die gebrauchsanweisung genau, ob sie alle teile bekommen haben.
2. Im falle eines verlusts, teilen sie bitte den empfänger ihres schreibens mit Sie brauchen das ersatzteil.
3. Wenn irgendwas kaputt geht, schicken sie uns bitte ein gutes foto, wir prüfen das und geben ihnen so schnell wie möglich die beste lösung.

Nota: el gazebo necesita ser instalado en cooperación con seis personas. Las siguientes herramientas no están incluidas, pero son necesarias para el montaje:

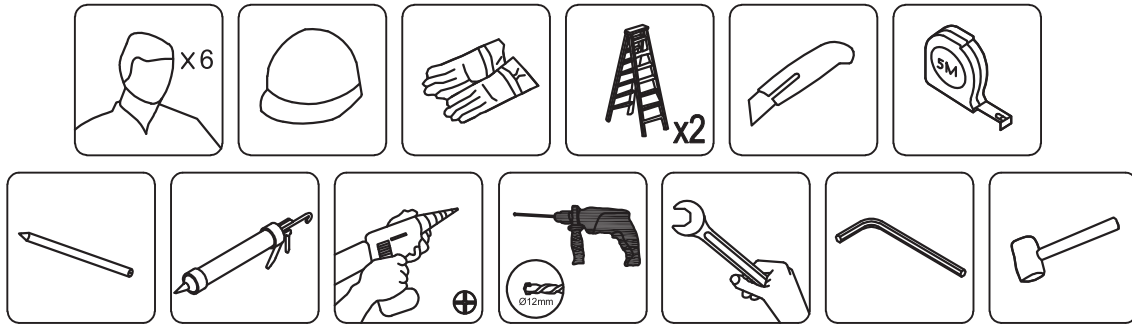

Advertencia:

1. Se requiere una Asamblea de 6 personas para este gazebo.
2. Por favor tomen las acciones apropiadas ya que las fuertes lluvias, el viento y la nieve pueden dañar el gazebo. Si es necesario, desmontar y almacenar para su uso posterior.
3. En condiciones de nieve, por favor no permita que el espesor de la nieve sea más de 1,97 pulgadas en el techo, esto debe ser despejtan tan pronto como sea posible para su seguridad. Cuando la velocidad del viento alcance 61.2km/h, por favor tome medidas para evitar el viento.

Atención:

1. Por favor revise el manual cuidadosamente y asegúrese de que ha recibido todas las partes.
2. Si hay alguna falta, por favor háganos saber la carta de la Piezas que necesita.
3. Si hay algún daño, por favor envíe fotos dlear a nosotros, vamos a comprobar y ofrecerle la mejor solución pronto.

Nota: il gazebo deve essere installato in cooperazione con sei persone. I seguenti strumenti non sono inclusi, ma necessari per il montaggio:

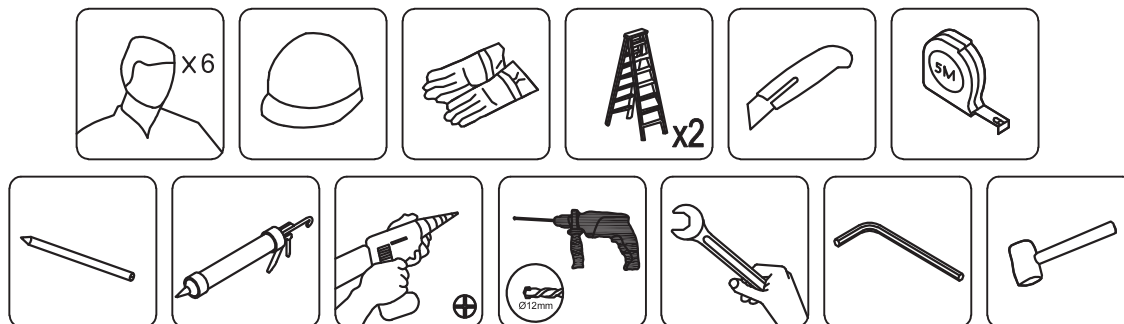

Attenzione:

1. Per questo gazebo è necessaria un'assemblea di 6 persone.
2. Si prega di intraprendere azioni appropriate in quanto pioggia pesante, vento e neve possono danneggiare lo sguardo. Se necessario, smontare e conservare per un uso successivo.
3. In condizioni di neve, non permettere che lo spessore della neve sia superiore a 1,97 pollici sul tetto, questo deve essere pulito il prima possibile per la sicurezza. Quando la velocità del vento raggiunge 61,2 km/h, adottare misure per evitare il vento.

Attenzione:

1. Controllare attentamente il manuale e assicurarsi di aver ricevuto tutte le parti.
2. Se ve ne sono, fateci conoscere la lettera della Parti di cui hai bisogno.
3. Se ci sono danni, per favore inviateci le foto di dlear, controlleremo e vi offriremo presto la soluzione migliore.

**Uwaga: Altana musi być zainstalowana we współpracy z sześcioma osobami.
Następujące narzędzia nie są dołączone, ale są potrzebne do montażu:**

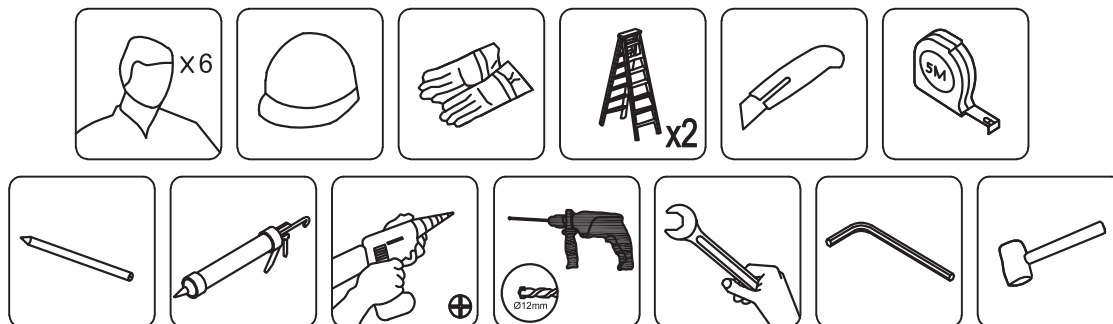

Ostrzeżenie:

1. Do tej altany wymagany jest montaż 6 osób.
2. Prosimy o podjęcie odpowiednich działań, ponieważ ulewny deszcz, wiatr i śnieg mogą uszkodzić altanę. W razie potrzeby należy zdemontować i przechowywać do późniejszego wykorzystania.
3. W warunkach śnieżnych nie pozwól, aby grubość śniegu na dachu przekraczała 1,97 cala, należy to usunąć tak szybko, jak to możliwe dla Twojego bezpieczeństwa. Gdy prędkość wiatru osiągnie 61,2 km/h, należy podjąć środki w celu uniknięcia wiatru.

UWAGA:

1. Sprawdź dokładnie instrukcję i upewnij się, że otrzymałeś wszystkie części.
2. Jeśli czegoś brakuje, poinformuj nas o literze części, których potrzebujesz.
3. Jeśli wystąpią jakiegokolwiek uszkodzenia, prześlij nam zdjęcia dlear, sprawdzimy i wkrótce zaoferujemy najlepsze rozwiązanie.

Opmerking: het paviljoen moet in samenwerking met 6 personen worden geïnstalleerd. De volgende gereedschappen zijn niet inbegrepen, maar moeten worden geassembleerd:

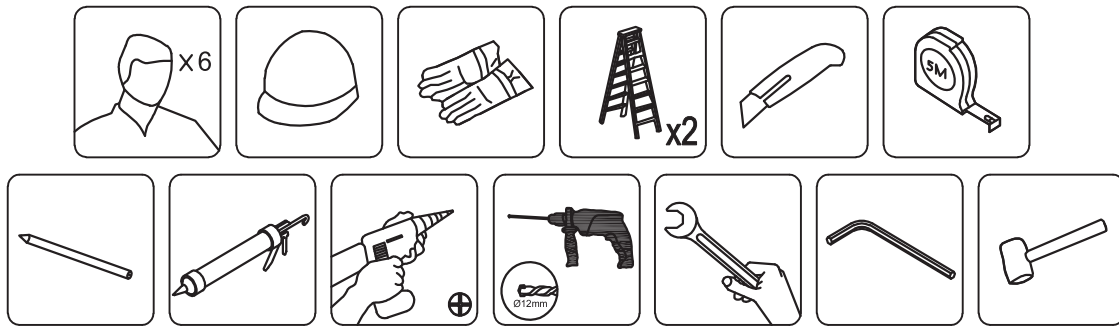

Waarschuwing:

1. Deze gazebo vereist een montage van 6 personen.
2. Regen, wind en sneeuw kunnen schade toebrengen aan het paviljoen. Indien nodig demonteren en opslaan voor later gebruik.
3. In het geval van sneeuw, laat de sneeuw op het dak niet meer dan 1,97 inch dik, dit moet zo snel mogelijk worden verwijderd voor uw veiligheid. Neem beschutting tegen de wind wanneer de windsnelheid 61,2 km/h bereikt.

Opmerking:

1. Controleer de handleiding zorgvuldig om er zeker van te zijn dat u alle onderdelen hebt ontvangen.
2. In geval van verlies, gelieve de geadresseerde te informeren over de brief De onderdelen die je nodig hebt.
3. In geval van schade, stuur ons duidelijke foto's, wij zullen controleren en u de beste oplossing zo snel mogelijk.

1



A x4



B x2

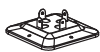





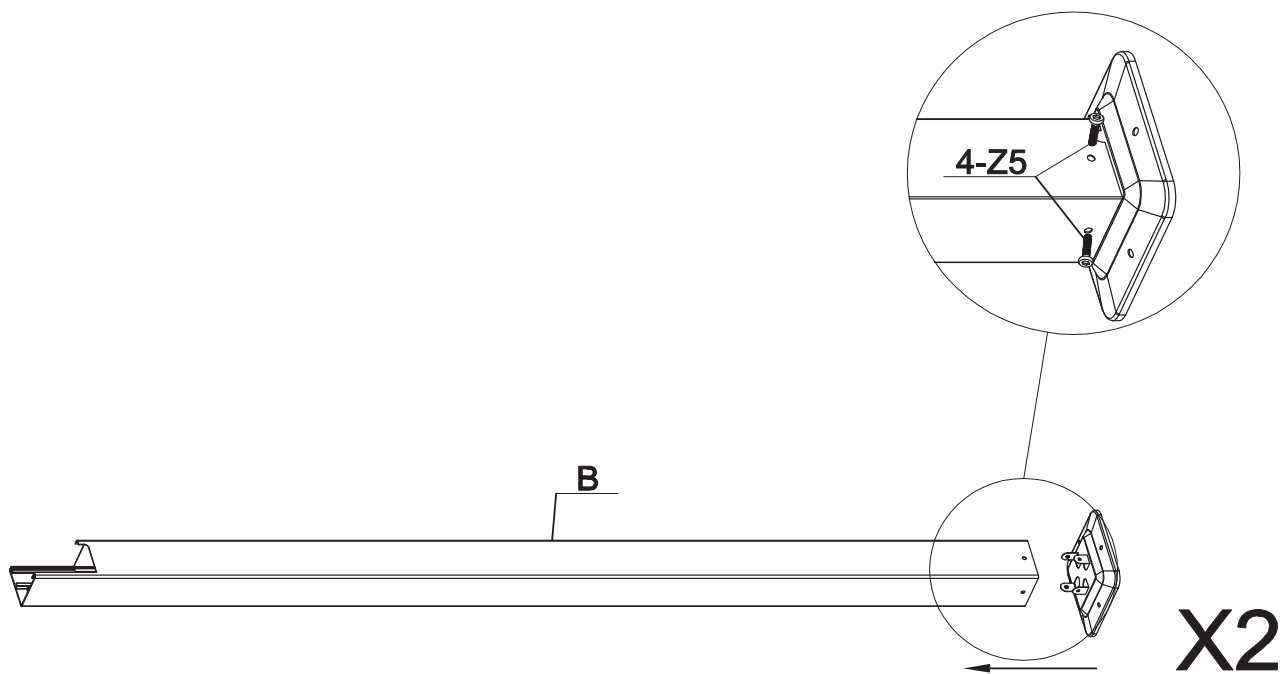
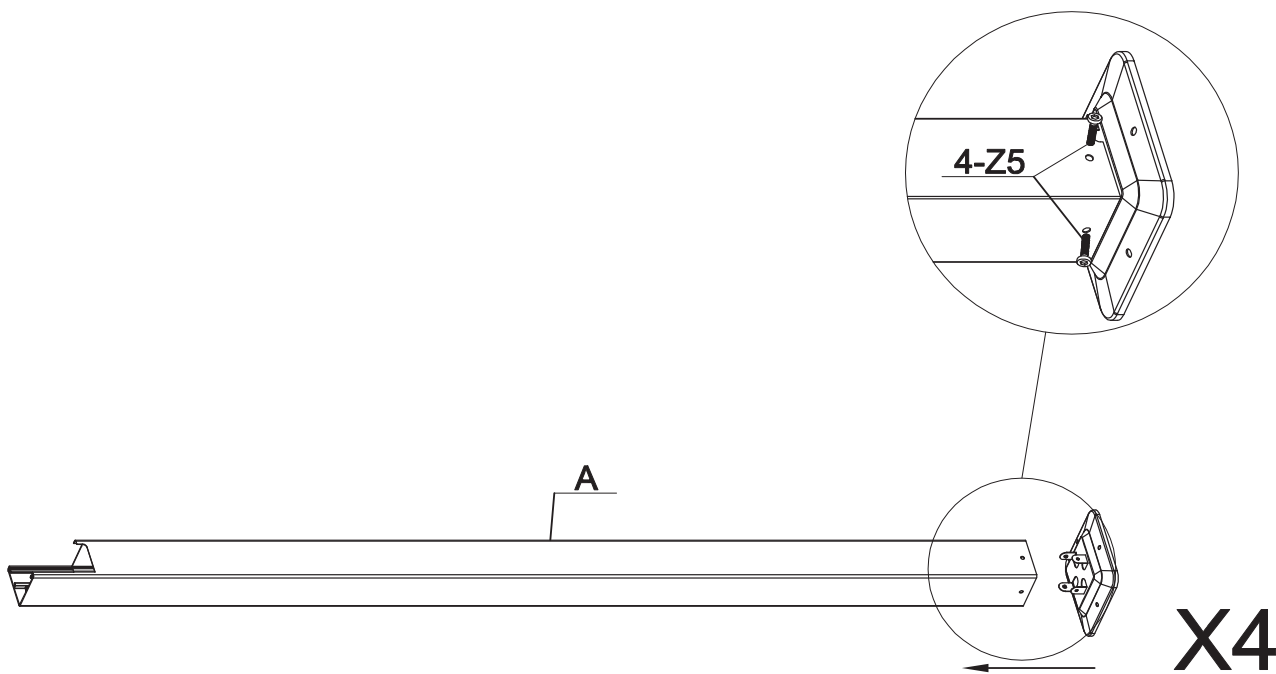

P x6



Z5 x24







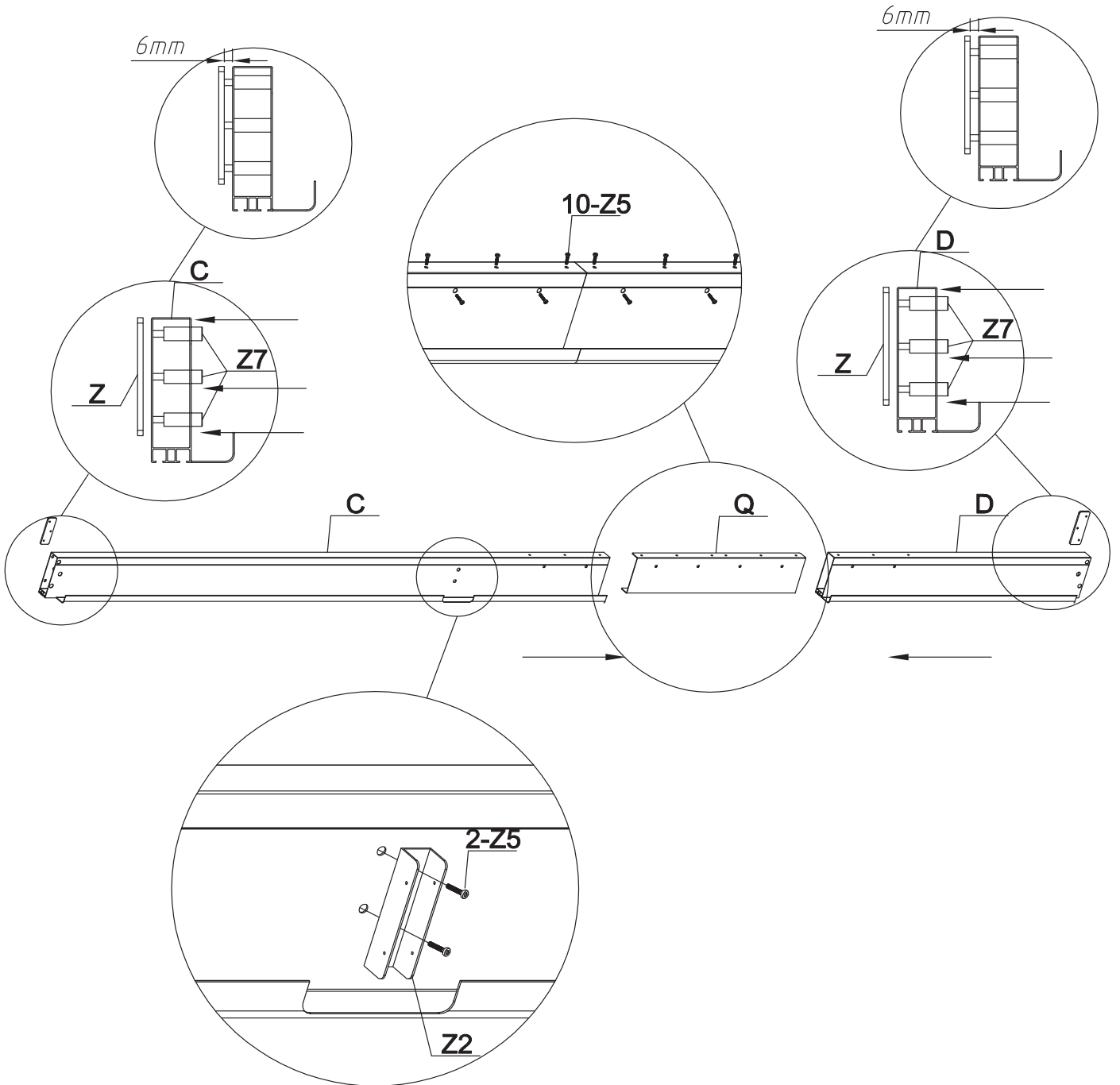



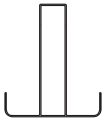

2025-2026

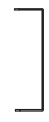
2	 C x2	 D x2	 Z x4	 Z2 x2	 Z7 x12	 Z5 x24	 Q x2
----------	---	---	---	--	---	---	---

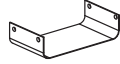





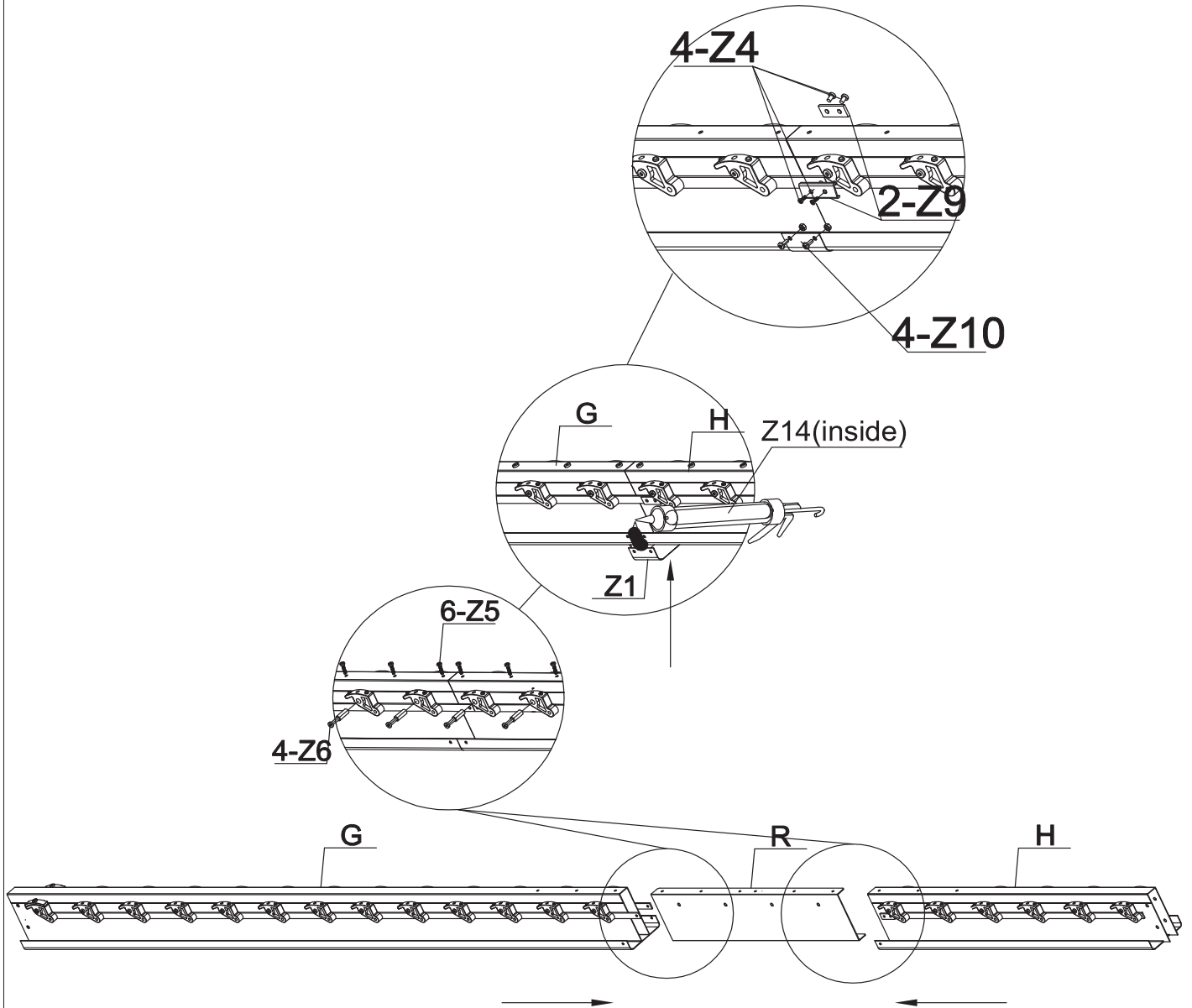

X2

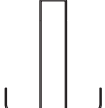

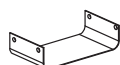

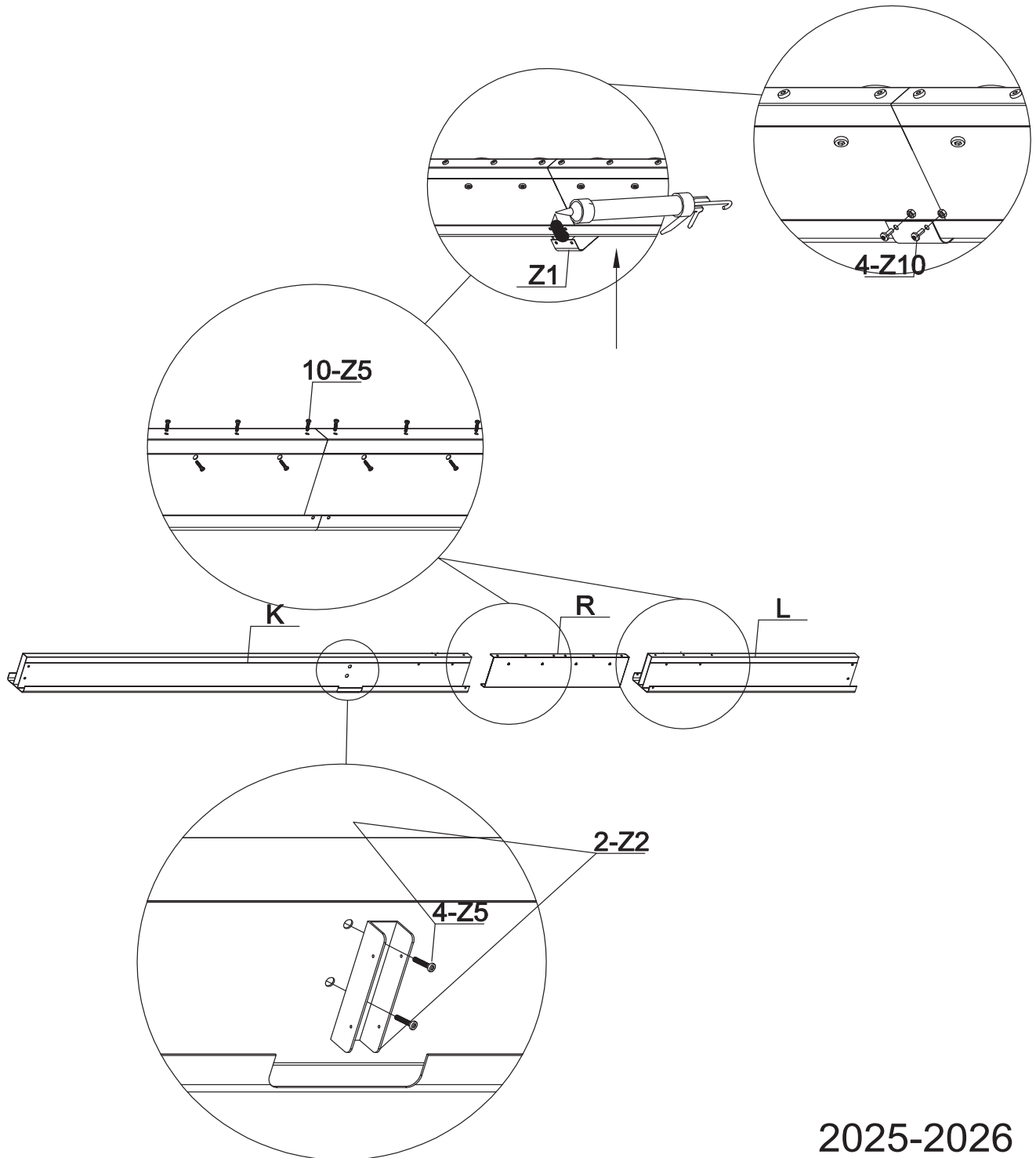

2025-2026

③							
	G x2	H x2	R x2	Z9 x4	Z1 x2	Z4 x8	Z5 x12
							
	Z6 x8	Z10 x8	Z14 x1				









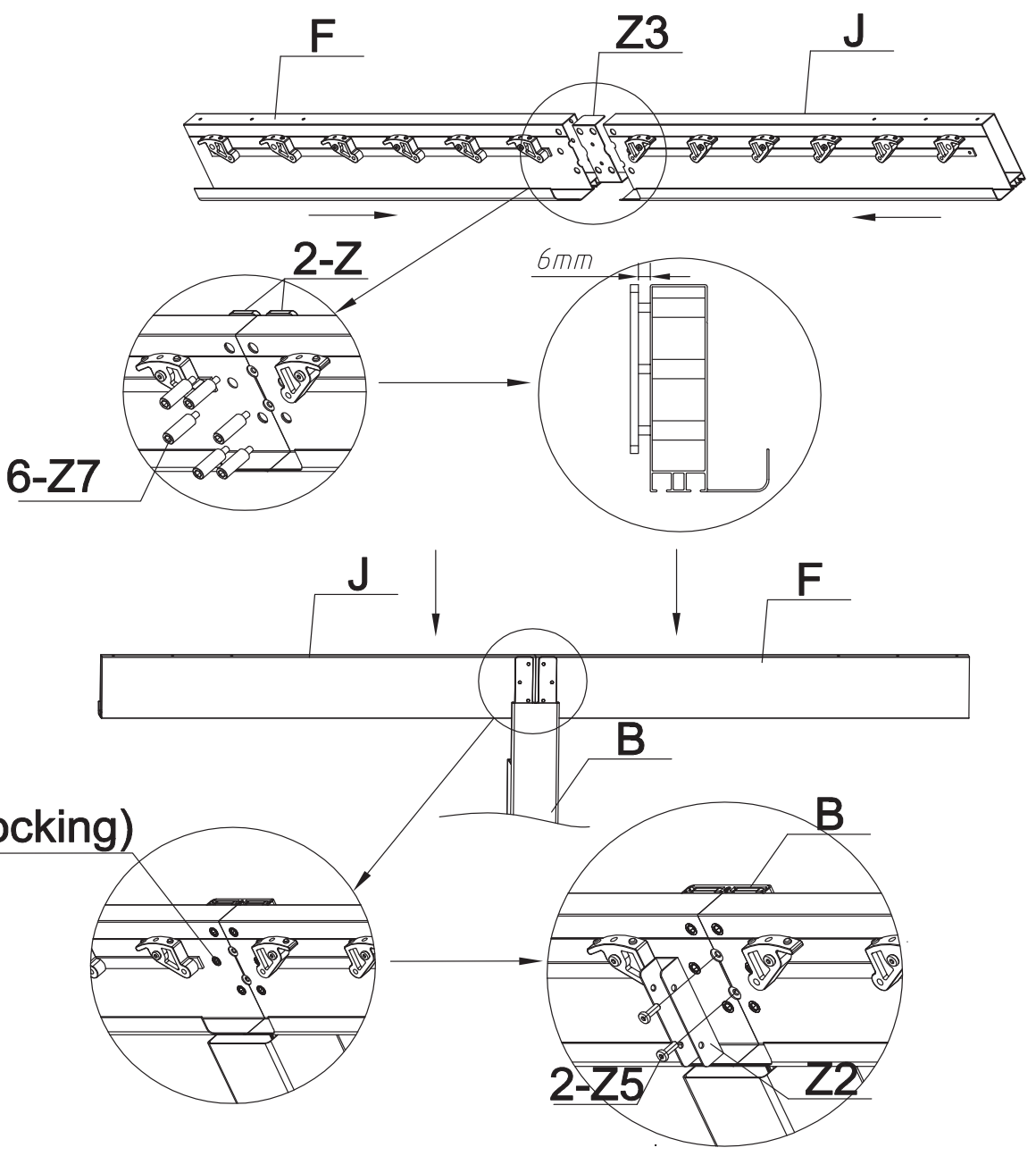

<p>④</p>	 <p>K x1</p>	 <p>L x1</p>	 <p>R x1</p>	 <p>Z1 x1</p>	 <p>Z5 x14</p>	 <p>Z2 x2</p>	 <p>Z10 x4</p>
----------	--	--	--	---	---	---	--



⑤	 F x2	 J x2	 Z3 x2	 Z x4	 Z7 x12	 Z2 x2	 Z5 x4
---	--	--	---	--	--	---	---

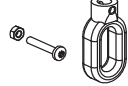

⑥	 E x2	 I x2	 Z6 x16	 Z x4	 Z7 x12	 Q x4	 Z5 x24
	 Z9 x4	 Z4 x8	 Z8 x4				

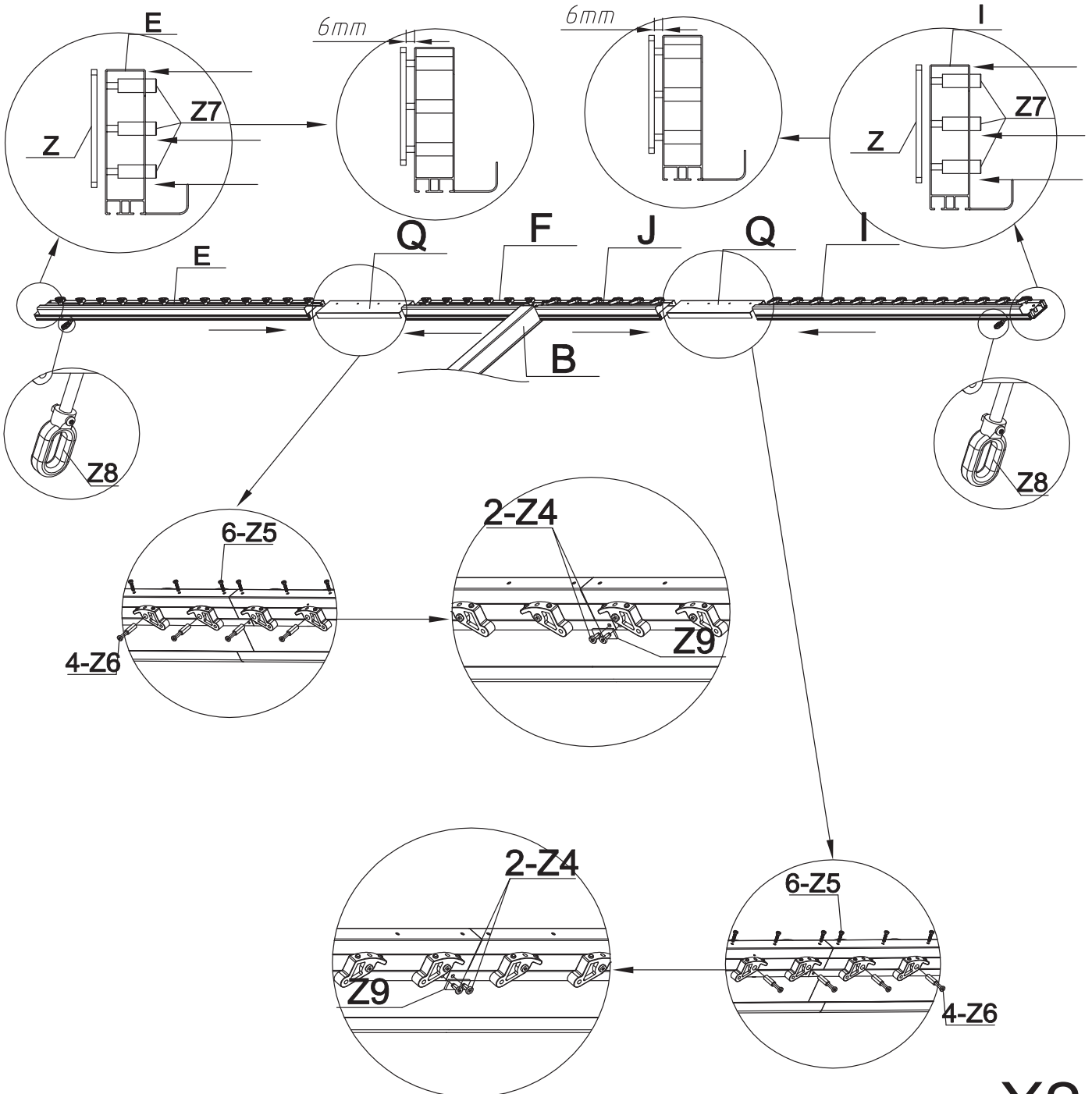

X2
2025-2026

7

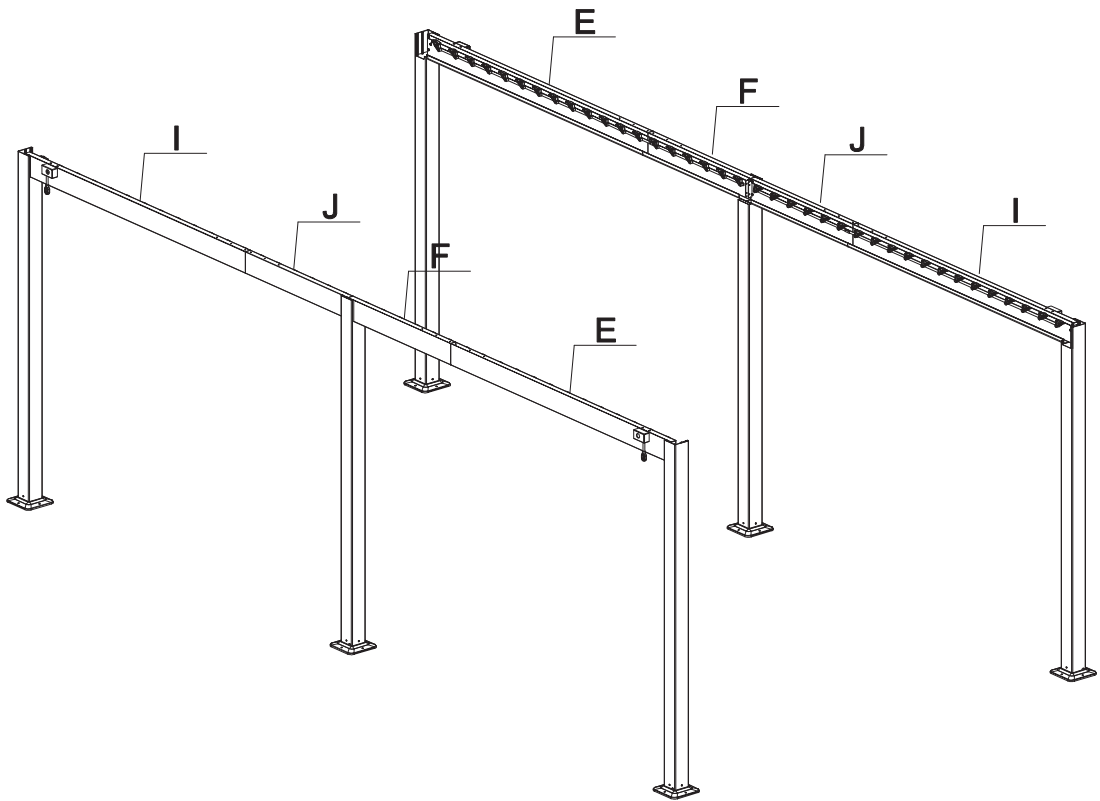
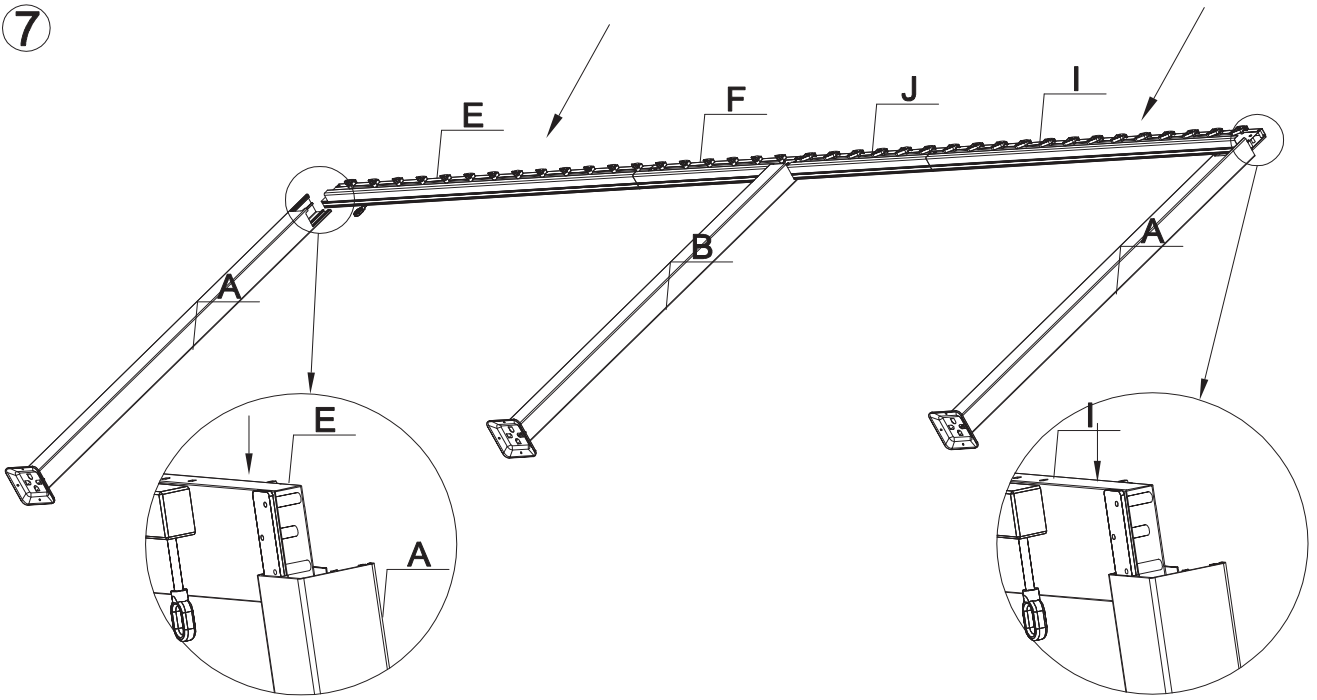

8



Z5 x16







S x2

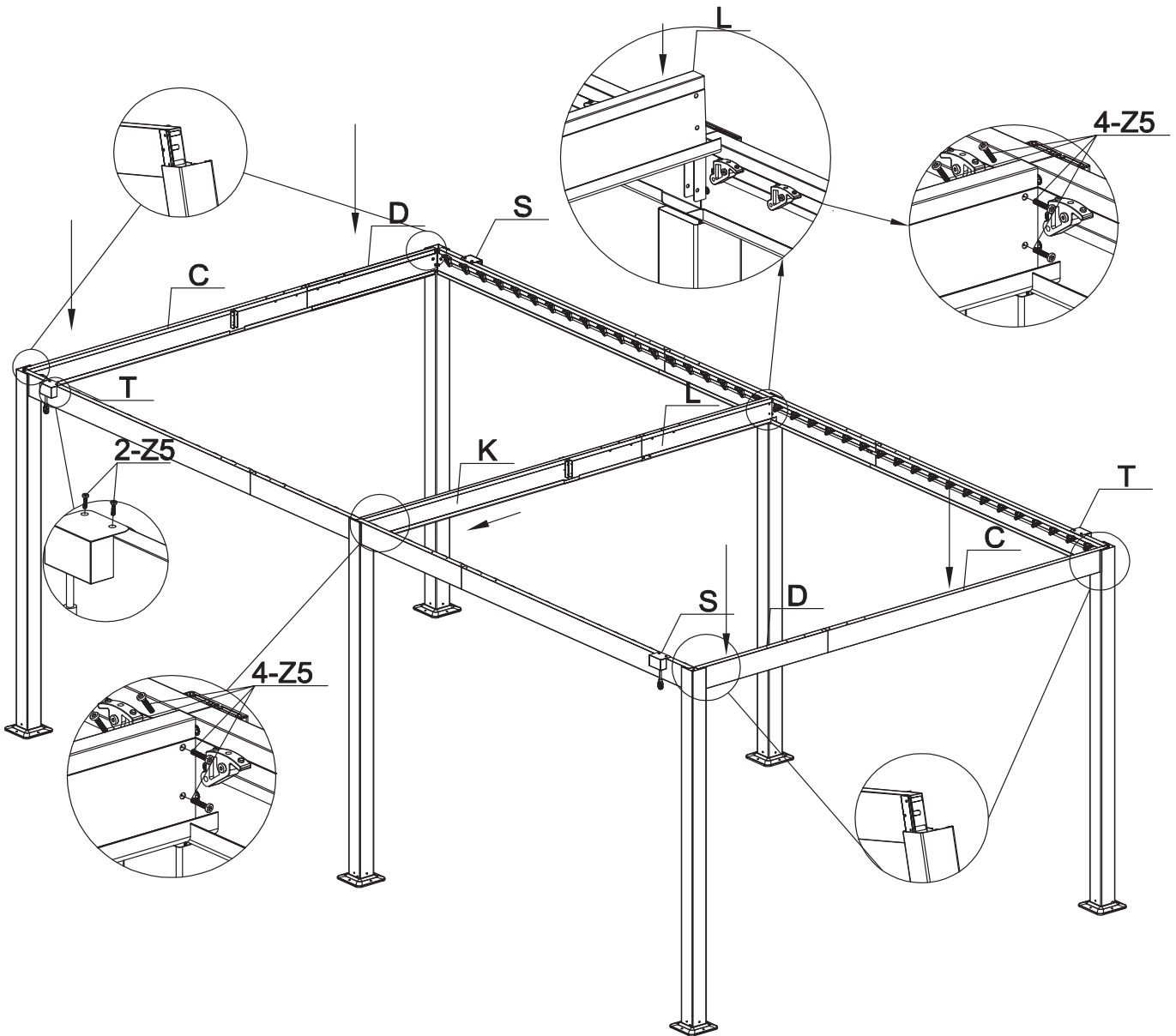

T x2



<p>9</p>	 Z5 x16	 Y x4	 X x2	 Z11 x10	 Z12 x4	
----------	---	---	---	--	--	--

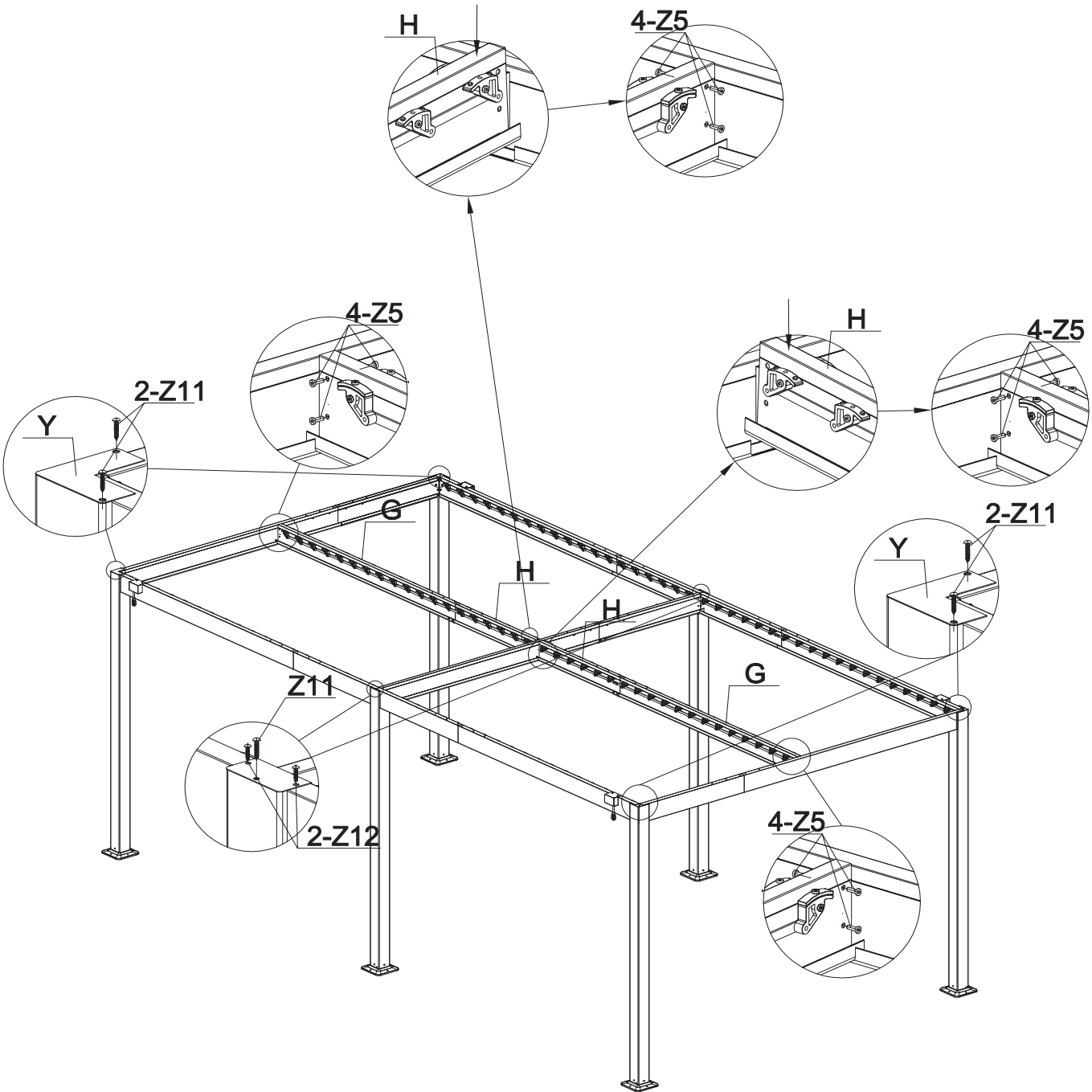

10



Z15 x24

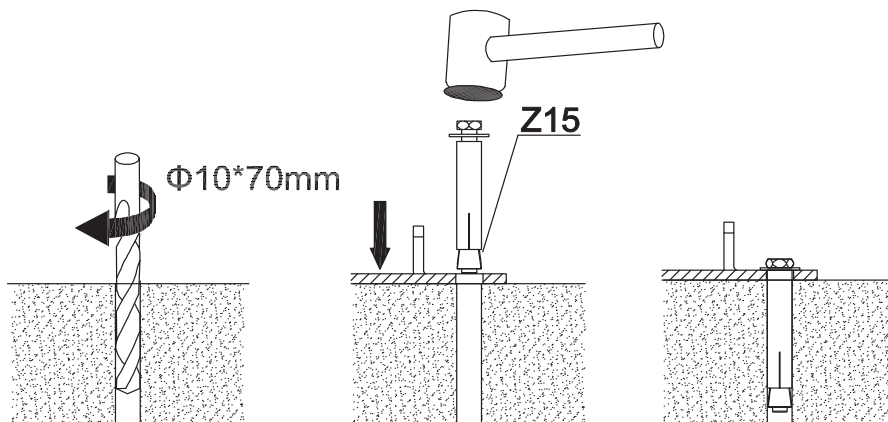
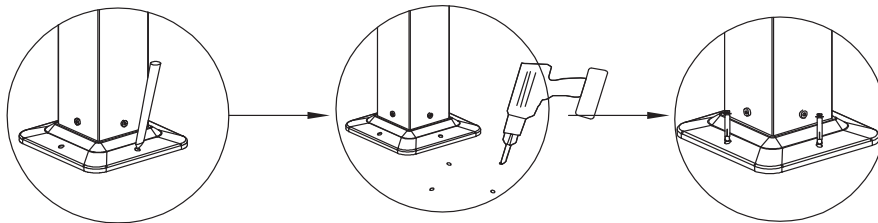
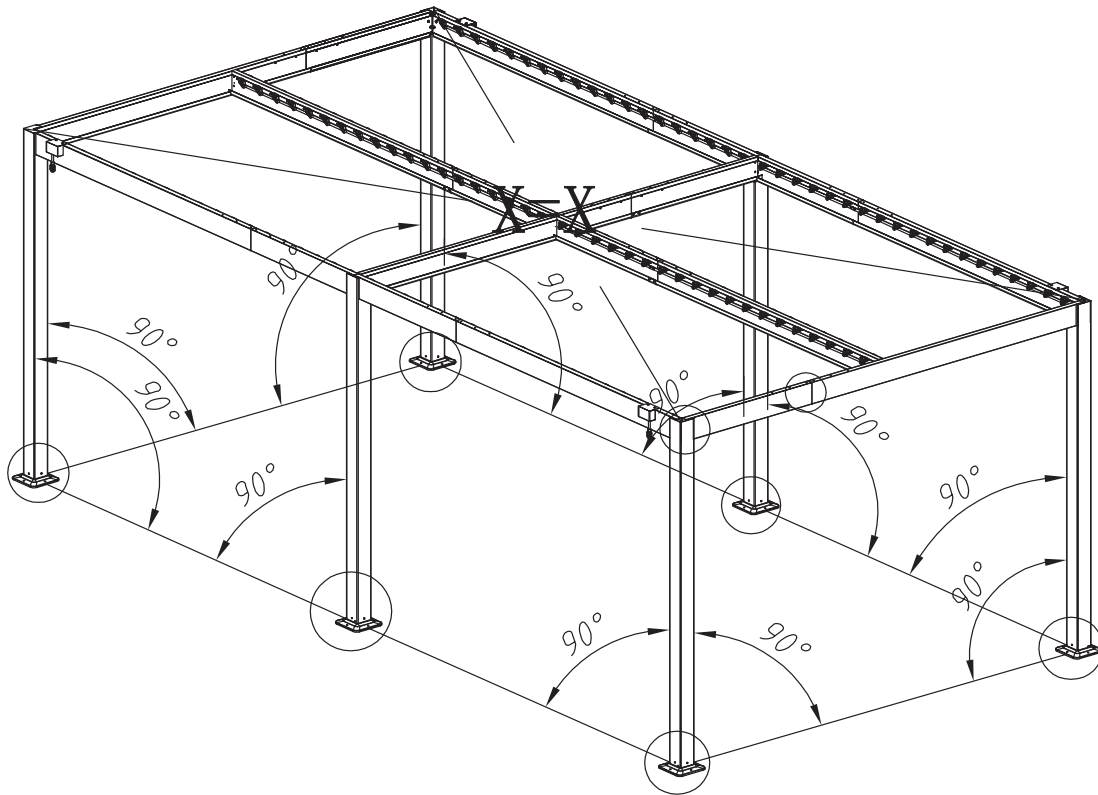

11

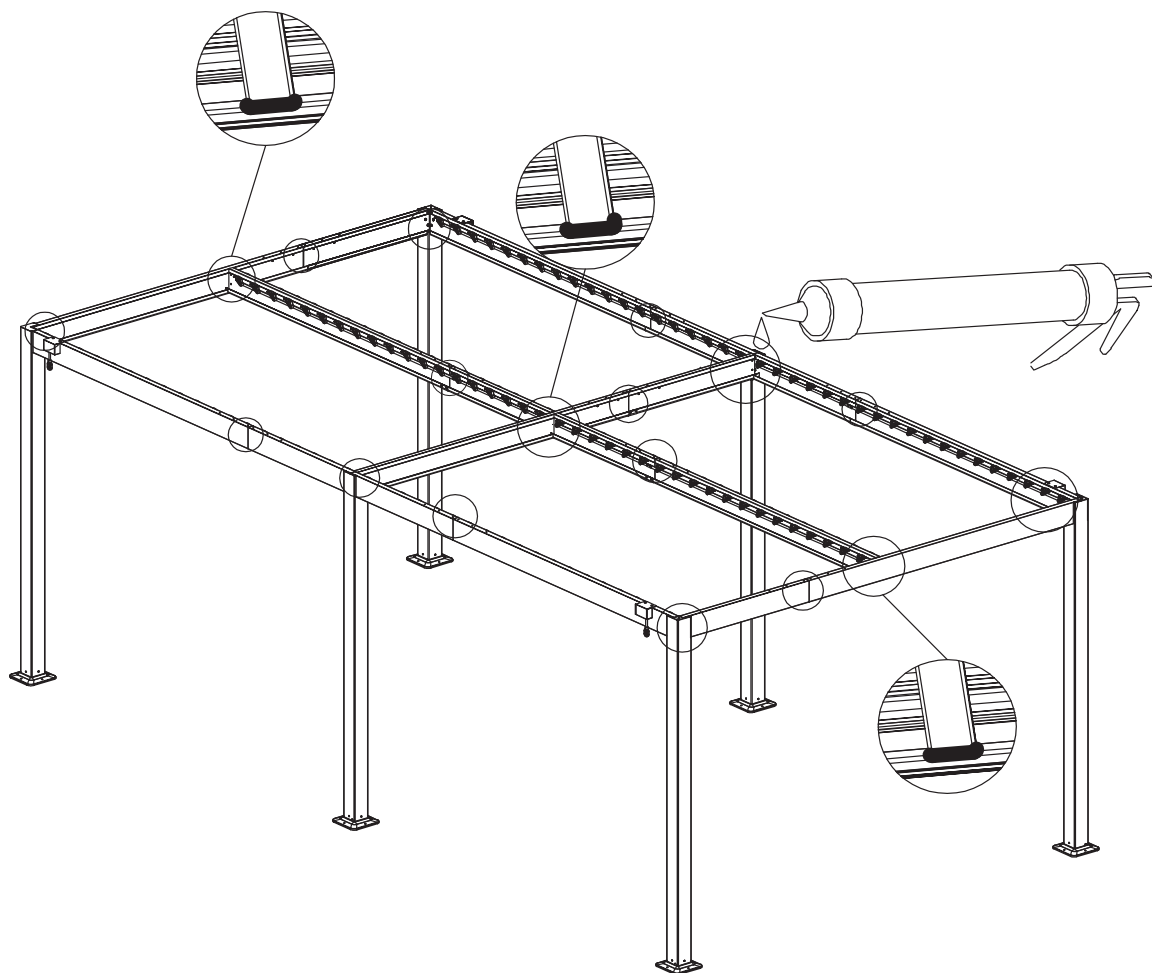

12



Z13 x16



Z5 x16

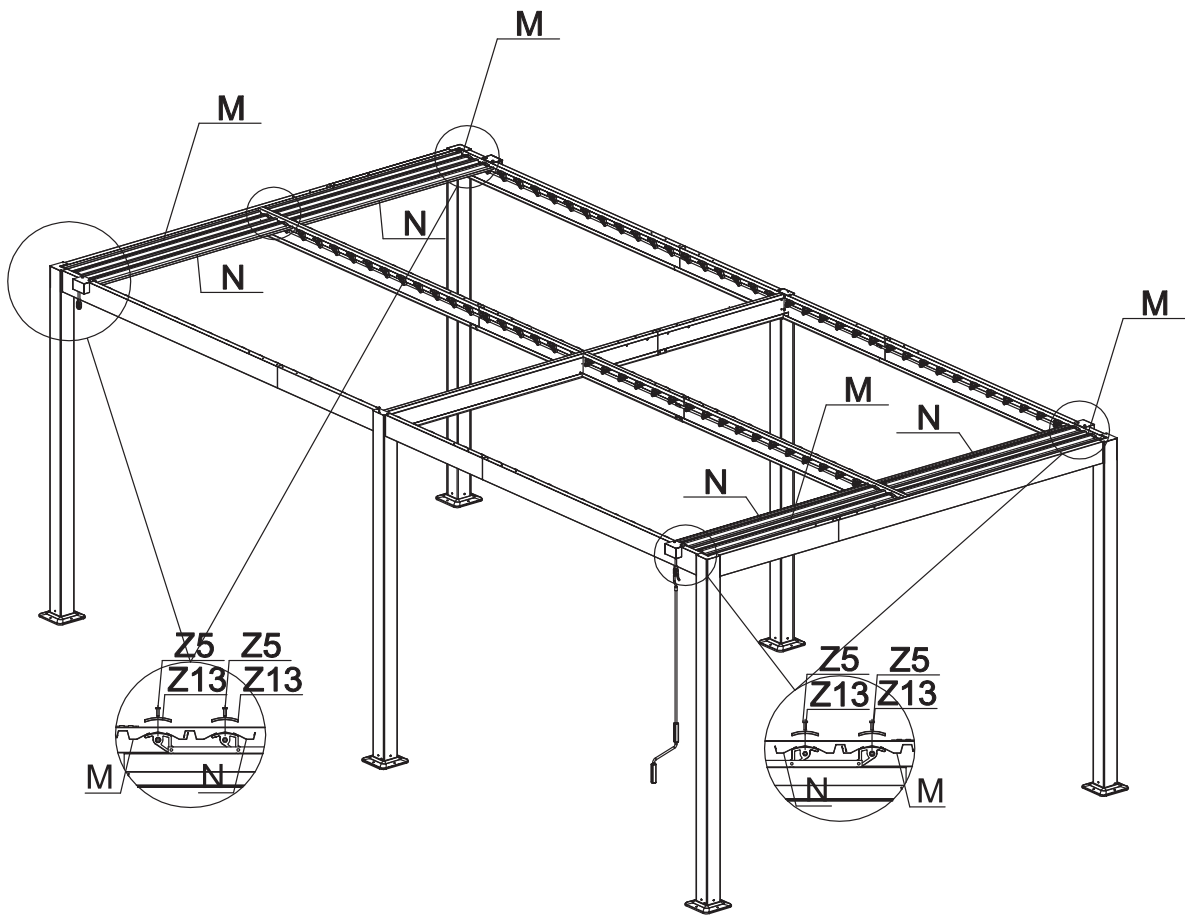

13



M x4

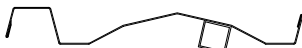

N x4





Z13 x16

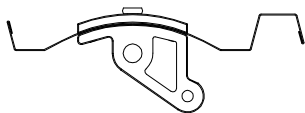
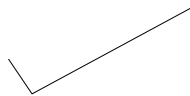
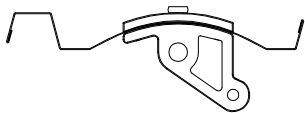
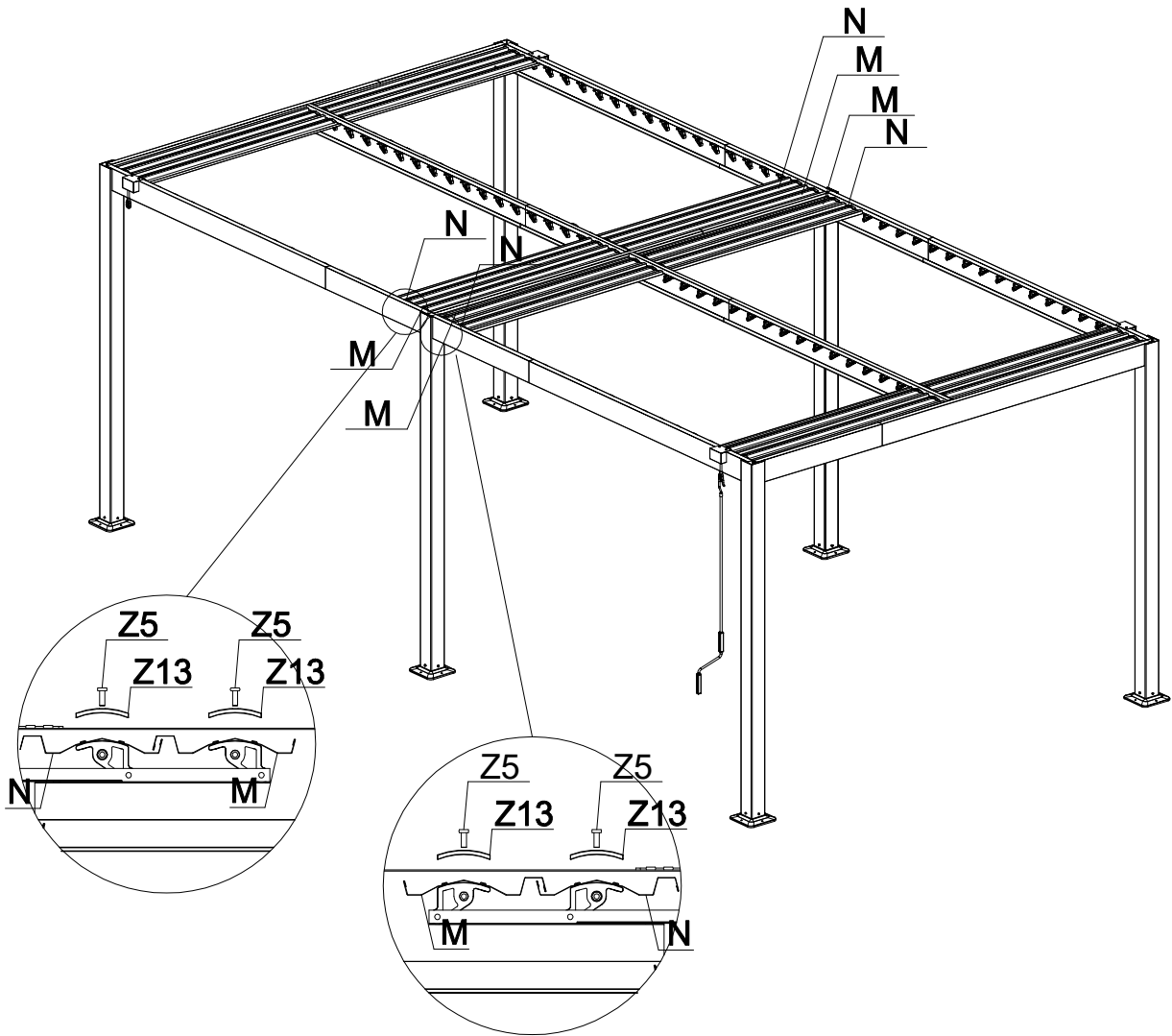

Z5 x16

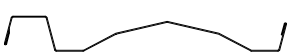

14	 M x48	 Z13 x96	 Z5 x96	
----	--	--	---	--

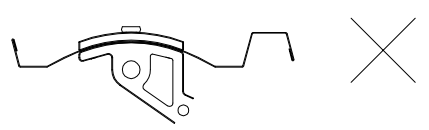
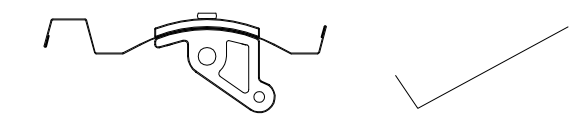
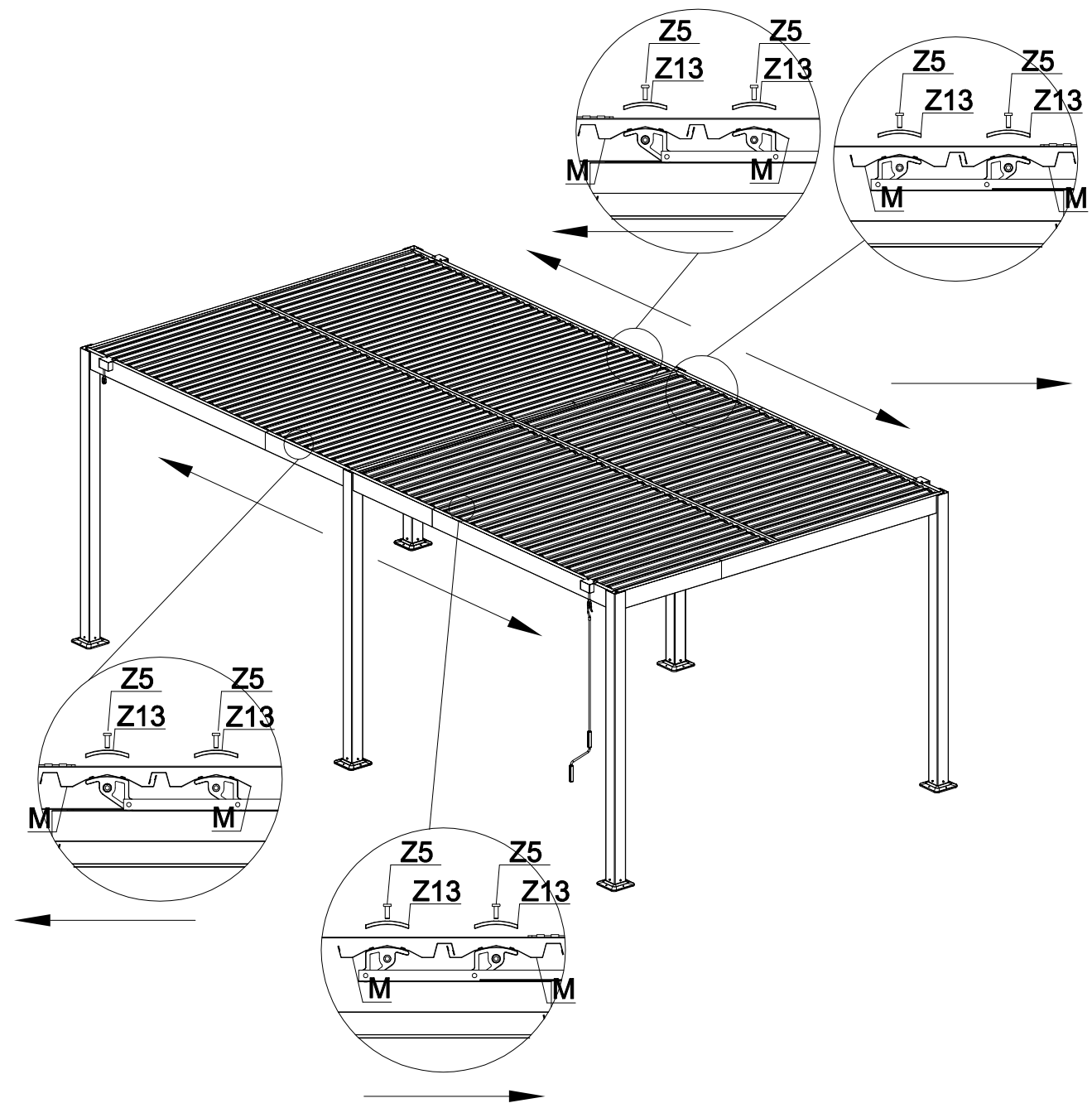

Responsable de la commercialisation du produit / Company in charge of commercializing the product / Responsable de la comercialización del producto / Responsabile della commercializzazione del prodotto:

GECODIS SA
32, rue de paradis
75010, Paris, France

Service commercial/ Commercial service/ Servicio comercial / Servizio commerciale :

Habitatetjardin.com
32, rue de paradis
75010, Paris, France
Assistance : +33 (0) 1 47 70 33 64

Service après-vente/ After sale services/ Servicio post-venta / Servizio dopo vendita:

GECODIS SA
32, rue de paradis
75010, Paris, France
<http://sav.habitatetjardin.com>

