

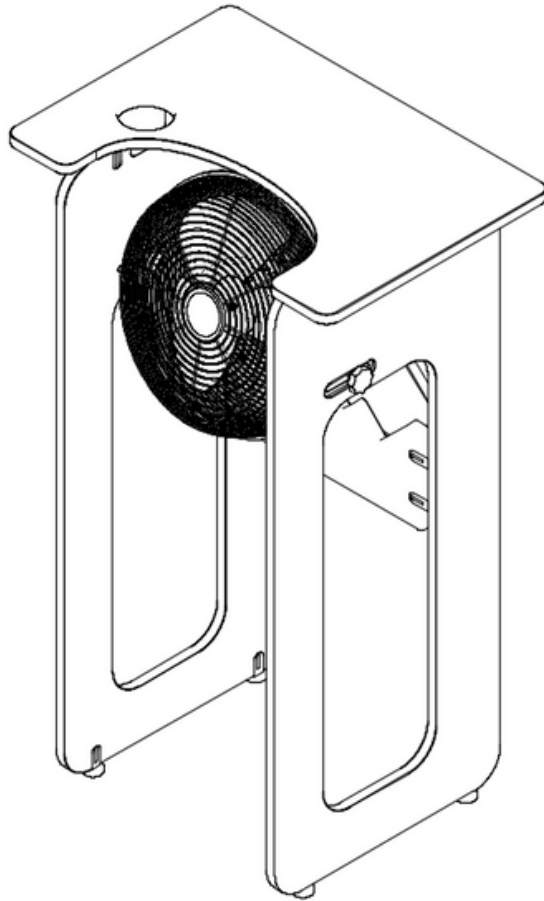

EXODRY.BIKE[®]
Ride Fresh - Ride Efficient



Exodry 1.0

14 kg / 31 lbs

100x60x42 cm

39x24x17 in

Maxi



15 kg

33 lbs



10 min





Nous vous remercions d'avoir choisi EXODRY.BIKE

Sachez que nous avons fait tout notre possible afin de vous apporter la meilleure expérience cela en tenant compte des enjeux sociétaux et environnementaux. Nous continuerons quand ce sera possible d'appliquer toutes mesures qui nous permettront de réduire encore davantage notre impact sur l'environnement. Le Saroo d'EXODRY.BIKE (hors appareil électrique) a été conçu, développé puis fabriqué et conditionné en France depuis la Bretagne. Ce produit a été emballé avec soin et en tenant compte de la réduction des déchets . Respectez bien les consignes de tri. Le montage s'effectue avec un seul outil de qualité qu'il faudra conserver. La plupart des pièces de montage sont déjà en place pour faciliter l'opération.

Nous espérons que vous trouverez entière satisfaction dans l'utilisation de nos produits afin que vous réalisiez des entraînements efficaces



Thank you for choosing EXODRY.BIKE

Please know that we have done our utmost to provide you with the best experience while taking into account societal and environmental issues. We will continue to apply all measures that will allow us to further reduce our impact on the environment. EXODRY.BIKE's Saroo (excluding the electrical device) was designed, developed, manufactured and packaged in France from Brittany. This product has been packaged with care and taking into account the reduction of waste. Please respect the sorting instructions. The assembly is carried out with a single quality tool that should be kept. Most of the assembly parts are already in place to facilitate the operation.

We hope that you will be satisfied with our products and that you will be able to carry out effective training sessions.

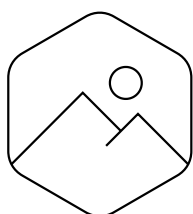

EXODRY.BIKE®
Ride Fresh - Ride Efficient

Saroo



vous permettra d'une part de maitriser votre température corporelle et d'autre part d'accueillir vos appareils multimédias pendant vos séances de Home Trainers. Vous trouverez ci-après la configuration type (1) pour utiliser Saroo.

(1) Saroo ne comprend pas les appareils multimédias, le bidon, le téléphone portable, le vélo et le home trainer.



will allow you to control your body temperature and to host your multimedia devices during your Home Trainers sessions. You will find below the typical configuration (1) for using Saroo.

(1) Saroo does not include multimedia devices, water bottle, mobile phone, bicycle and home trainer.



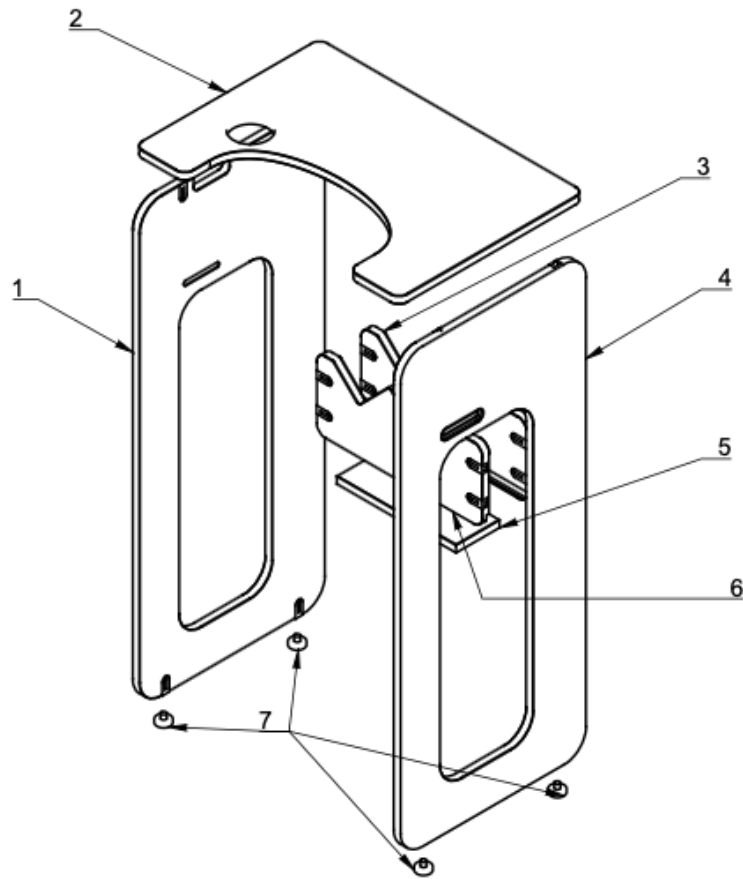

Merci pour votre confiance

Savoir vous accompagner efficacement lors de vos entraînements pour atteindre vos objectifs. Afin de bénéficier de la meilleure expérience, respectez les consignes de sécurité et apportez la plus grande attention à la notice d'utilisation.

Accédez à la notice d'utilisation en flashant ce QR-code ou via l'URL.

https://www.exodry.bike/pages/notice_d_utilisation



EXODRY.BIKE®
Ride Fresh - Ride Efficient

contact@exodry.bike



12-13

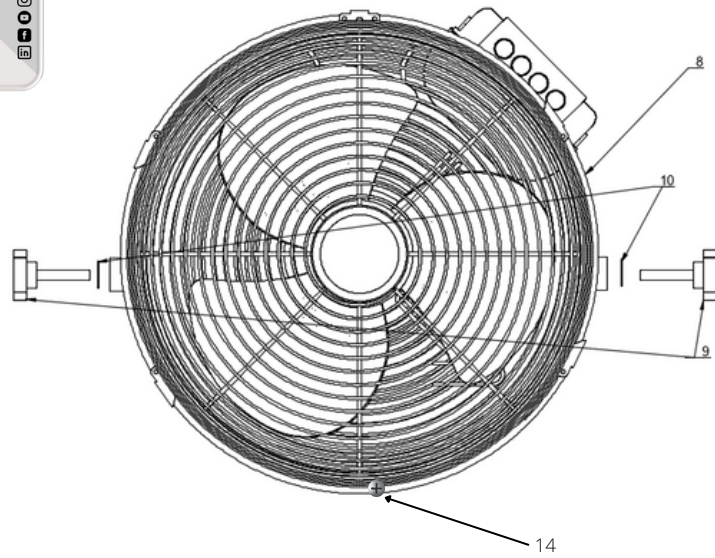

X4

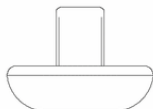

X16



Français

Liste des composants:

1. support gauche
2. tablette
3. partie arrière boîte connectiques
4. pied droit
5. fond de la boîte coulissant connectiques
6. partie avant boîte connectiques
7. vérins de nivellement réglage +/- 5mm
8. ventilateur
9. vis M8
10. rondelles M8
11. outil unique de montage
12. consignes de sécurité
13. manuel d'instructions
14. vis de sécurité

Signification des pictogrammes:

-  Dans la boîte
-  Nécessite une opération de tri
-  Assemblage
-  Utilisation
-  Nettoyage
-  Technicien habilité

Čeština

Přeloženo z francouzštiny

Seznam součástí:

1. levá podpora
2. police
3. konektorová skříňka zadního dílu
4. pravý stojan
5. dno konektorů posuvného boxu
6. přední část krabice pro připojení
7. nastavení nivelačních zvedáků
8. ventilátor
9. Šrouby M8
10. podložky M8
11. jednoduchý montážní nástroj
12. bezpečnostní pokyny
13. návod k použití
14. bezpečnostní šroub

Význam piktogramů:

-  V krabici
-  Vyžaduje třídění
-  Montáž
-  Použijte
-  Čištění
-  Kvalifikovaný technik

Dansk

Oversat fra fransk

Liste over komponenter:

1. venstre standplads
2. tablet
3. bageste del af stikdåse
4. højre standplads
5. bunden af kassen glidende stik
6. forreste del af forbindelsesboksen
7. justering af nivelleringsstifter
8. ventilator
9. M8-skruer
10. skiver M8
11. enkelt monteringsværktøj
12. sikkerhedsforskrifter
13. brugsanvisning
14. sikkerhedsskrue

Betydningen af piktogrammerne:

-  I kassen
-  Kræver en sorteringsoperation
-  Samling
-  Brug
-  Rengøring
-  Kvalificeret tekniker

Deutsch

Aus dem Französischen übersetzt

Liste der Komponenten:

1. linke Halterung
2. Tablet
3. Hinterer Teil Anschlussbox
4. Rechter Fuß
5. Boden der Box ausziehbar konnektoren
6. Vorderteil Konnektorenbox
7. Nivellierzylinder Einstellung
8. Lüfter
9. Schrauben M8
10. Unterlegscheiben M8
11. Einzigartiges Montagewerkzeug
12. Sicherheitshinweise
13. Bedienungsanleitung
14. Sicherheitsschraube

Bedeutung der Piktogramme:

-  In der Schachtel
-  Benötigt einen Sortiervorgang
-  Zusammenstellung
-  Zusammenstellung
-  Reinigung
-  Befähigter Techniker

English

Translated from French

List of components:

1. left-hand stand
2. tablet
3. rear part connector box
4. right stand
5. bottom of the box sliding connectors
6. front part of connectivity box
7. levelling jacks adjustment
8. fan
9. M8 screws
10. washers M8
11. single mounting tool
12. safety instructions
13. instruction manual
14. safety screw

Meaning of the pictograms:

-  Package contents
-  Requires sorting operation
-  Assembly
-  Use
-  Cleaning
-  Qualified technician

Español

Traducido del francés

Lista de componentes:

1. soporte izquierdo
2. estante
3. caja de conexiones de la parte trasera
4. soporte derecho
5. fondo de la caja conectores deslizantes
6. parte frontal de la caja de conectividad
7. ajuste de las clavijas de nivelación +/- 5mm
8. ventilador
9. Tornillos M8
10. arandelas M8
11. herramienta de montaje simple
12. instrucciones de seguridad
13. manual de instrucciones
14. tornillo de seguridad

Significado de los pictogramas:

-  En la caja
-  Requiere una operación de clasificación
-  Montaje
-  Utilice
-  Limpieza
-  Técnico cualificado

Italiano

Tradotto dal francese

Elenco dei componenti:

1. supporto di sinistra
2. tavoletta
3. parte posteriore scatola dei connettori
4. supporto destro
5. fondo della scatola connettori scorrevoli
6. parte anteriore del box di connettività
7. Regolazione dei martinetti di livellamento
8. ventilatore
9. Viti M8
10. rondelle M8
11. strumento di montaggio singolo
12. istruzioni di sicurezza
13. Manuale di istruzioni
14. vite di sicurezza

Significato dei pittogrammi:

-  Nella confezione
-  Richiede un'operazione di smistamento
-  Montaggio
-  Utilizzo
-  Pulizia
-  Tecnico qualificato

Magyar

Francia nyelvből fordítva

Az összetevők listája:

1. bal oldali állvány
2. tabletta
3. hátsó rész csatlakozódoboz
4. megfelelő állvány
5. a doboz alján csúsztató csatlakozók
6. a csatlakozó doboz elülső része
7. kiegyenlítő emelők beállítása
8. ventilátor
9. M8-as csavarok
10. M8-as alátétek
11. egyetlen szerelőszerszám
12. biztonsági utasítások
13. használati útmutató
14. biztonsági csavar

A piktogramok jelentése:

-  A dobozban
-  Válogatási műveletet igényel
-  Összeszerelés
-  Használja a címet.
-  Tisztítás
-  Képzett technikus

Nederlands

Vertaald uit het Frans

Lijst van onderdelen:

1. linkse stand
2. tablet
3. achterste deel aansluitdoos
4. juiste stand
5. bodem van de doos schuifverbindingen
6. voorste deel van connectiviteitsdoos
7. nivelleren van de vizels
8. ventilator
9. M8 schroeven
10. ringen M8
11. enkelvoudig montagegereedschap
12. veiligheidsinstructies
13. handleiding
14. veiligheidschroef

Betekenis van de pictogrammen:

-  In de doos
-  Vereist een sorteeroperatie
-  Montage
-  Gebruik
-  Schoonmaken
-  Gekwalificeerde technicus

Norsk

Oversatt fra fransk

Liste over komponenter:

1. venstre brakett
2. Tablett
3. koblingsboks bakre del
4. høyre fot
5. bunnen av koblingskryveboksen
6. koblingsboks foran
7. justering av nivelleringsjekk
8. fan
9. M8 skrue
10. M8 skiver
11. enkelt monteringsverktøy
12. sikkerhetsinstruksjoner
13. bruksanvisningen
14. sikkerhetsskrue

Betydningen av piktogrammene:

-  I boksen
-  Krever en sorteringsoperasjon
-  Montering
-  Bruk
-  Rengjøring
-  Autorisert tekniker

Polski

Tłumaczenie z języka francuskiego

Wykaz składników:

1. stojak lewy
2. tablet
3. skrzynka przyłączeniowa części tylnej
4. prawy stojak
5. dno skrzynki złącza przesuwne
6. przednia część skrzynki przyłączeniowej
7. regulacja dźwigników poziomujących
8. wentylator
9. Śruby M8
10. podkładki M8
11. pojedyncze narzędzie montażowe
12. instrukcje bezpieczeństwa
13. instrukcja
14. śruba zabezpieczająca

Znaczenie piktogramów:

-  W pudełku
-  Wymaga operacji sortowania
-  Montaż
-  Użyj
-  Czyszczenie
-  Wykwalifikowany technik







Português

Traduzido do francês

Lista de componentes:

1. esquerda
2. comprimido
3. caixa de ligação da parte traseira
4. posição direita
5. fundo da caixa conectores deslizantes
6. parte frontal da caixa de conectividade
7. ajuste de vales de nivelamento
8. ventilador
9. Parafusos M8
10. lavadoras M8
11. ferramenta de montagem única
12. instruções de segurança
13. manual de instruções
14. parafuso de segurança

Significado dos pictogramas:

-  Na caixa
-  Requer uma operação de triagem
-  Assembleia
-  Utilização
-  Limpeza
-  Técnico qualificado







Slovenčina

Prevedeno iz francoščine

Zoznam komponentov:

1. levo stojalo
2. tableta
3. priključna omarica zadnjega dela
4. desno stojalo
5. dno škatle drsni priključki
6. sprednji del škatle za priključke
7. nastavevte nivelirnih podstavkov
8. ventilator
9. Vijaki M8
10. podložke M8
11. eno orodje za montažo
12. varnostna navodila
13. navodila za uporabo
14. bezpečnostná skrutka

Význam piktogramov:

-  V krabici
-  Vyžaduje operáciu triedenia
-  Montáž
-  Použite
-  Čistenie
-  Kvalifikovaný technik

Suomi

Käännetty ranskasta

Luettelo komponenteista:

1. vasen jalusta
2. tabletti
3. takaosan liitäntäkotelo
4. oikea jalusta
5. laatikon pohjaan liukuliittimet
6. liitäntälaatikon etuosaa
7. tasausnostojen säätö
8. tuuletin
9. M8-ruuvit
10. aluslevyt M8
11. yksittäinen asennustyökalu
12. turvallisuusohjeet
13. käyttöohjeet
14. turvaruuvi

Piktogrammien merkitys:

-  Laatikossa
-  Vaatii lajittelemisn
-  Kokoonpano
-  Käyttää
-  Puhdistus
-  Valtuutettu teknikko

Svenska

Översatt från franska

Förteckning över komponenter:

1. vänsterstället
2. tablett
3. bakre delen anslutningslåda
4. rätt ställning
5. botten av lådan glidande kontakter
6. främre delen av anslutningsboxen
7. Justering av utjämningsdonen
8. fläkt
9. M8-skrivar
10. brickor M8
11. verktyg för enkelmontering
12. säkerhetsanvisningar
13. bruksanvisning
14. säkerhetsskruv

Betydelsen av piktogrammen:

-  I boksen
-  Kräver en sortering
-  Montering
-  Använd
-  Rengöring
-  TKvalificerad tekniker

Garantie/Warranty



Ce produit est garanti pendant une durée de 24 mois à compter de la date d'achat initiale effectué par le consommateur, contre tout défaut de fabrication, sur présentation de la preuve d'achat (ticket de caisse avec date, lieu d'achat, nom du produit).

Pendant la durée de garantie contractuelle, le produit défectueux devra être retourné dans son emballage d'origine auprès du service après-vente du revendeur ou du site Internet, selon le lieu d'achat. Après inspection du produit, le service après-vente procédera à la réparation ou au remplacement de la pièce ou du produit défectueux si le produit a été utilisé correctement, à l'exclusion de tout autre dédommagement



This product is guaranteed for a period of 24 months from the date of initial purchase by the consumer, against any manufacturing defect, upon presentation of the proof of purchase (receipt with date, place of purchase, name of the product).

During the contractual warranty period, the defective product must be returned in its original packaging to the dealer's after-sales service or to the website, depending on the place of purchase. After inspection of the product, the after-sales service will repair or replace the defective part or product if the product has been used correctly, to the exclusion of any other compensation

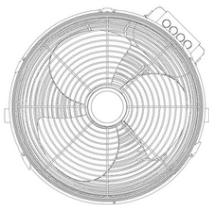
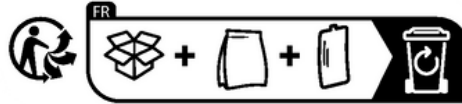

<https://www.ecosystem.eco>

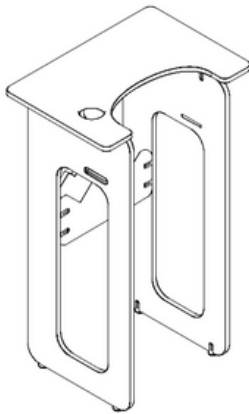

<https://quefairedemesdechets.fr>

Merci pour votre confiance

Sans vous accompagner efficacement lors de vos entraînements pour atteindre vos objectifs. Afin de bénéficier de la meilleure expérience, respectez les consignes de sécurité et apportez la plus grande attention à la notice d'utilisation.

Accédez à la notice d'utilisation en flashant ce QR-code ou via l'URL.

https://www.exodry.bike/pages/notice_d_utilisation



EXODRY.BIKE
Ride Fresh - Ride Efficient

contact@exodry.bike



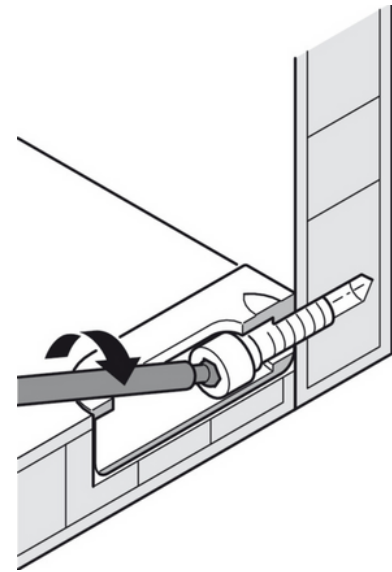
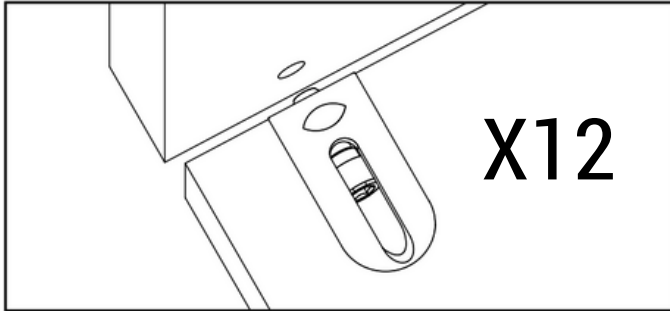

Start

X16



1

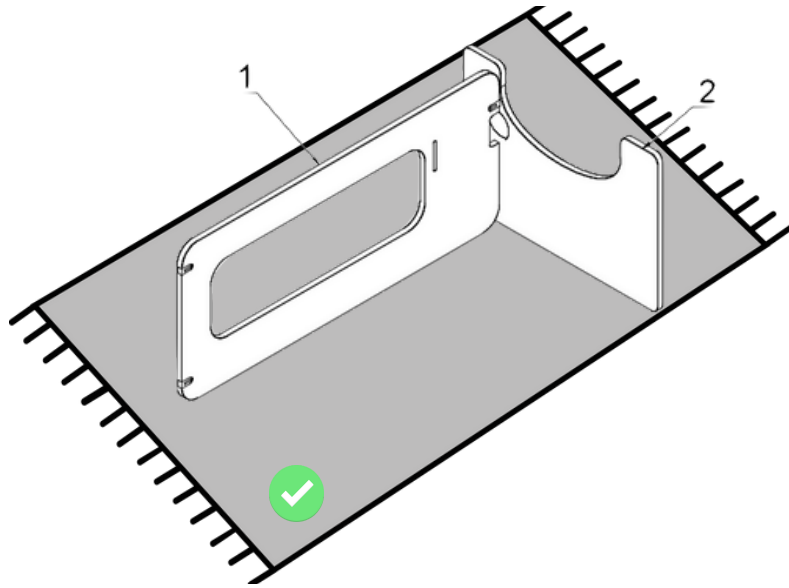

2

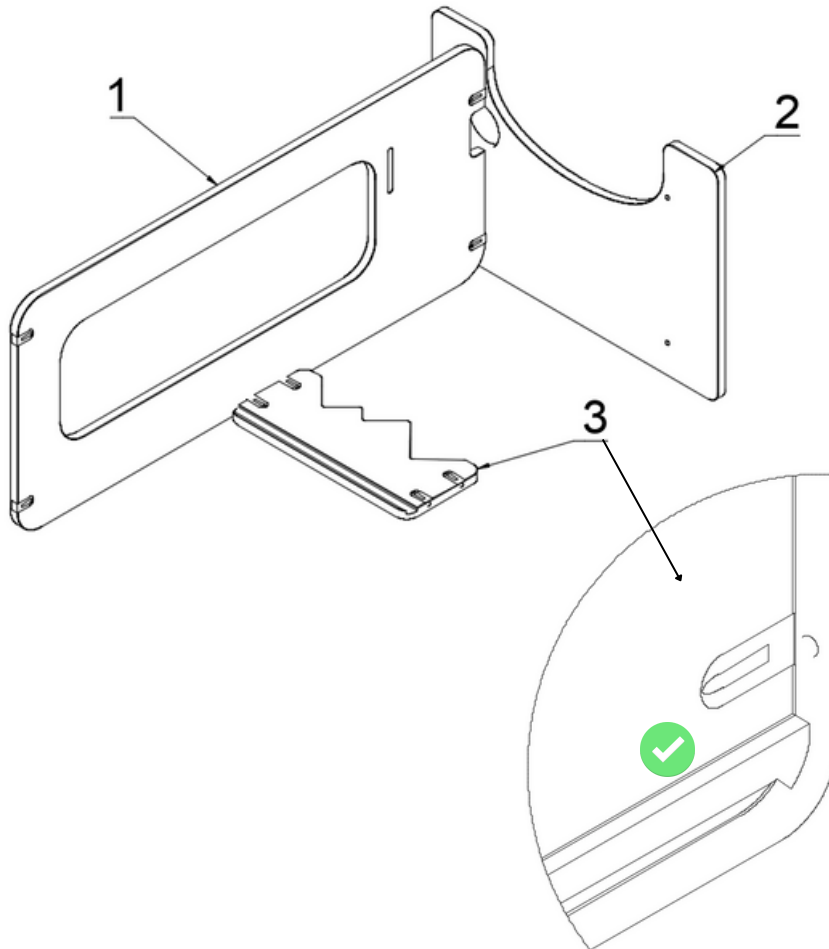

3

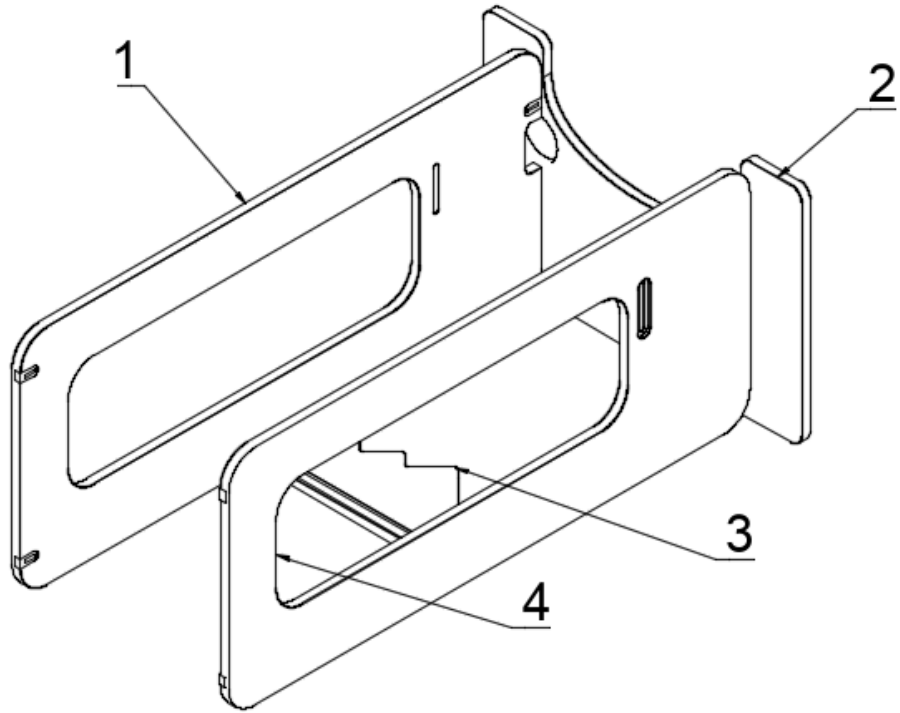

4

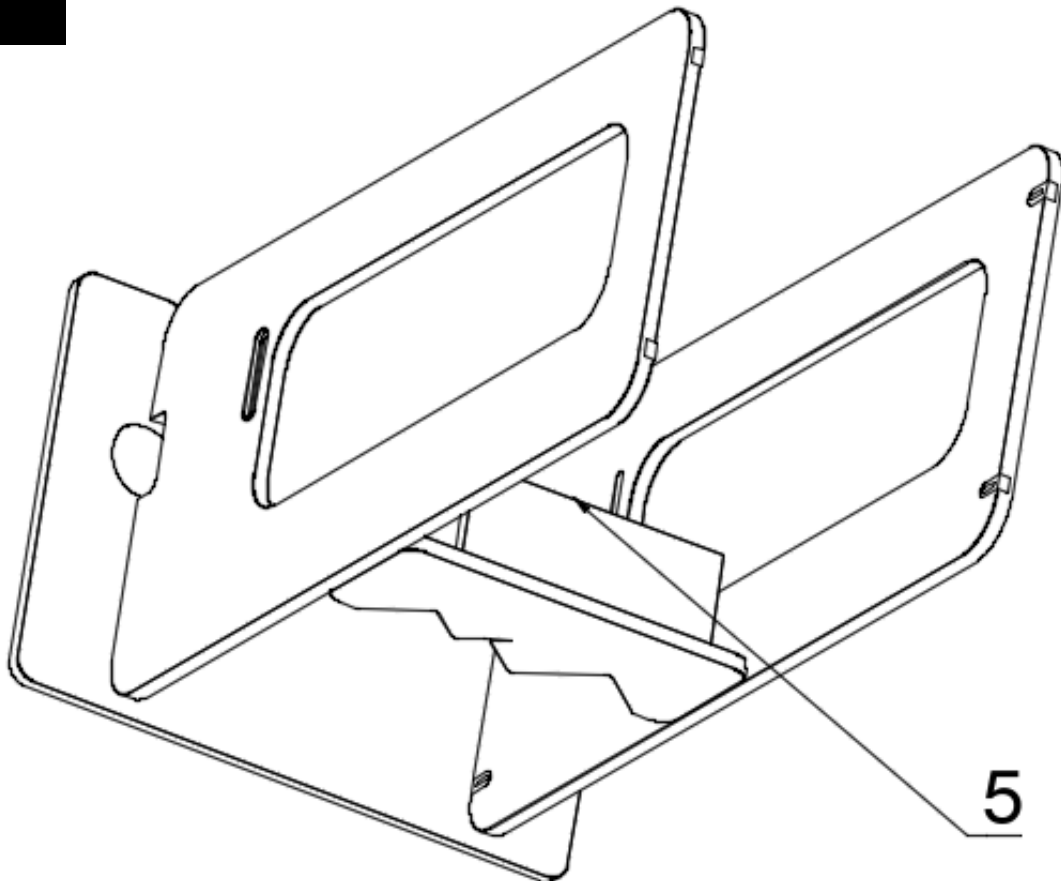

5

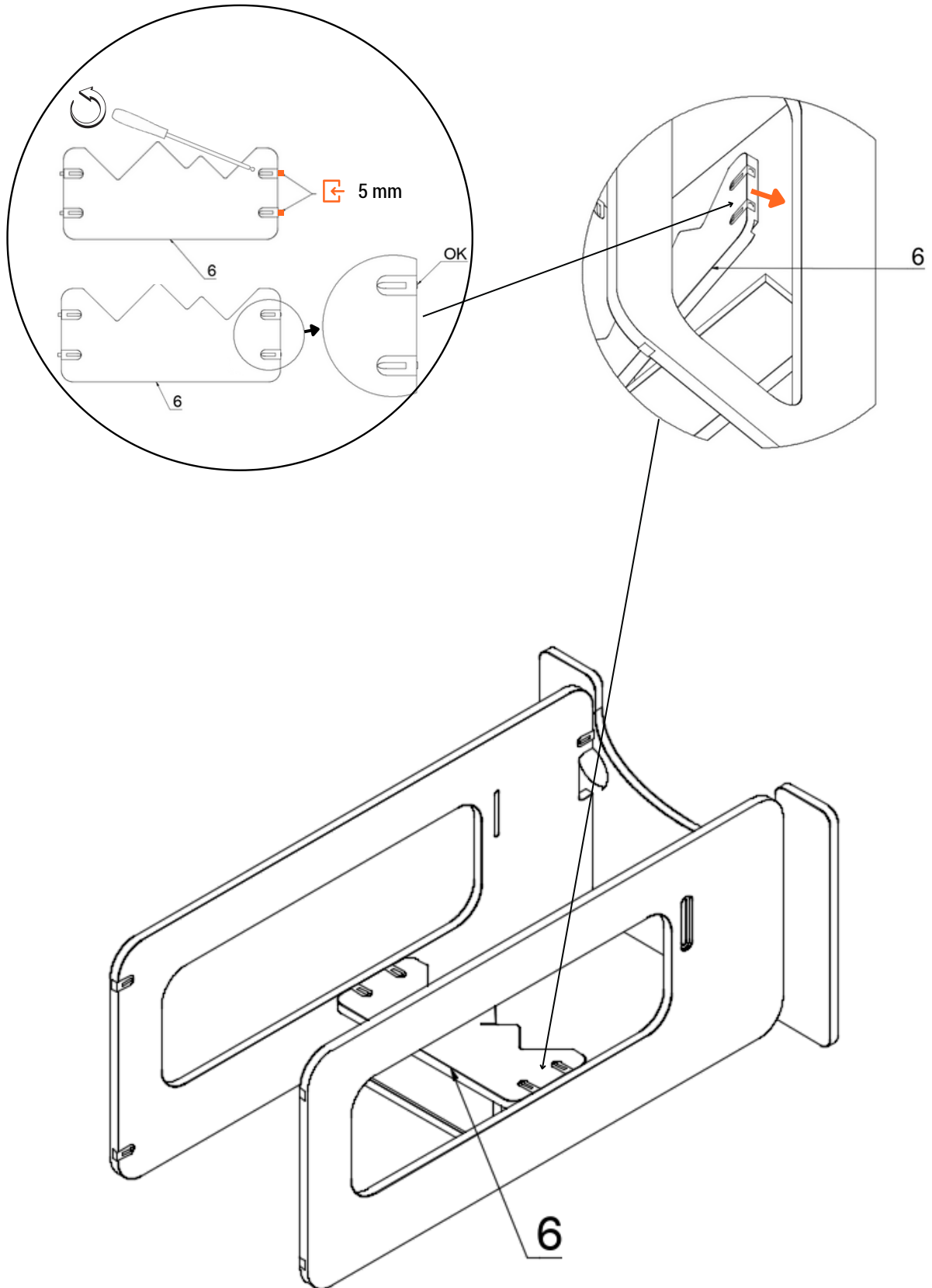

6

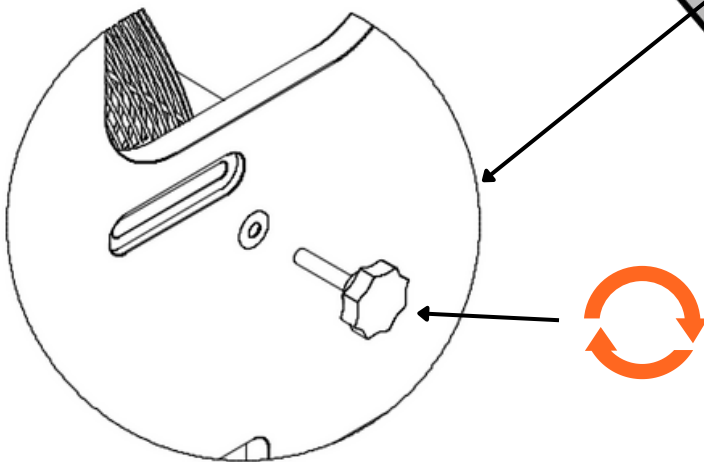
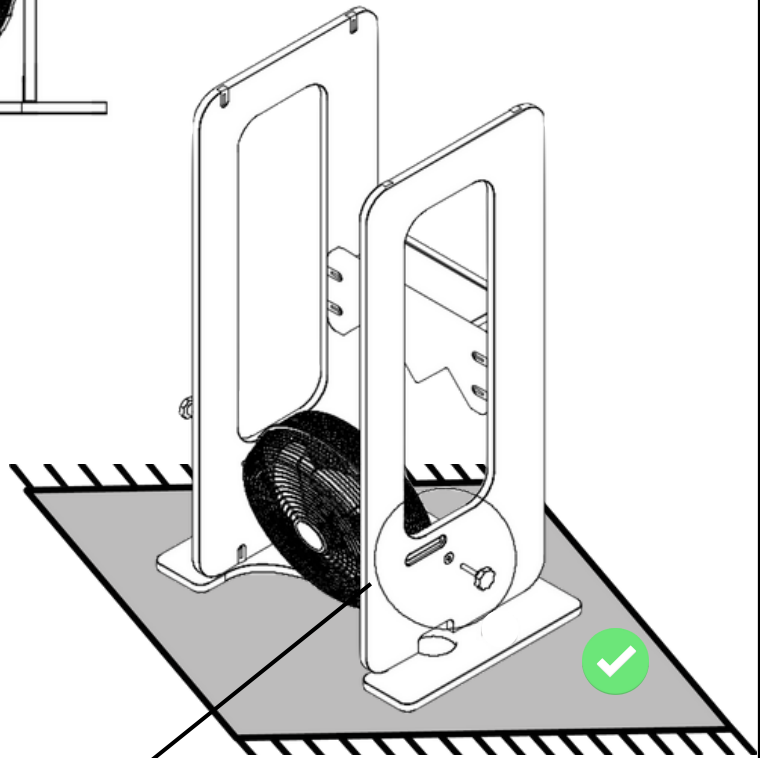
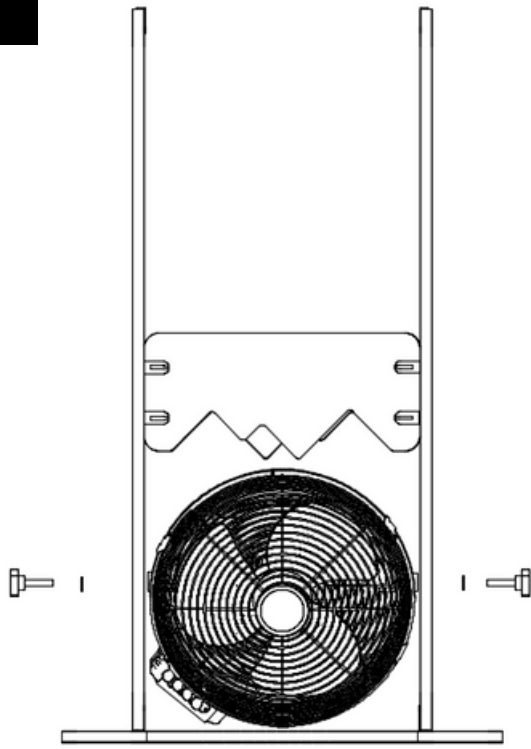

7

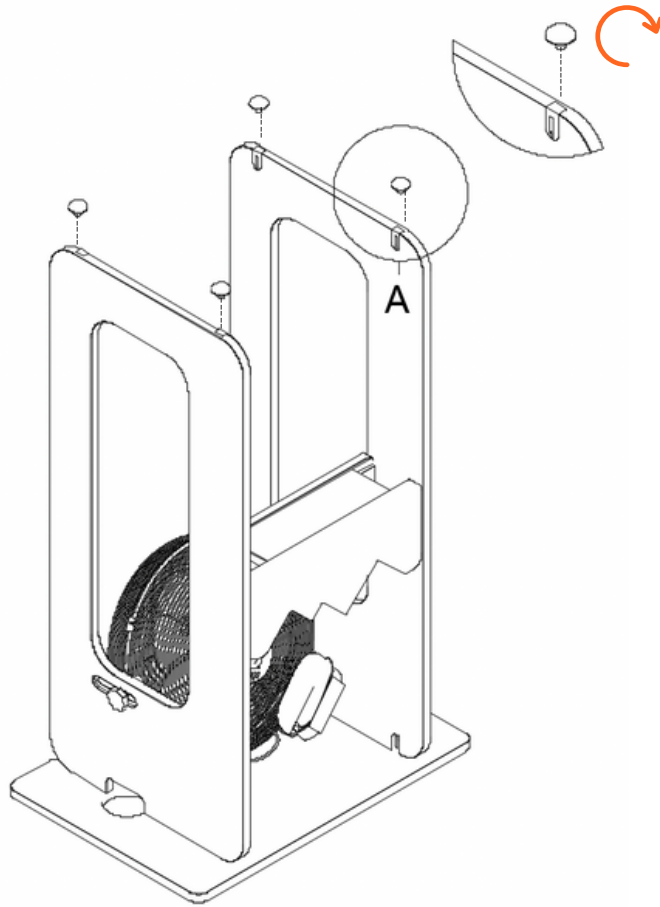

8

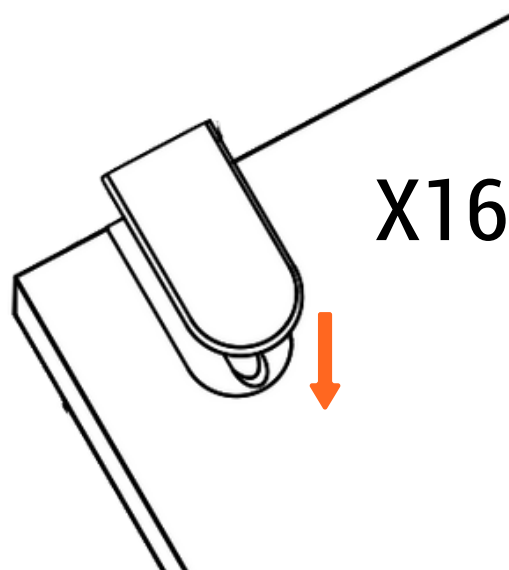

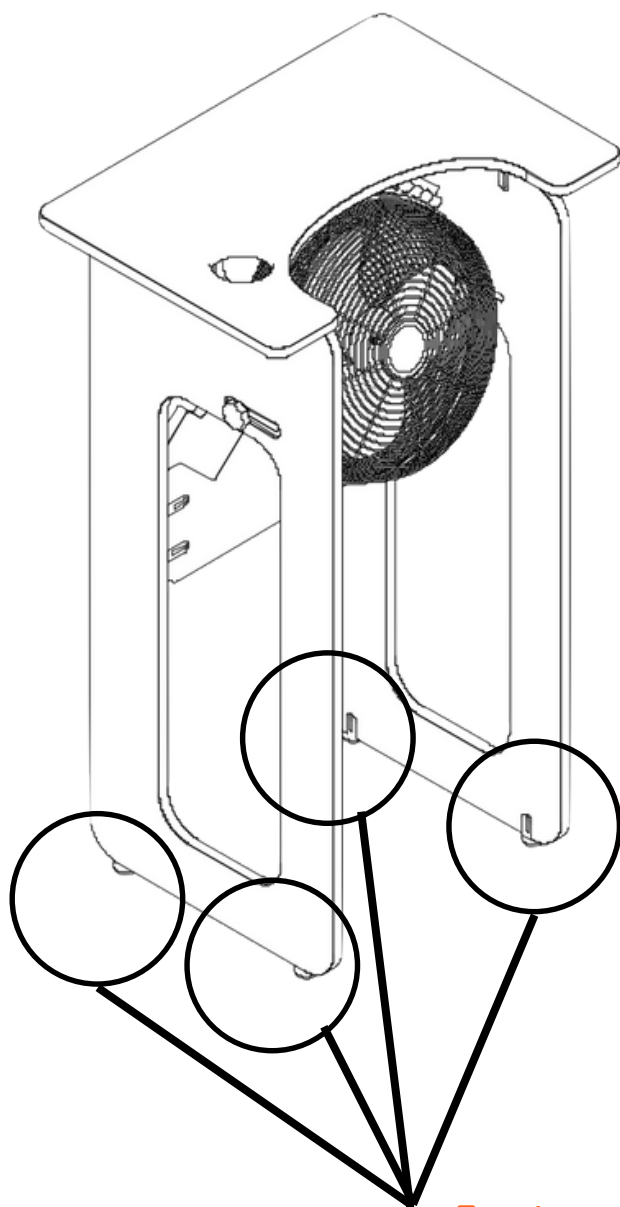
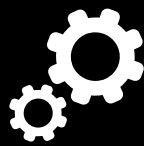

↓ ↑ 5 mm max

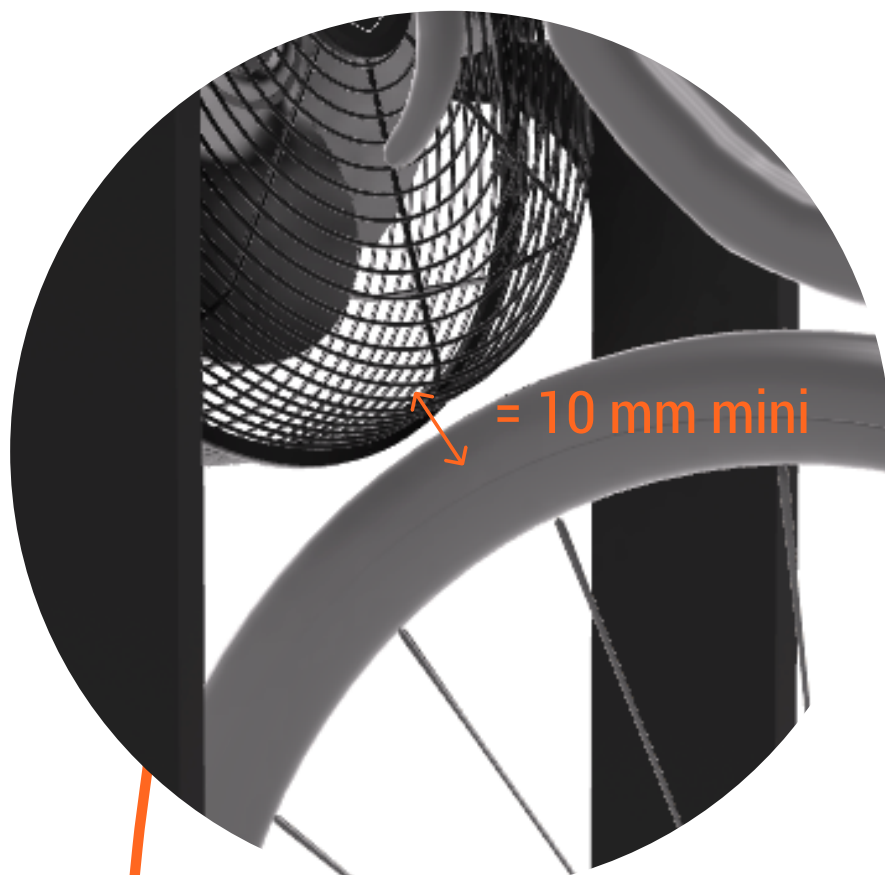
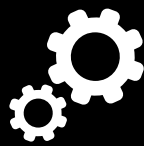

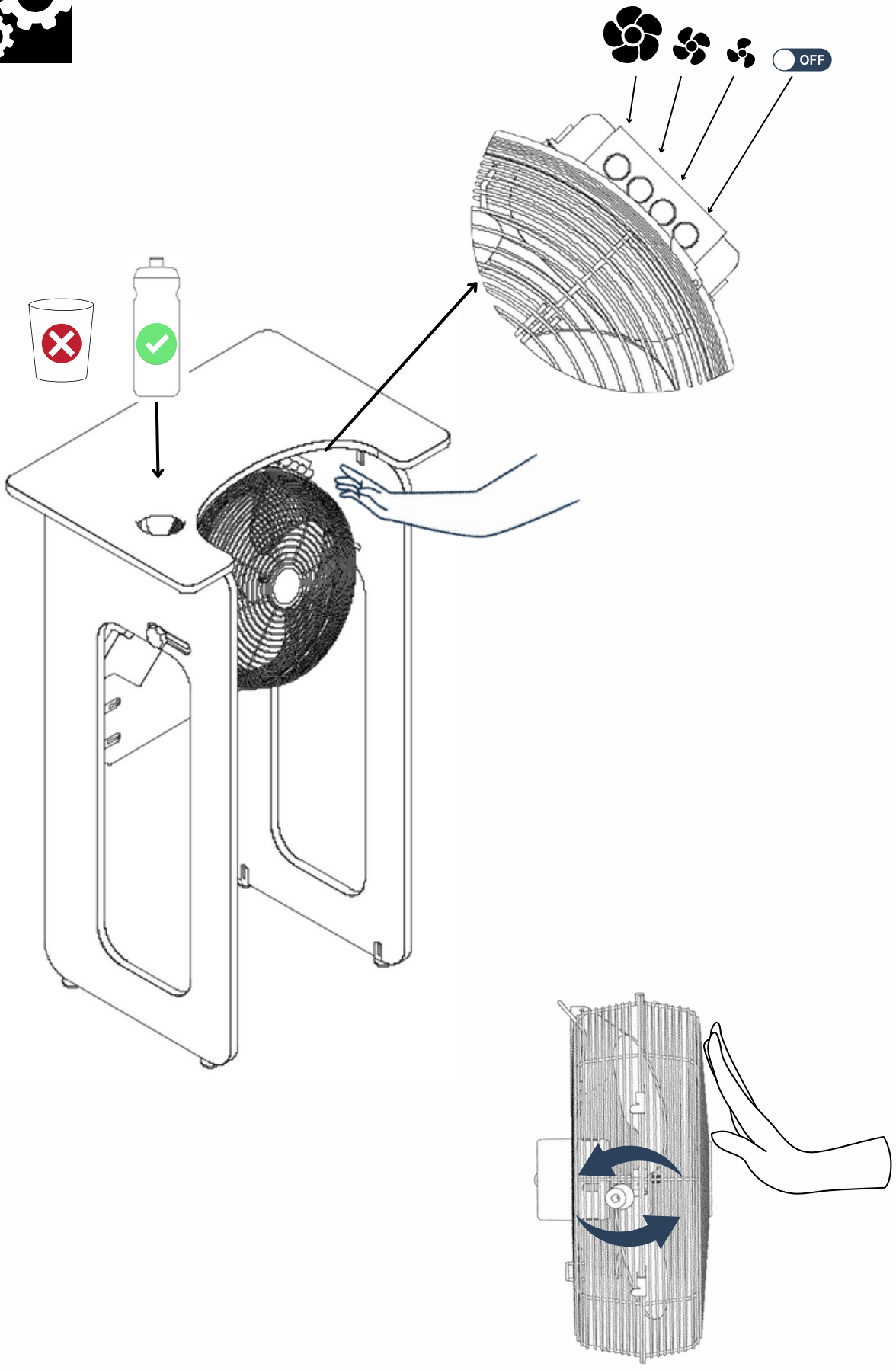
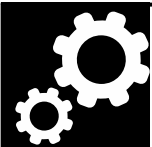

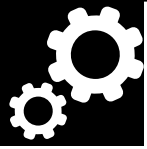

START

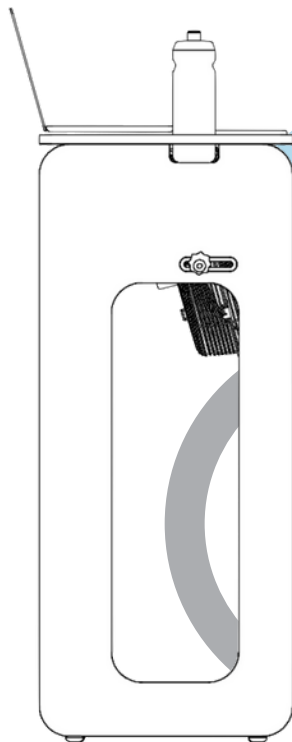
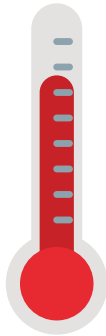
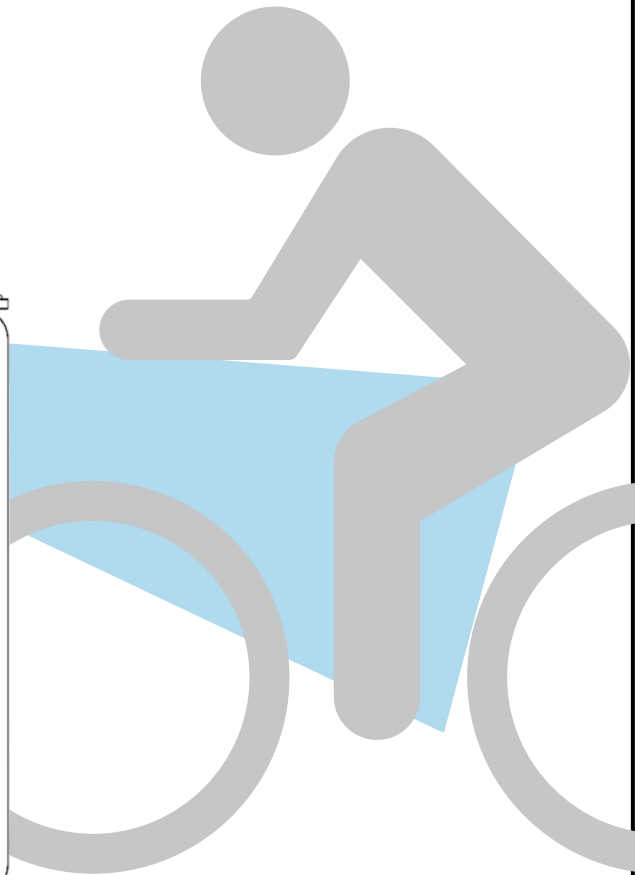
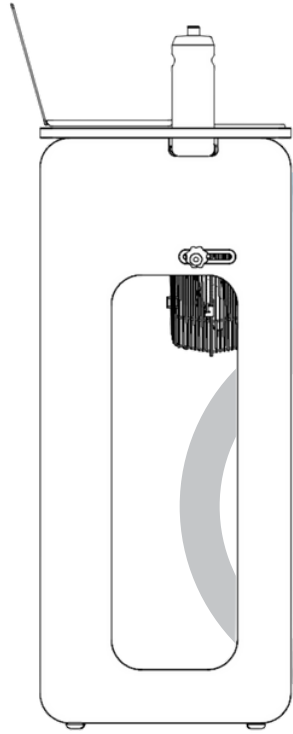
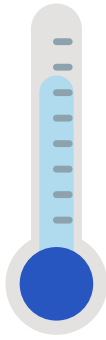

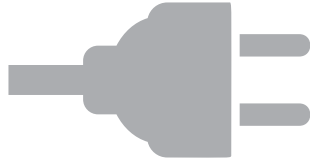

1

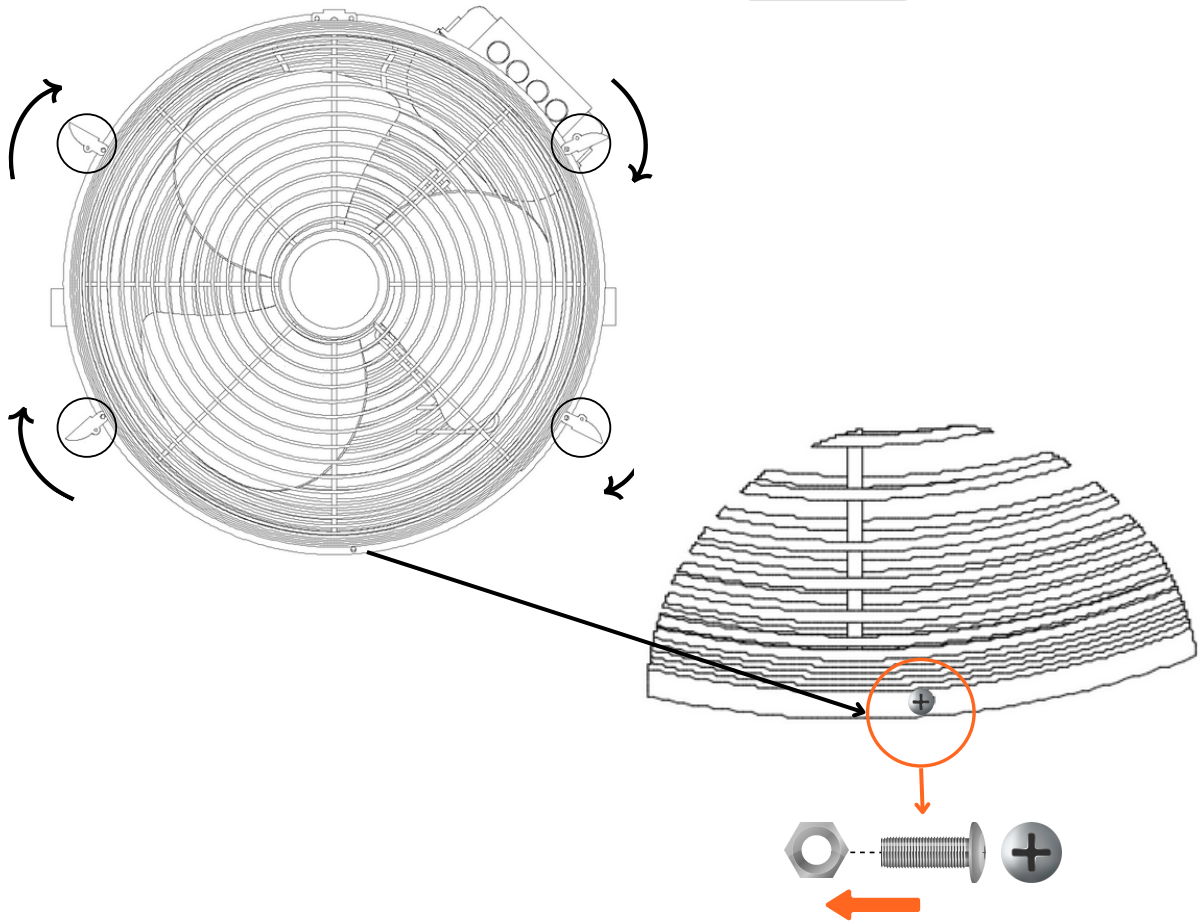

2

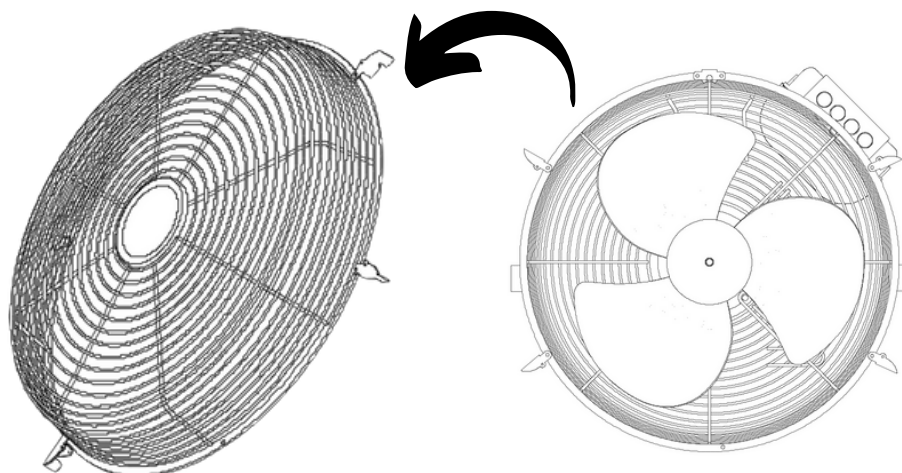

3

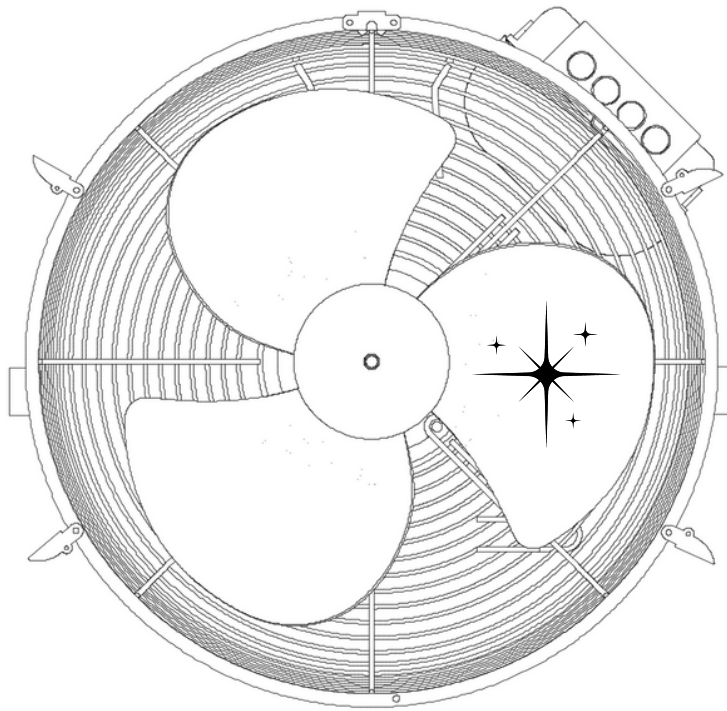

4

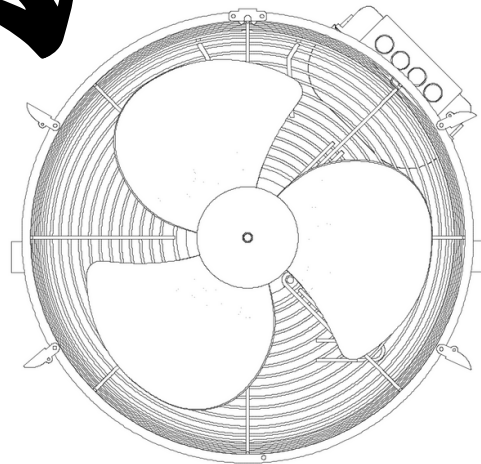
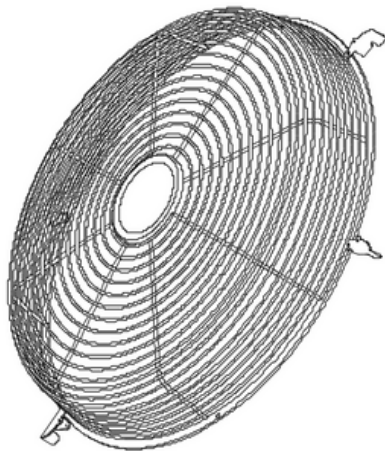

6

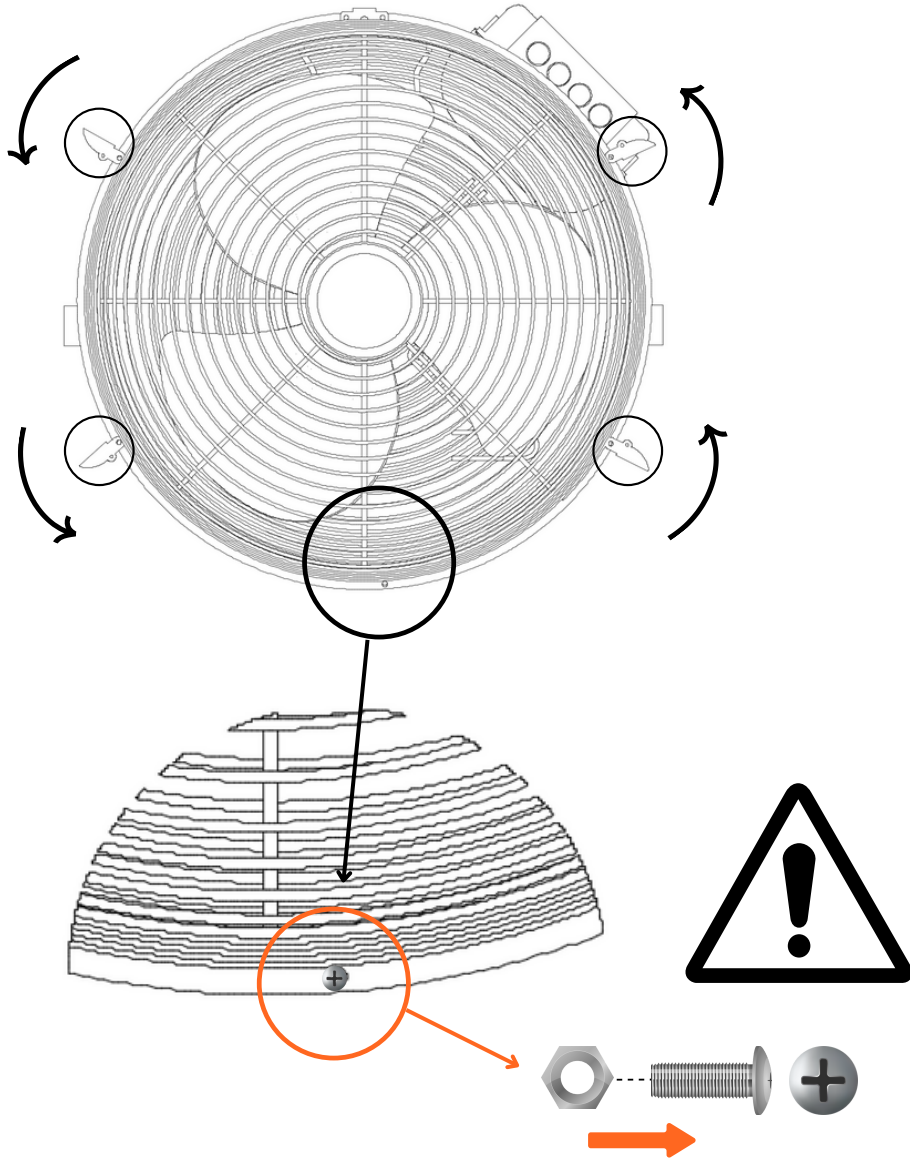

7

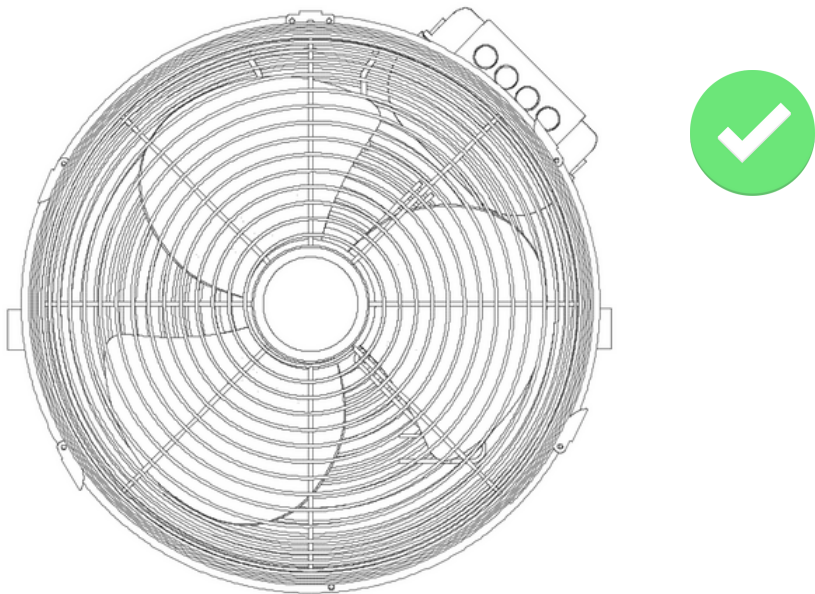

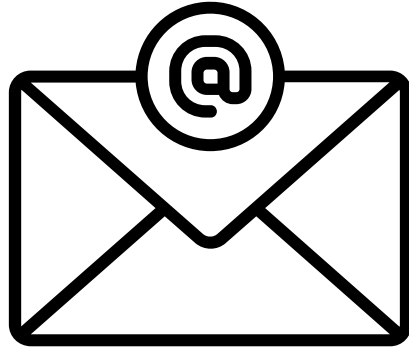

contact@exodry.bike

Caractéristiques techniques

Désignation		EXODRY® 1.0
Raccordement électrique	V	220-240
Puissance absorbée	W	55
Fréquence	Hz	50
Nombre de vitesses		3
Poids	Kg	14
Dimensions (h x l x p)	mm	980 x 407/600 x 420

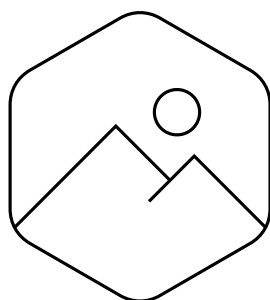
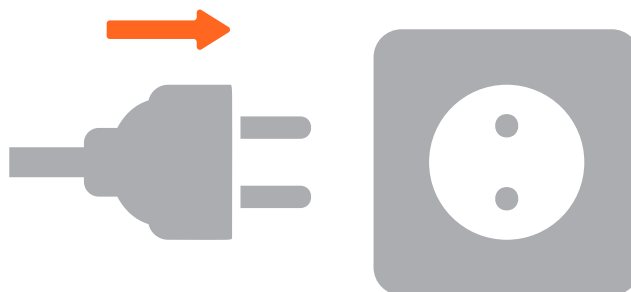

EXODRY.BIKE®
Ride Fresh - Ride Efficient