

TOM 375996

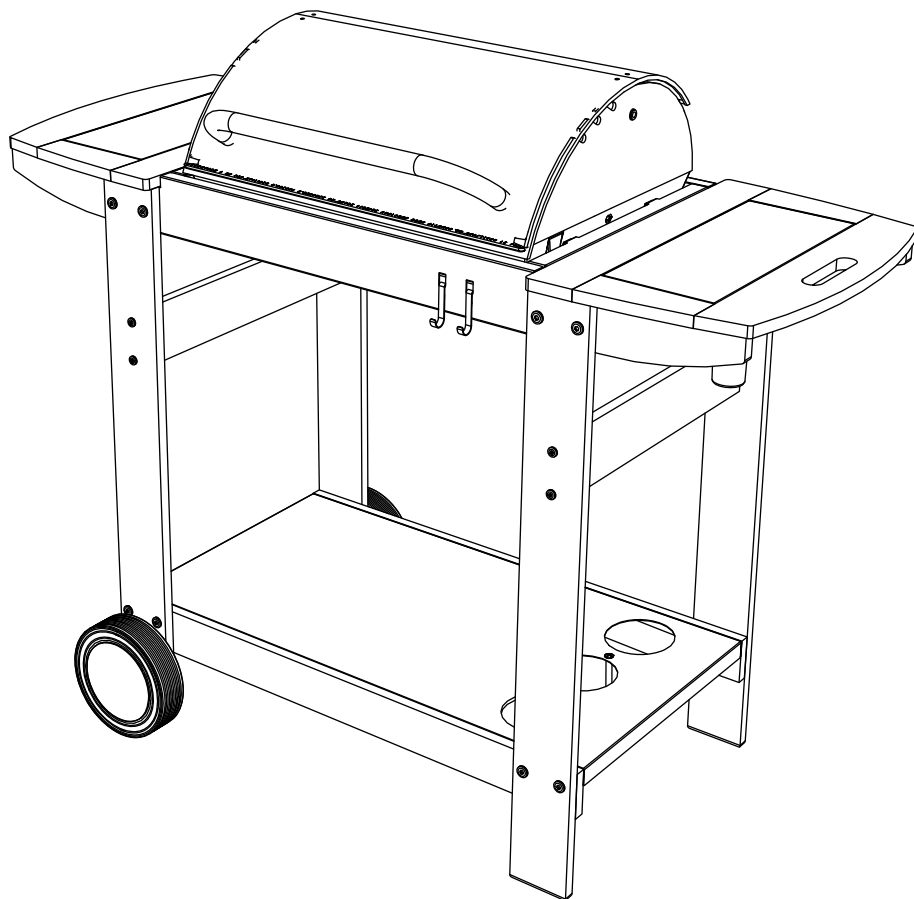

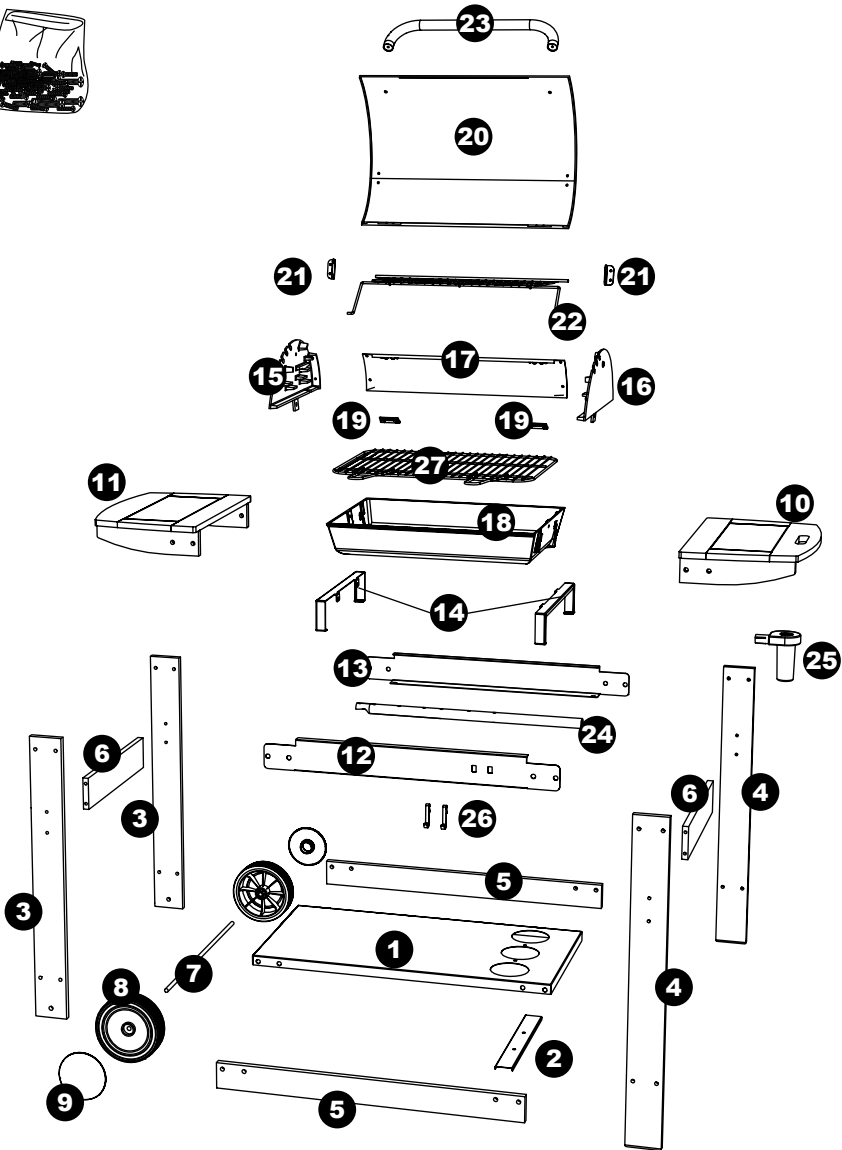







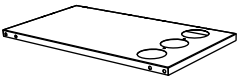
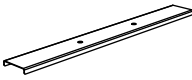
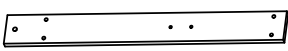
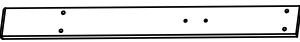

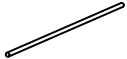

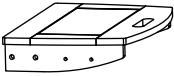
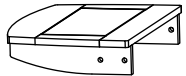

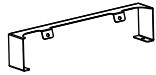





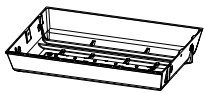

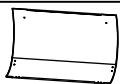
	8 x 55	2
	8 x 25	16
	6 x 65	2
	6 x 45	8
	6 x 40	1
	6 x 20	5

	6 x 16	4
	6 x 10	4
	4 x 12	16
	Ø6	2
	Ø4	12

	Ø8	16
	Ø10	2
	Ø6	14
	Ø4	16
	5	2
	4	1

1		x 1
2		x 1
3		x 2
4		x 2
5		x 2
6		x 2
7		x 1
8		x 2
9		x 2
10		x 1
11		x 1
12		x 1
13		x 1
14		x 2

15		x 1
16		x 1
17		x 1
18		x 1
19		x 2
20	 Couvercle de protection	x 1
21		x 2
22		x 1
23		x 1
24		x 1
25		x 1
26		x 2
27		x 1
28		x 1

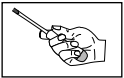
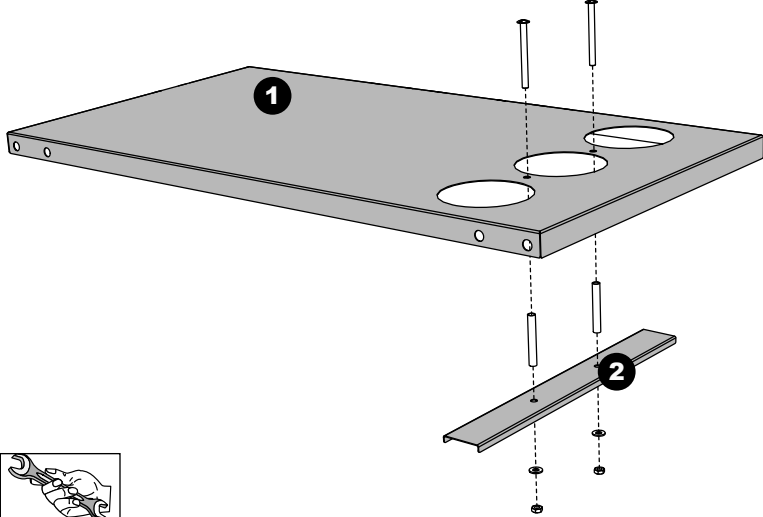
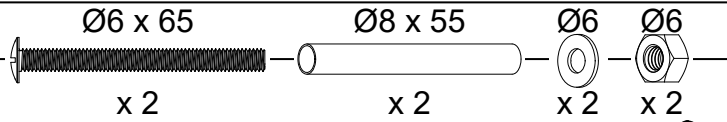
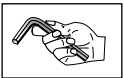
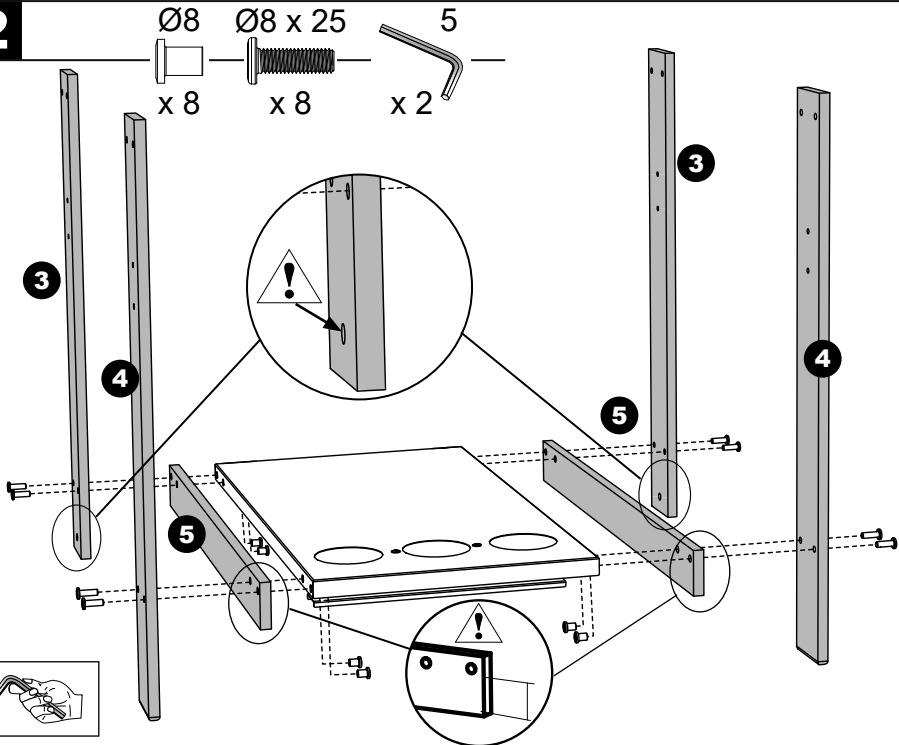
1**2**

3

Ø6 x 45

Ø 10

x 8

x 2

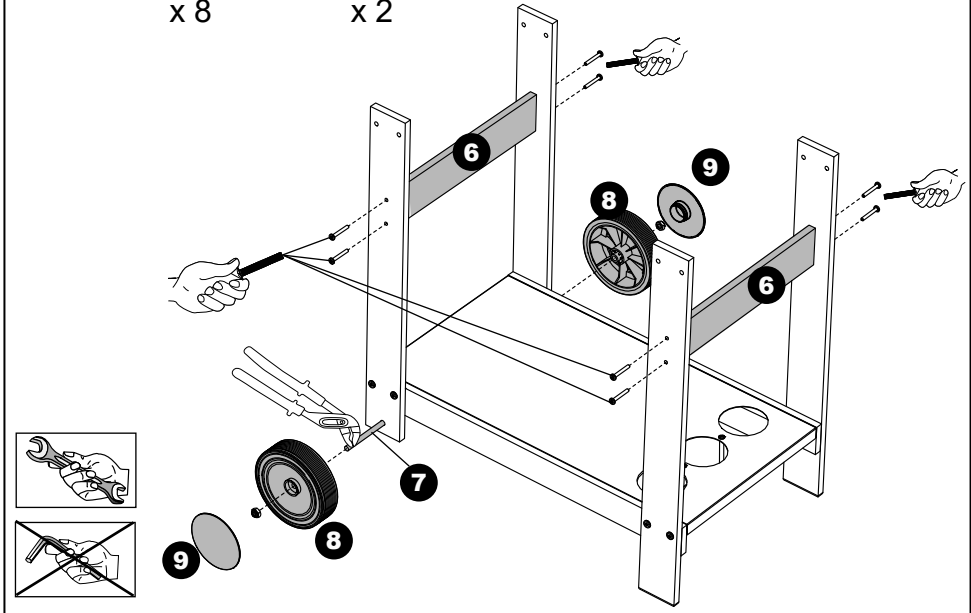
**4**

Ø8

Ø8 x 25

x 8

x 8

5

4

x 2

x 1

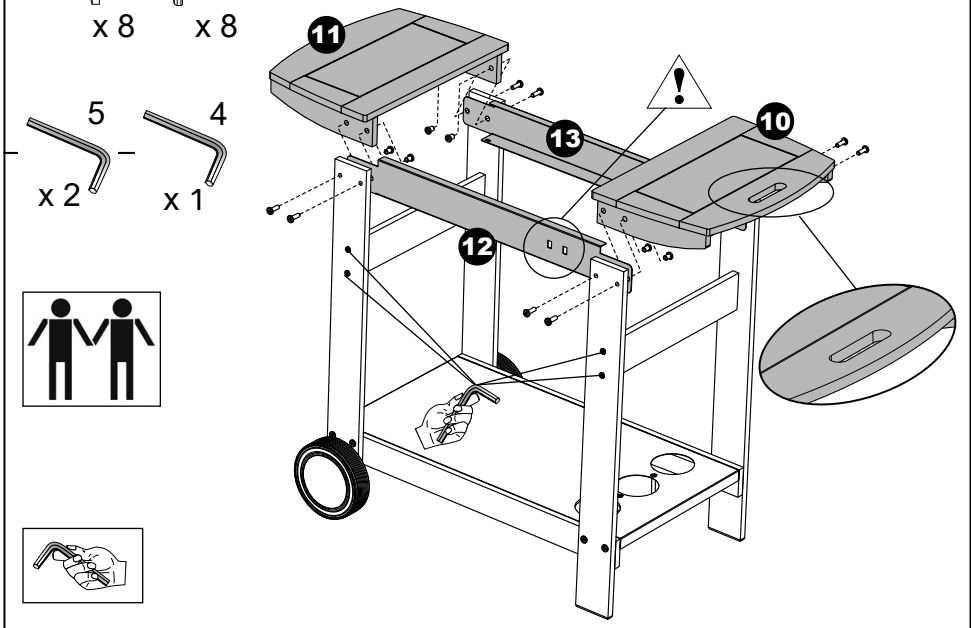

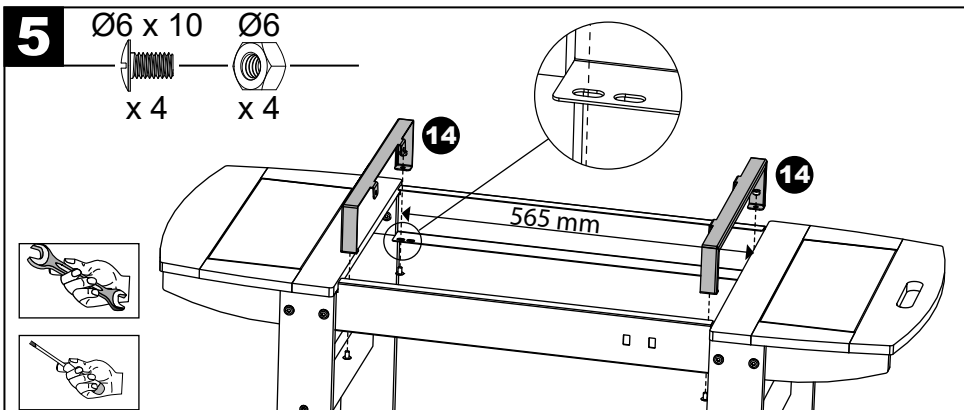

FR - ATTENTION

Le bois peut travailler après quelques jours de montage, vérifier et resserrer toutes les vis de votre chariot bois.

ES - ATENCIÓN

La madera puede desajustarse después de algunos días, compruebe y reapriete todos los tornillos de su carrito de madera.

PT - ATENÇÃO

O volume da madeira pode variar após alguns dias de montagem. verifique e volte a apertar todos os parafusos do seu carro de madeira.

IT - ATTENZIONE

Il legno può imbarcarsi dopo qualche giorno dal montaggio. verificare e restringere tutte le viti del carrello in legno.

PL - LET OP

W ciągu kilku dni po montażu, drewniane elementy grilla mogą ulec właściwemu dla drewna - niewielkiemu odkształceniu, prosimy sprawdzić i dokręcić wszystkie śrubki mocujące drewno w naszym grillu.

EN - WARNING

The wood may continue to change several days after assembly ; so check and tighten all the screws of your wooden chariot.

NL - LET OP

Enkele dagen na de montage kan het hout gaan werken ; controleer daarom alle schroeven van uw houten kar en draai deze vast.

DE - ACHTUNG

Holz arbeitet. aus diesem Grund kann es durchaus vorkommen, dass sich das Holz einige Tage nach Zusammenbau des Holzkarrens verzieht. überprüfen und ziehen sie daher sämtliche schrauben nach.

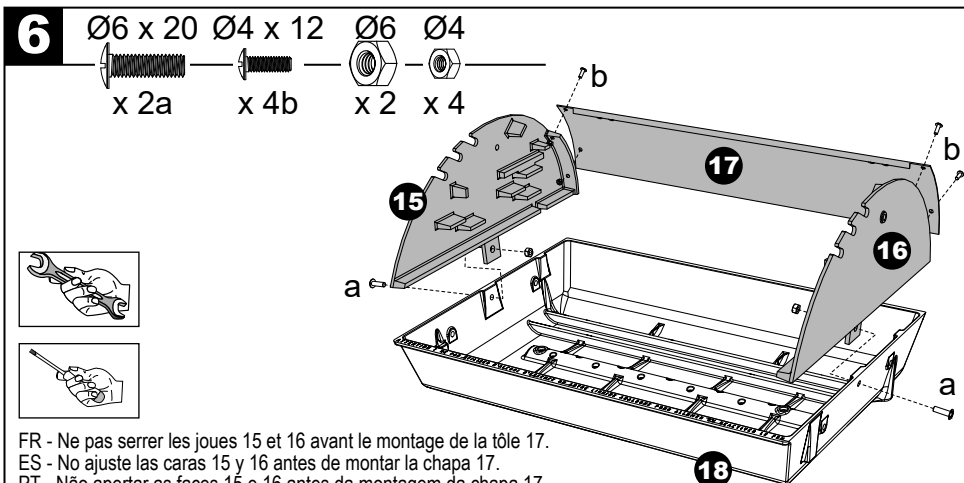

FR - Ne pas serrer les joues 15 et 16 avant le montage de la tôle 17.

ES - No ajuste las caras 15 y 16 antes de montar la chapa 17.

PT - Não apertar as faces 15 e 16 antes da montagem da chapa 17.

IT - Non avvitare le ghiera 15 e 16 prima di aver montato la lamiera 17.

PL - Nie skręcać boków 15 i 16 przed montażem blachy 17.

EN - Never tighten sides 15 and 16 before assembling panel 17.

NL - Zet de zijvleugels 15 en 16 pas vast , nadat het achterpaneel 17 gemonteerd is.

DE - Die beiden Seitenteile 15 und 16 erst nach Anbringen der Rückwand 17.

7

Ø6 x 16



x 4

Ø6

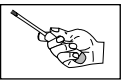
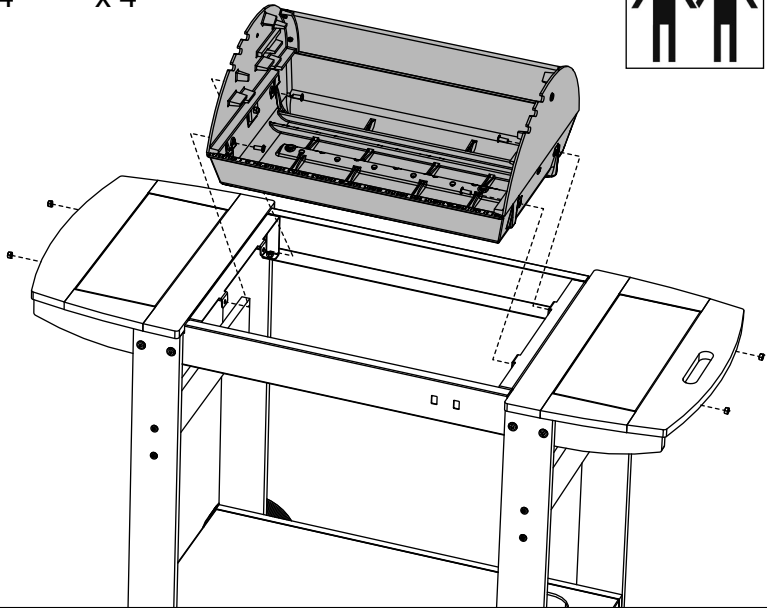

x 4

**8**

Ø4 x 12



x 4

Ø4



x 4

Ø4



x 4

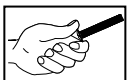
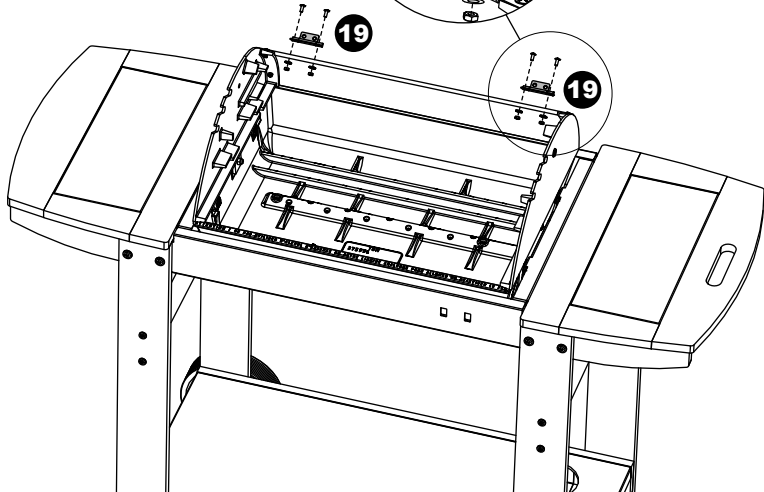
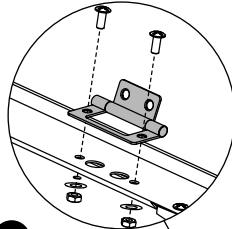

9

Ø4 x 12 Ø4 Ø4

x 4 x 4 x 4

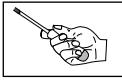
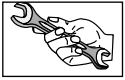
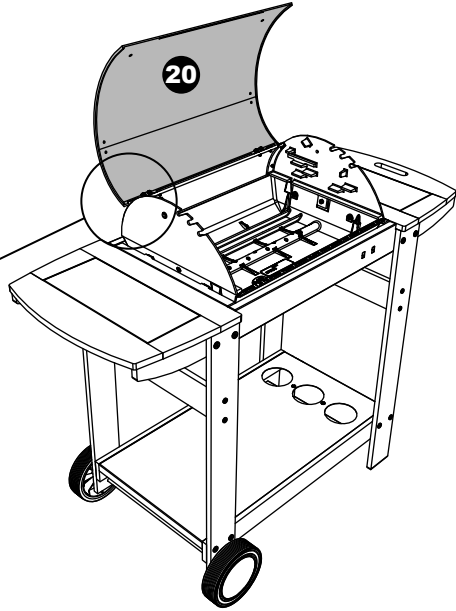
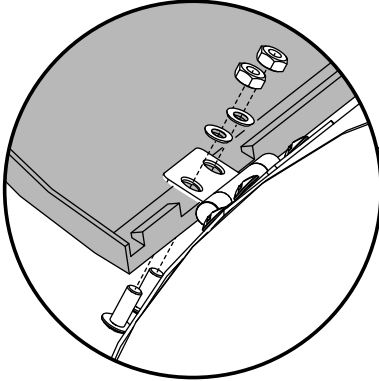
**10**

Ø4 x 12 Ø4 Ø4

x 2 x 2 x 2

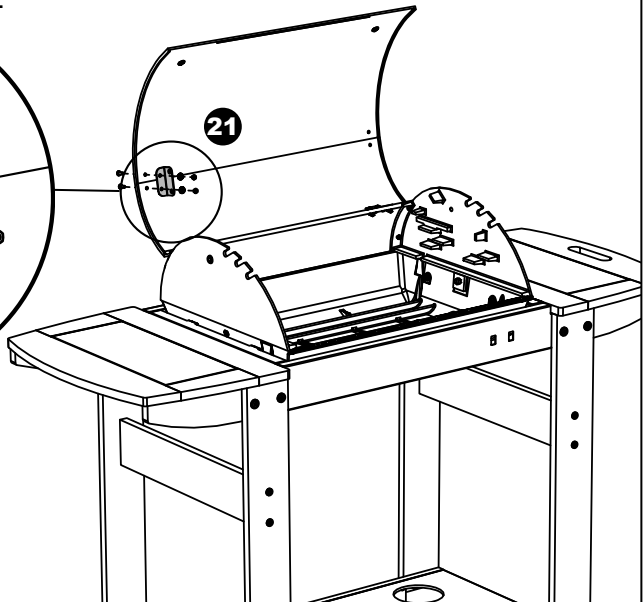
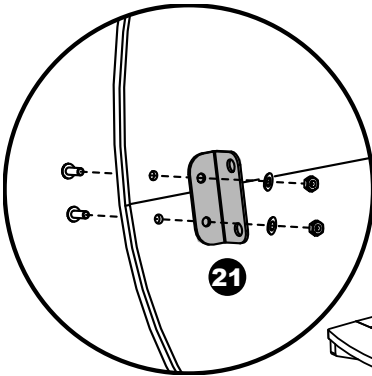

11

Ø4 x 12 Ø4 Ø4

x 2 x 2 x 2

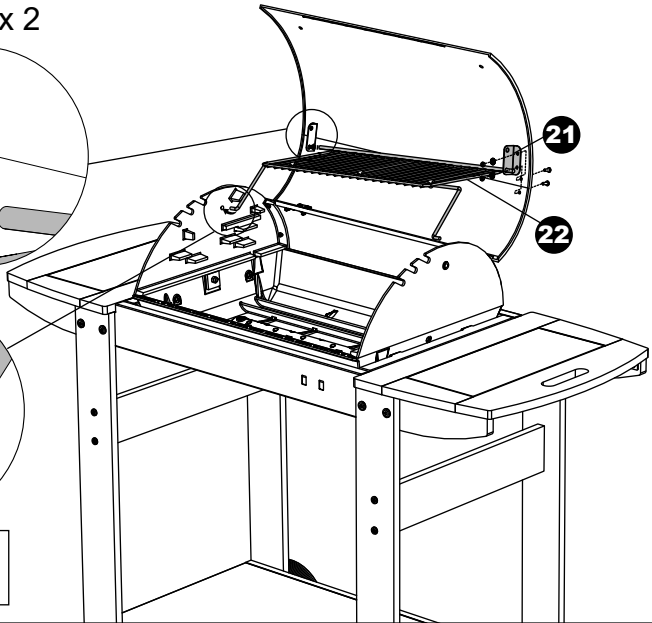
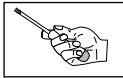
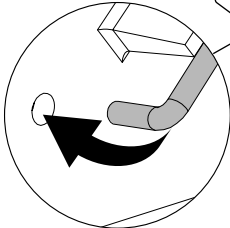
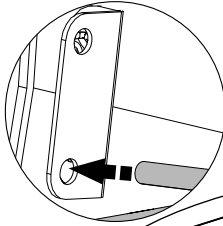
**12**

Ø6 x 40

Ø6 x 20

Ø6

x 1a

x 3b

x 2

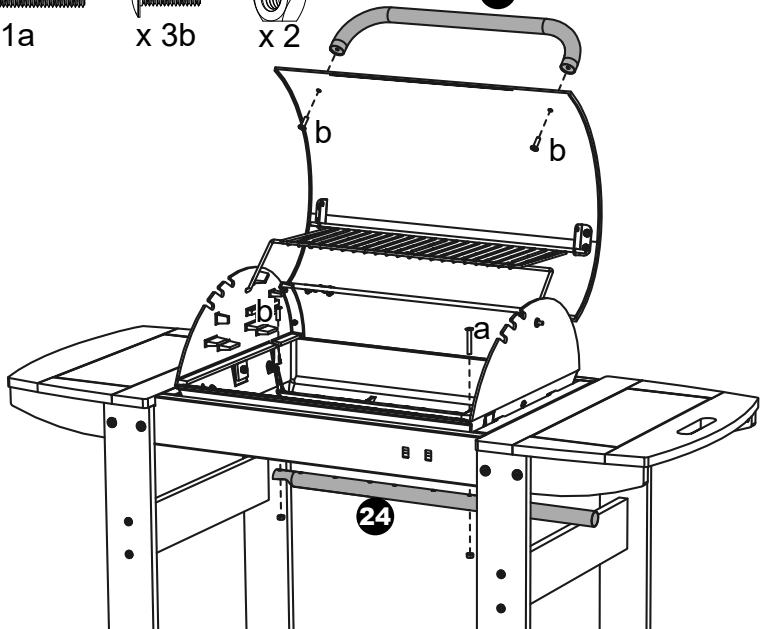
23

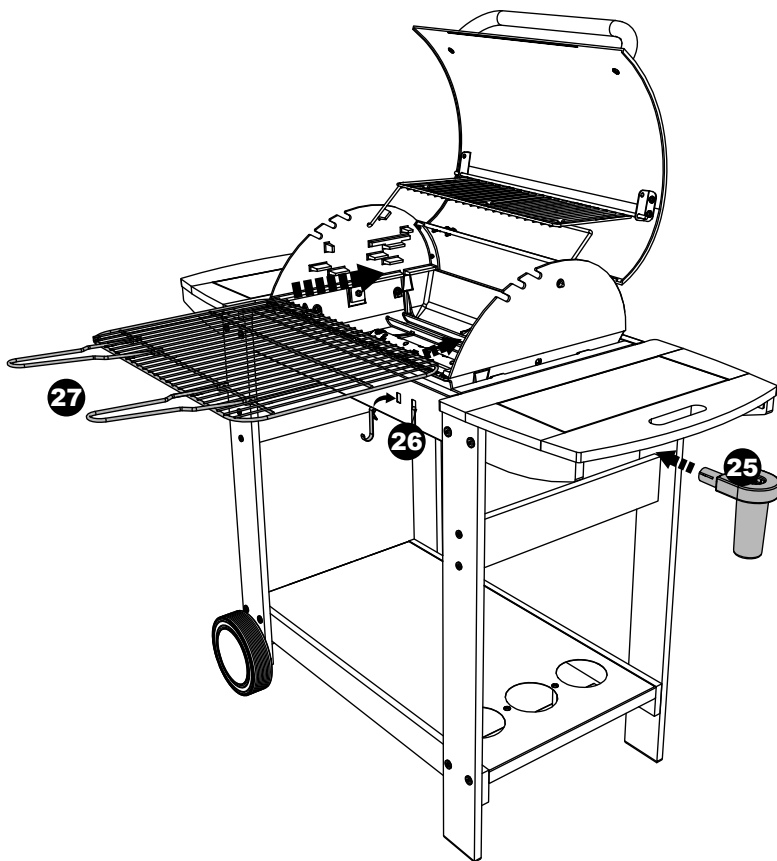
13

FR - La soufflerie fonctionne grâce à une pile de 1,5 Volts référence LR20. (Durée de service environ 10 heures) (Pile non fournie). Ne jamais utiliser la soufflerie au-delà de 5 minutes. Lorsque vous n'utilisez pas la soufflerie, enlevez celle-ci du tube, afin d'éviter sa détérioration.

EN - The blower is powered by a 1,5 V batterie reference LR20. (Service life approximately 10 hours) Never leave the blower running for more than five minutes. When you are not using the blower, remove it from the tube, to avoid it being damaged.

DE - Das Gebläsesystem wird mit einer 1,5 V batterie LR20 betrieben. (Betriebsdauer ca. 10 Stunden). Nie das Gebläsesystem länger als 5 Minuten in Betrieb lassen. Wenn das Gebläsesystem nicht in Betrieb ist, sollte man es aus dem Lüftungsrohr herausnehmen, um eine Beschädigung zu vermeiden.

IT - Il soffietto funziona grazie ad una pila da 1.5 volt di tipo LR20. (Durata di servizio circa 10 ore). Non utilizzate mai il soffietto per più di cinque minuti. Se so utilizzate il soffietto, togliete lo dal tubo per evitare che si deteriori.

PT - Os foles funcionam graças a uma pilha de 1.5 volts referência LR20. (Duração de serviço aproximadamente 10 horas). Nunca utilizar os foles mais de cinco minutos. Quando utiliza os foles, retire-os do turbo para evitar a sua deterioração.

ES - El soplador funciona con una pila de 1,5-voltios referencia LR20. (Duración de servicio aproximadamente). Nunca utilizar el soplador más de 5 minutos. Cuando no se utilice el soplador es conveniente quitarlo del turbo para evitar su deterioro.

NL - Het blaastoestel werkt op een batterijen van 1,5 volt referentie LR20. (Bedrijfsduur ongeveer 10 uur). Gebruik het blaastoestel nooit langer dan 5 minuten. Als u het blaastoestel niet gebruikt dient u het van de buis te verwijderen om beschadigingen te voorkomen.

PL - Dmuchawa działa na baterie 1,5 V typu LR20. (Czas funkcjonowania około 10 godzin). Nie należy używać dmuchawy ponad pięć minut. Jeśli dmuchawa nie funkcjonuje, w celu uniknięcia uszkodzenia jej należy wyjąć ją z rury.