

Oviala

FR

Instructions d'installation
Pergola bioclimatique adossée
OIA taille 3x3m/3x4m

EN

Assembly Instructions
Bioclimatical wall mounted
Pergola
OIA size 3x3m/3x4m

ES

Instrucciones de instalación
Pérgola bioclimática adosada
OIA tamaño 3x3m/3x4m

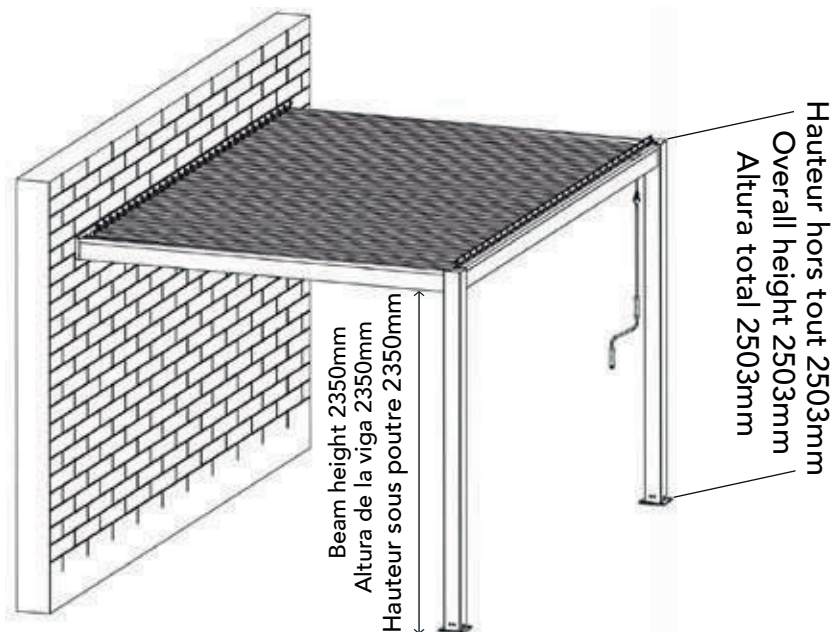

AVANT DE COMMENCER

1. Lire et étudier la notice de montage en entier
2. Repérer les pièces constituant la pergola
3. Regrouper et contrôler les différentes pièces et quincaillerie
4. Se munir de l'outillage nécessaire
5. Aménager une zone de montage dégagée
6. Ne jamais forcer les assemblages. Resserrer les vis après quelques temps d'usage.
7. Garder la notice de montage : si une pièce venait à manquer, elle vous permettra de le signaler au service après vente
8. Nous vous invitons à visionner la vidéo de montage disponible sur notre site internet Oviala.com pour vous aider à identifier les différentes étapes

BEFORE STARTING

1. Read and study the entire manual
2. Locate the parts that make up the pergola
3. Grouping and checking the various parts and hardware
4. Provide the necessary tools
5. Provide a clear assembly area
6. Never force the connections. Tighten the screws after some time of use.
7. Keep the assembly instructions: if a part is missing, it will allow you to report it to the after-sales service
8. We invite you to watch the available video on our website Oviala.com to help you identify the different stages

ANTES DE EMPEZAR

1. Leer y estudiar todo el manual
2. Localiza las piezas que componen la pérgola
3. Agrupar y comprobar las distintas piezas y herrajes
4. Proporcionar las herramientas necesarias
5. Proporcionar una zona de montaje despejada
6. Nunca fuerce las conexiones. Apriete los tornillos después de un tiempo de uso.
7. Conserve las instrucciones de montaje: si una pieza falta, le permitirá informar al el servicio posventa
8. Le invitamos a ver el vídeo del disponible en nuestro sitio web Oviala.com para ayudarle a identificar el diferentes etapas

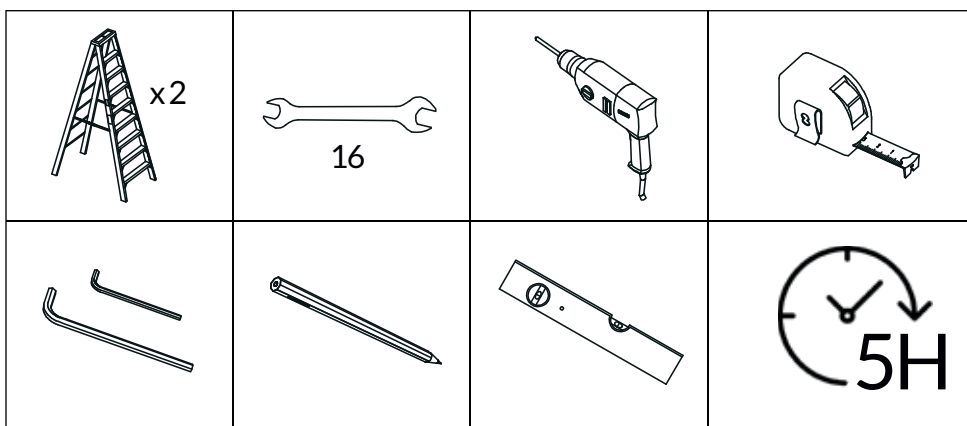
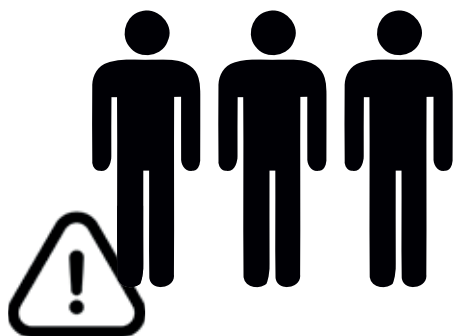



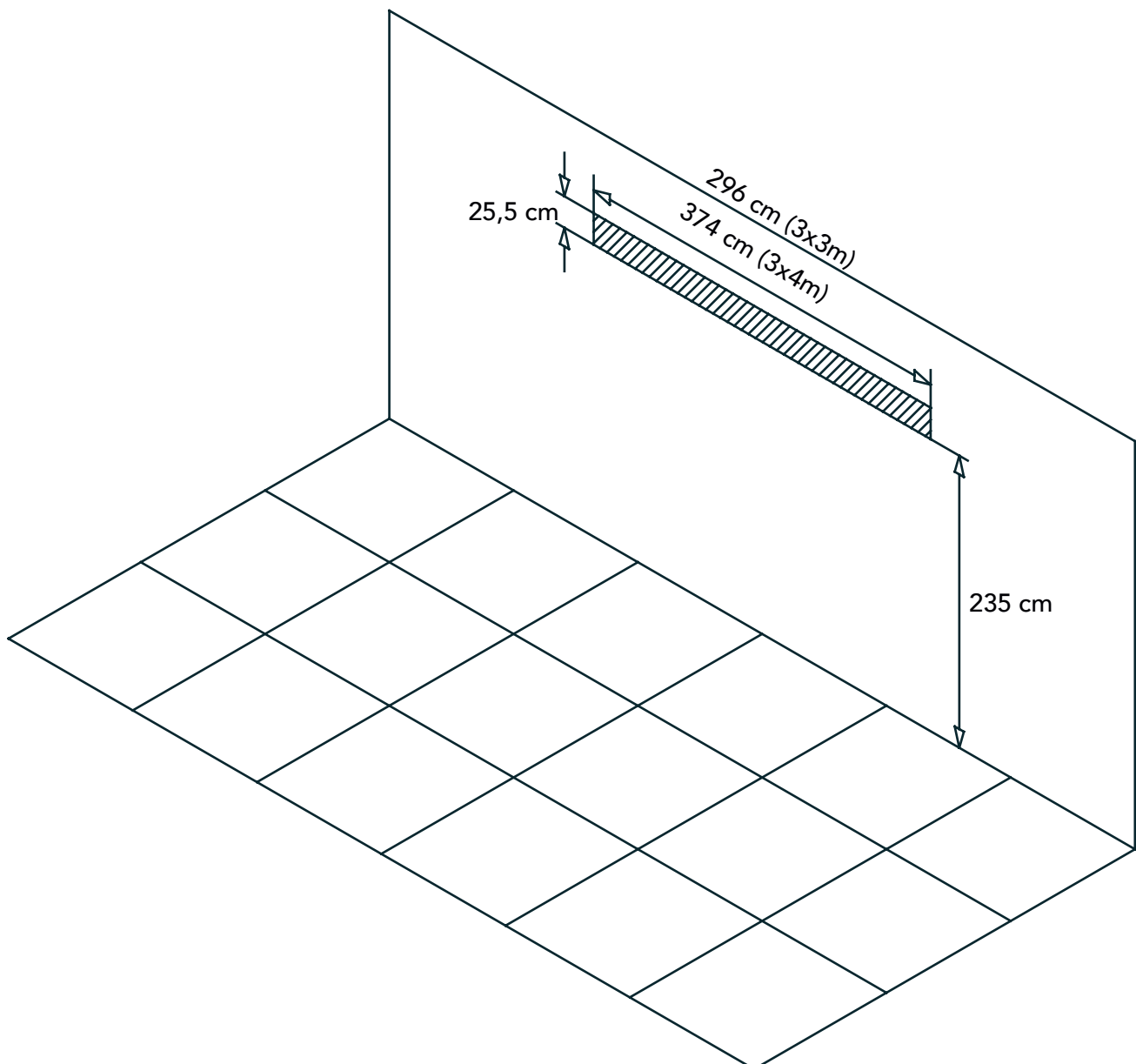





















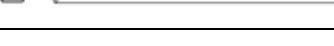

FIXATION MURALE	WALL MOUNTING	MONTAJE EN PARED
<p>1. Assurez vous que le mur choisi pour l'installation soit parfaitement plan et qu'il ne présente pas de défaut structural (fissure, éclat...).</p> <p>2. Contrôlez que vous disposez bien de la place nécessaire à l'installation de la pergola en vous reportant au dimensions indiquées sur le dessin ci dessous</p> <p>3. Les chevilles fournies sont prévues pour une utilisation dans un mur en béton plein. Dans le cas d'un mur creux ou autre matériaux, nous vous recommandons d'adapter la fixation.</p>	<p>1. Make sure that the wall chosen for the installation is perfectly flat and that it has no structural defects (cracks, splinters, etc.).</p> <p>2. Check that you have enough space to install the pergola by referring to the dimensions shown on the drawing below</p> <p>3. The dowels supplied are designed for use in a solid concrete wall. In the case of a hollow wall or other materials, we recommend that you adapt the fixing.</p>	<p>1. Asegúrese de que la pared elegida para la instalación es perfectamente plana y que no tiene defectos estructurales (grietas, astillas, etc.).</p> <p>2. Compruebe que dispone de espacio suficiente para instalar la pérgola consultando las dimensiones indicadas en el siguiente dibujo</p> <p>3. Los tacos suministrados están diseñados para ser utilizados en un muro de hormigón sólido. En el caso de una pared hueca u otros materiales, se recomienda adaptar la fijación.</p>

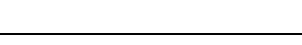





CONSIGNES À OBSERVER	INSTRUCTIONS TO FOLLOW	INSTRUCCIONES A SEGUIR
<p>1. Installer la pergola par temps sec et sans vent.</p> <p>2. Trois personnes sont nécessaires pour le montage.</p> <p>3. Porter des gants de sécurité, des verres protecteurs et des vêtements à manches longues pendant toute la durée d'installation. Afin d'éviter toute blessure, faire attention aux angles vifs de quelques éléments.</p> <p>4. Tenir les enfants à l'écart du lieu de montage.</p> <p>5. Ne pas s'appuyer sur la pergola durant la phase de montage.</p> <p>6. Contrôler les aplombs et les niveaux.</p> <p>7. Ne pas grimper ni se tenir debout sur les lames orientables, en raison du risque de chute.</p>	<p>1. Install the pergola in dry and windless weather.</p> <p>2. Three people are needed for the installation.</p> <p>3. Wear safety gloves, safety glasses and long-sleeved clothing during the entire installation process. To avoid injury, pay attention to the sharp edges of some elements.</p> <p>4. Keep children away from the installation area.</p> <p>5. Do not lean on the pergola during the installation phase.</p> <p>6. Check that the posts are level and plumb.</p> <p>7. Do not climb or stand on the adjustable slats, as there is a risk of falling.</p>	<p>1. Instale la pérgola con tiempo seco y sin viento.</p> <p>2. Se necesitan tres personas para la instalación.</p> <p>3. Utilice guantes de seguridad, gafas de seguridad y ropa de manga larga durante todo el proceso de instalación. Para evitar lesiones, preste atención a los bordes afilados de algunos elementos.</p> <p>4. Mantenga a los niños alejados de la zona de instalación.</p> <p>5. No se apoye en la pérgola durante la fase de instalación.</p> <p>6. Compruebe que los postes están nivelados y a plomo.</p> <p>7. No se suba ni se ponga de pie sobre las planchas ajustables, ya que existe riesgo de caída.</p>

LISTE PIÈCES ET QUINCAILLERIE	PARTS LIST AND HARDWARE	LISTA DE PIEZAS Y HARDWARE
-------------------------------	-------------------------	----------------------------

		3x3m	3x4m			3x3m	3x4m
1		x8	x8	15		x3	x4
2		x2	x2	16		x2	x2
3		x2	x2	A		x1	x1
4		x2	x2	B		x1	x1
5		x1	x1	C		x2	x2
6		x66	x84	D1		x1	x1
7		x46	x64	D2		x1	x1
8		x46	x64	E		x2	x2
9		x1	x1	F1		x1	x1
10		x14	x16	F2		x1	x1
11		x2	x2	G		x21	x30
12		x1	x1	H		x1	x1
13		x3	x4	I		x1	x1
14		x4	x4	J		x2	x2

<p>Étape 1 : Montage des platines sur les poteaux Retirer les vis présentes sur les haut des poteaux pour préparer l'étape suivante</p>	<p>Step 1 : Assembling bases on posts. Please remove the screws at the top of the posts to prepare the next step</p>	<p>Paso 1 : Montaje de las bases en los postes. Por favor, retire los tornillos en la parte superior de los postes para preparar el siguiente paso</p>
--	---	---

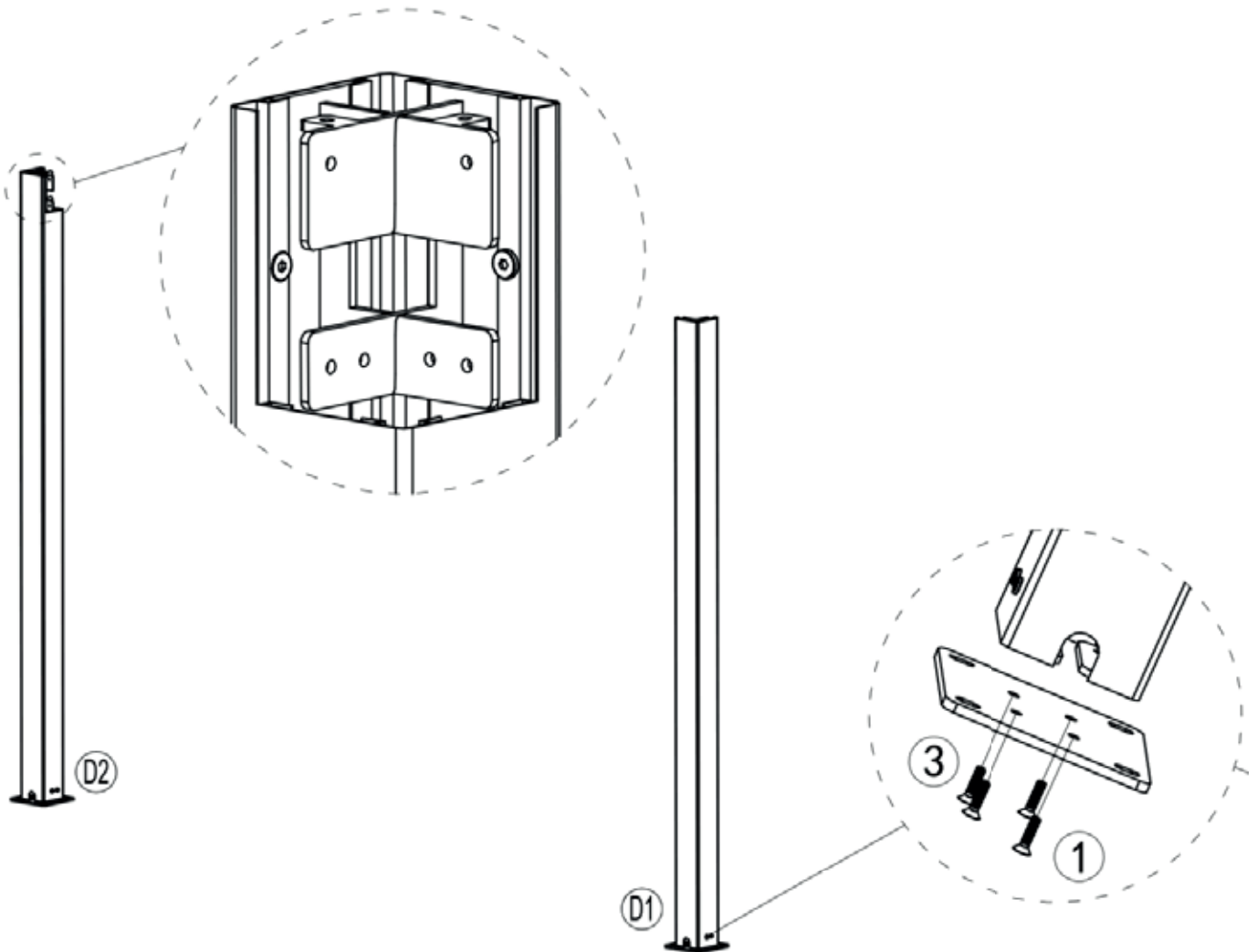

① x8	③ x2
	
D1 x1	D2 x1
	



Étape 2 :
Assemblage des poteaux
sur les traverses
à encoches

Step 2 :
Assembling the posts
to the notched crossbeams

Paso 2 :
Montaje de los postes en
los travesaños dentados

⑥ x 12	
Ⓐ x 1	Ⓑ x 1
	

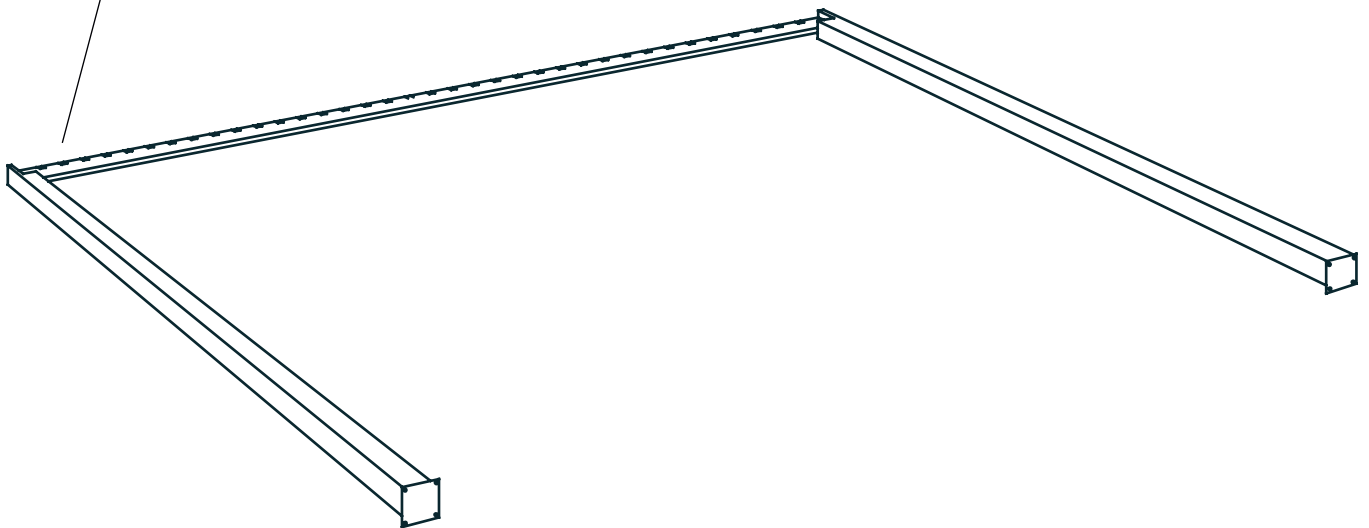
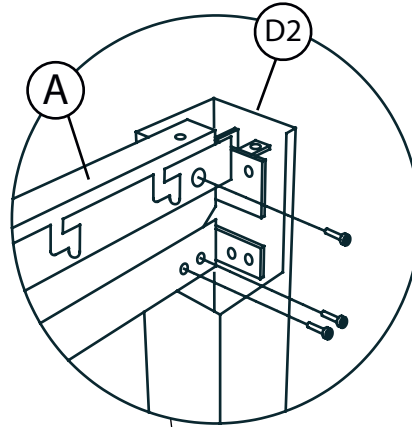
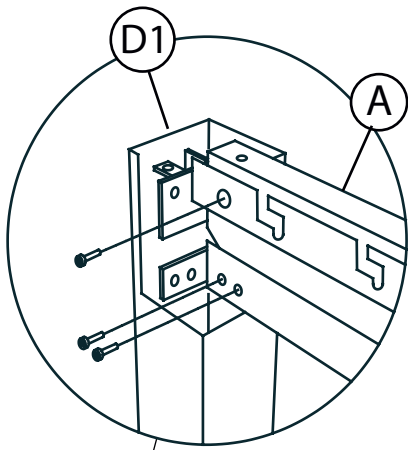



Étape 3 :
Tracé, perçage et installation
des fixations murales

Step 3 :
Layout, drilling and
instalation of wall fixings



Paso 3 :
Disposición, perforación e
instalación de las fijaciones a
la pared

3x3 m

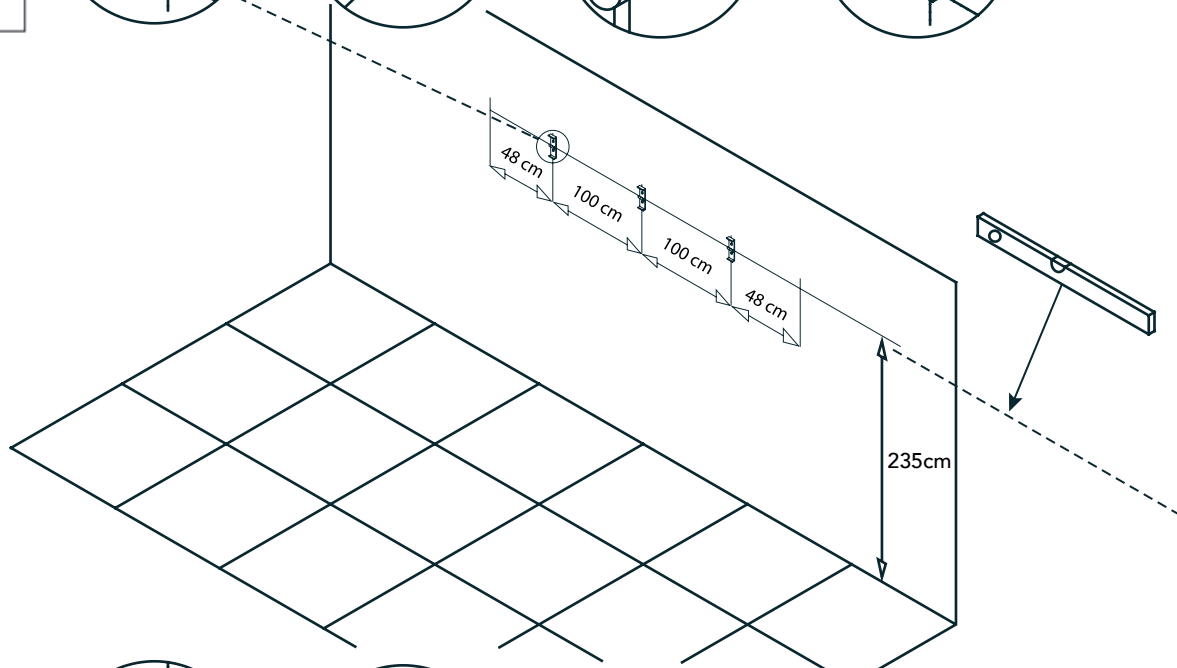
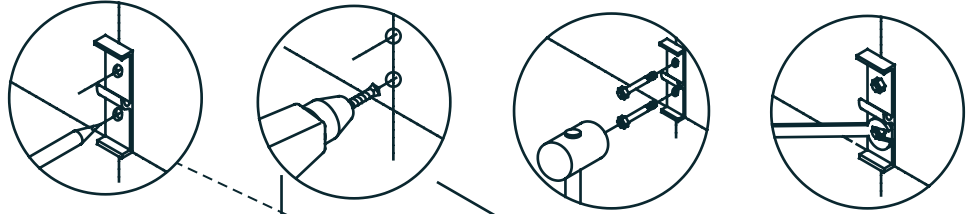
⑩ x6	
⑬ x3	



3x4 m

⑩ x8	
⑬ x4	

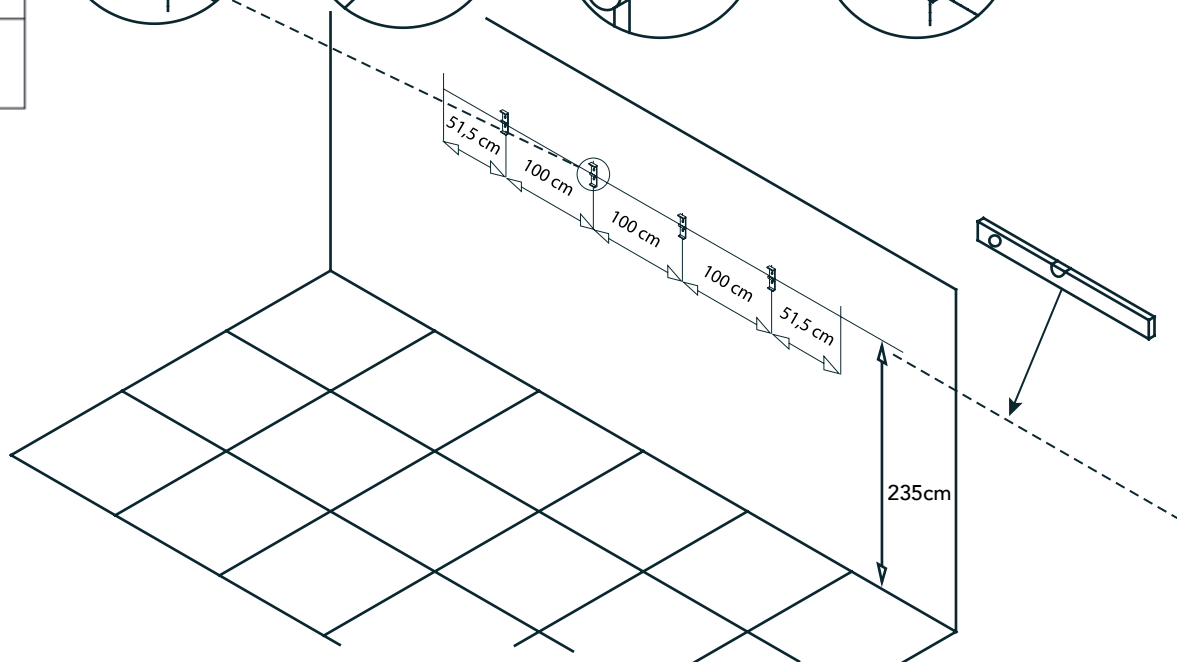
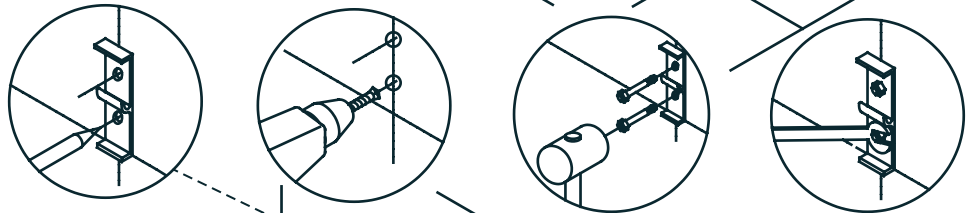

Étape 4 :
Installation de la traverse
murale

Step 4 :
Wall cross beam
mounting

Paso 4 :
Instalación del larguero
mural

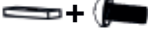
Ⓑ x1	
Ⓜ x4	

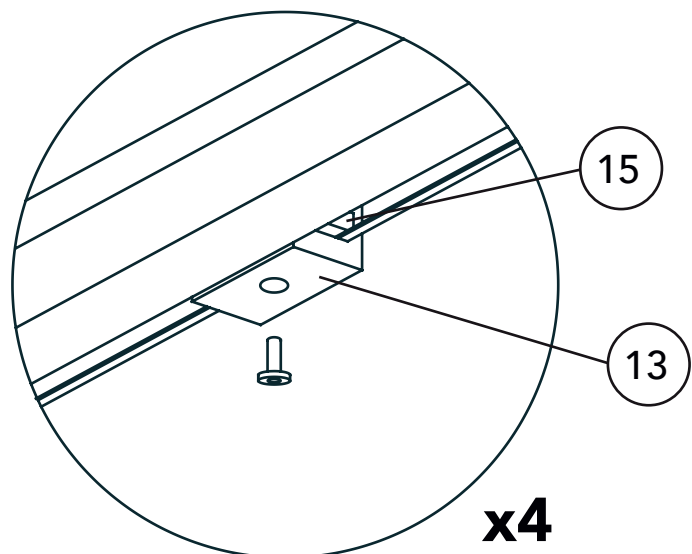
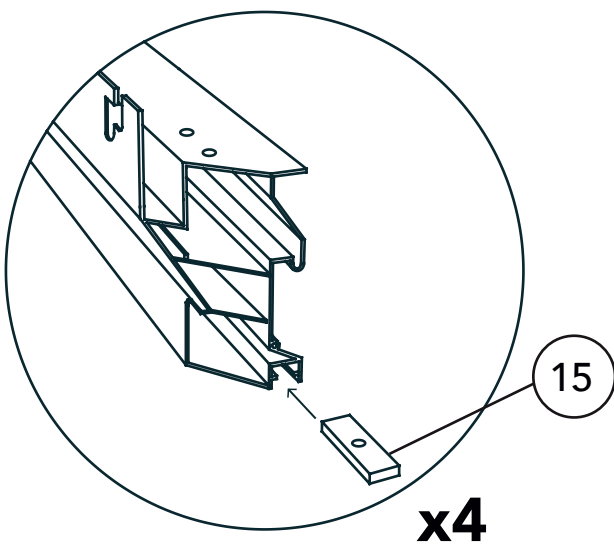
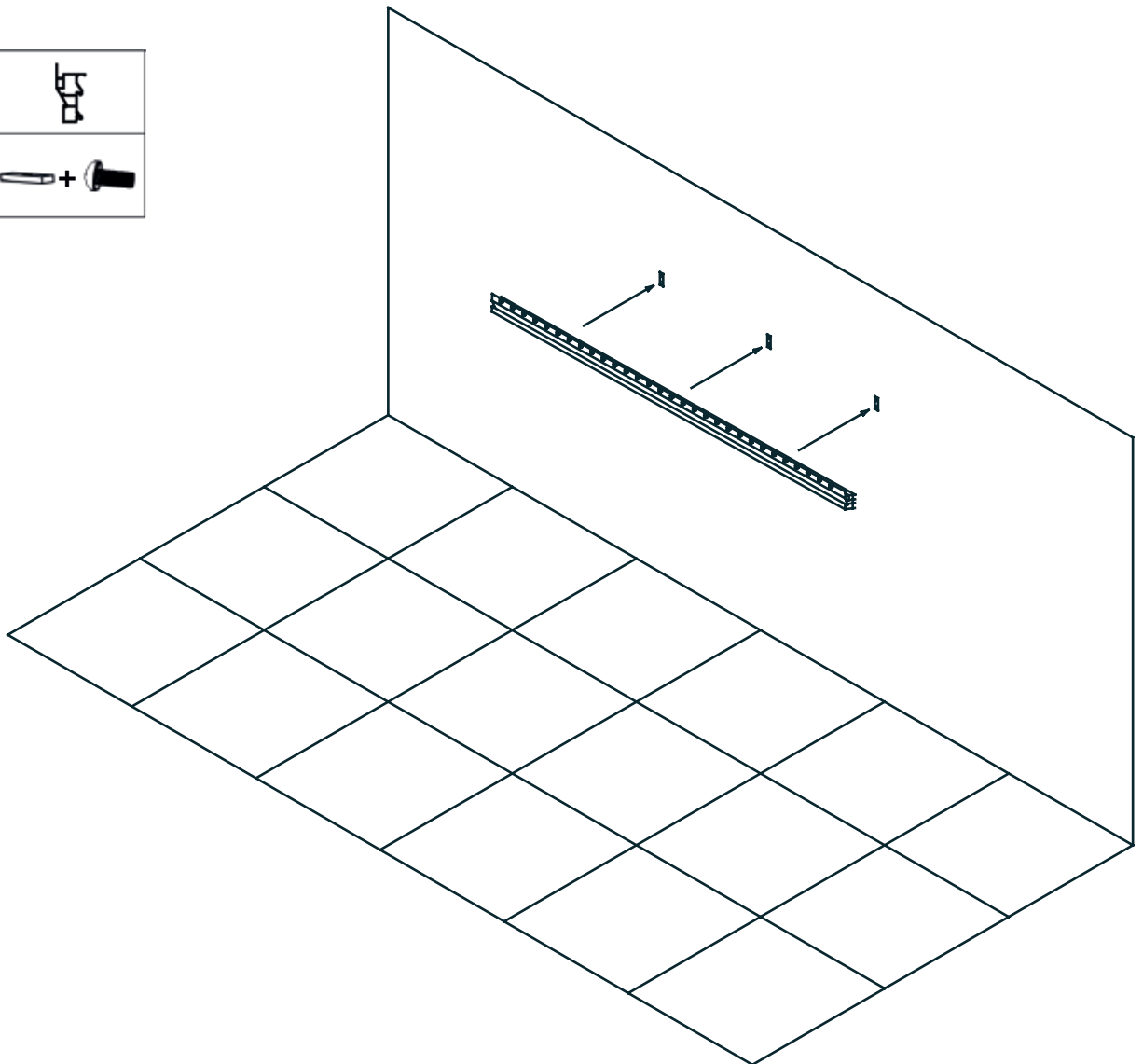

Étape 5 :
Installation des équerres sur
la traverse murale

Step 5 :
Scare assembly on the wall
cross beam

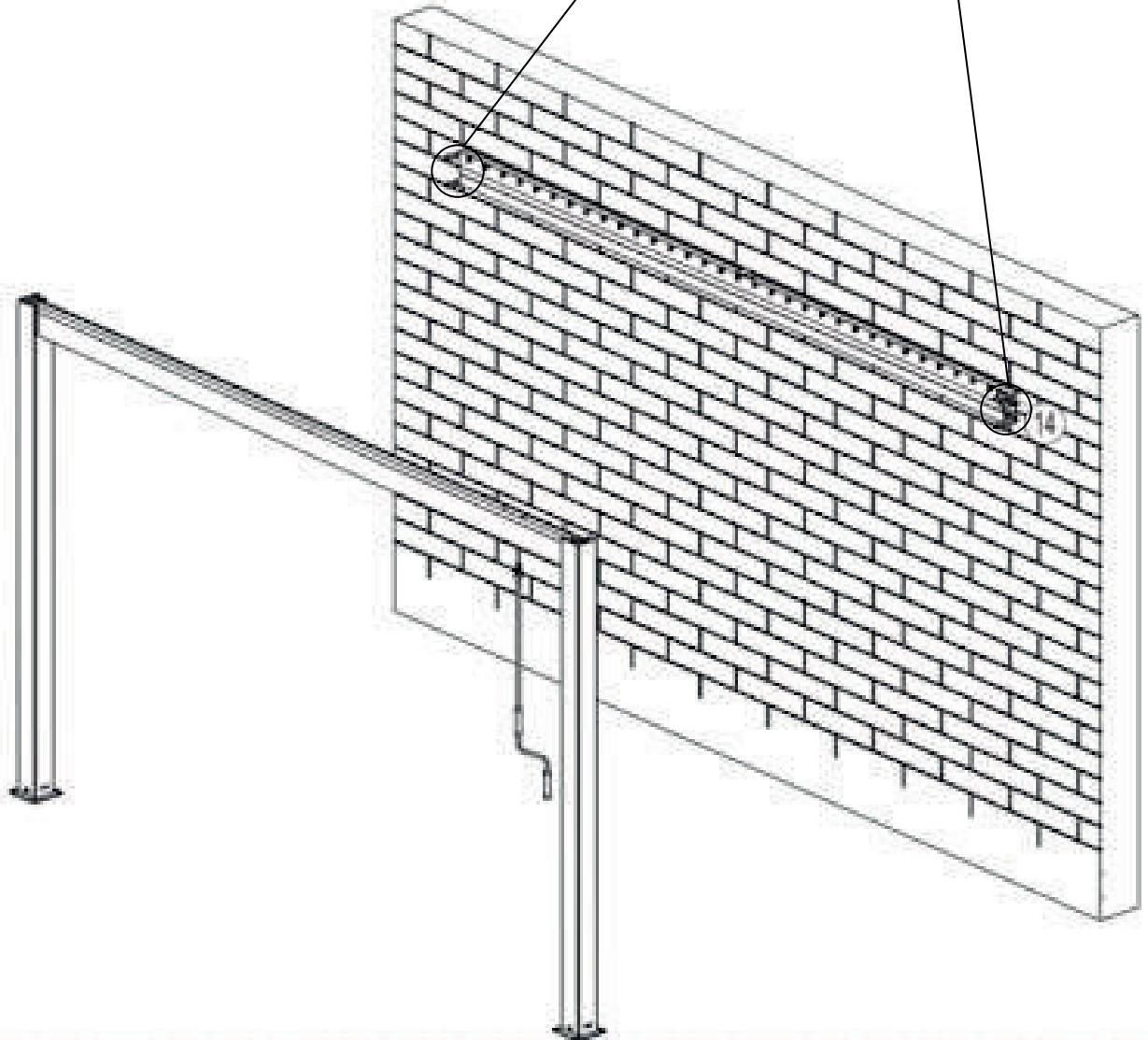
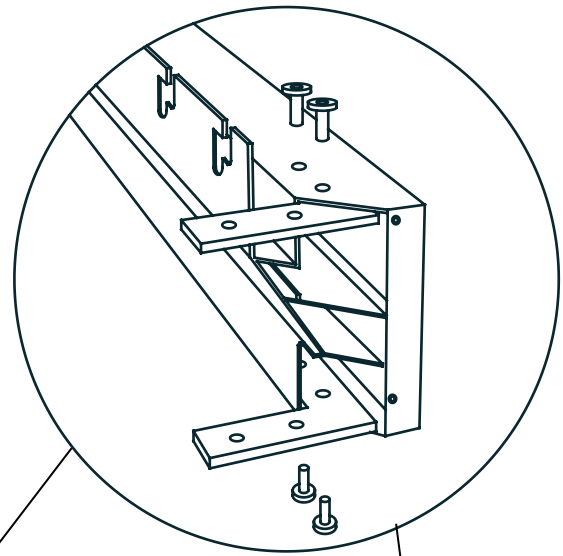
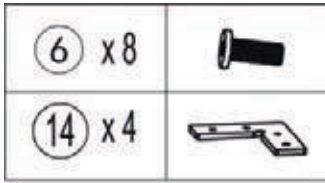

Paso 5 :
Montaje del mieda en la viga
transversal de la pared



Étape 5 :
Assemblage des
traverses

Step 5 :
Assembly of the
simple cross beams

Paso 5 :
Montaje de
durmientes

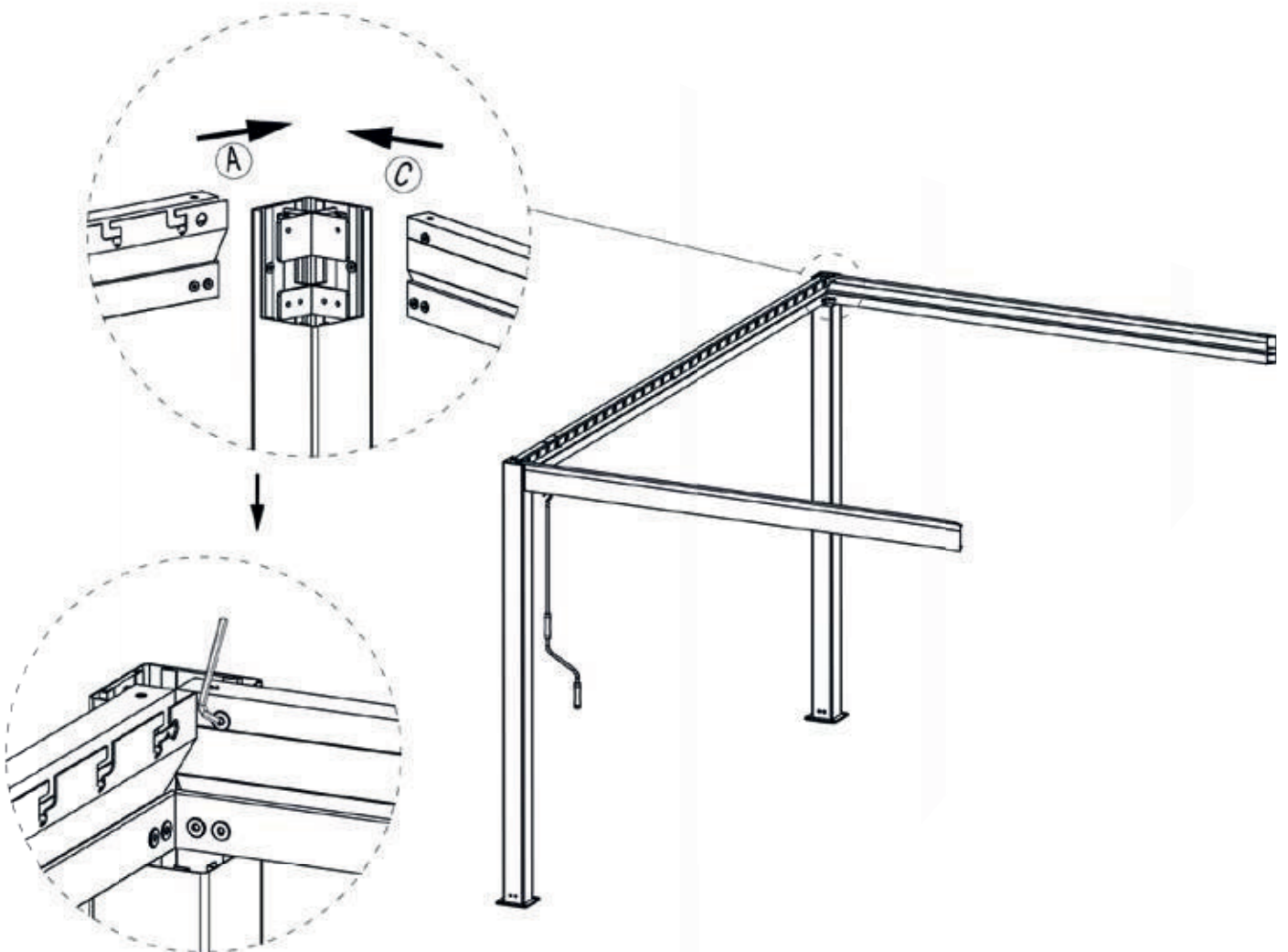

⑥ x 12	
③ x 2	



Étape 6 :
Assemblage des traverses
simples sur la traverse
murale

Step 6 :
Assembling the single
crosspieces to the wall

Paso 6 :
Montaje de los raíles
individuales en el raíl de la
pared

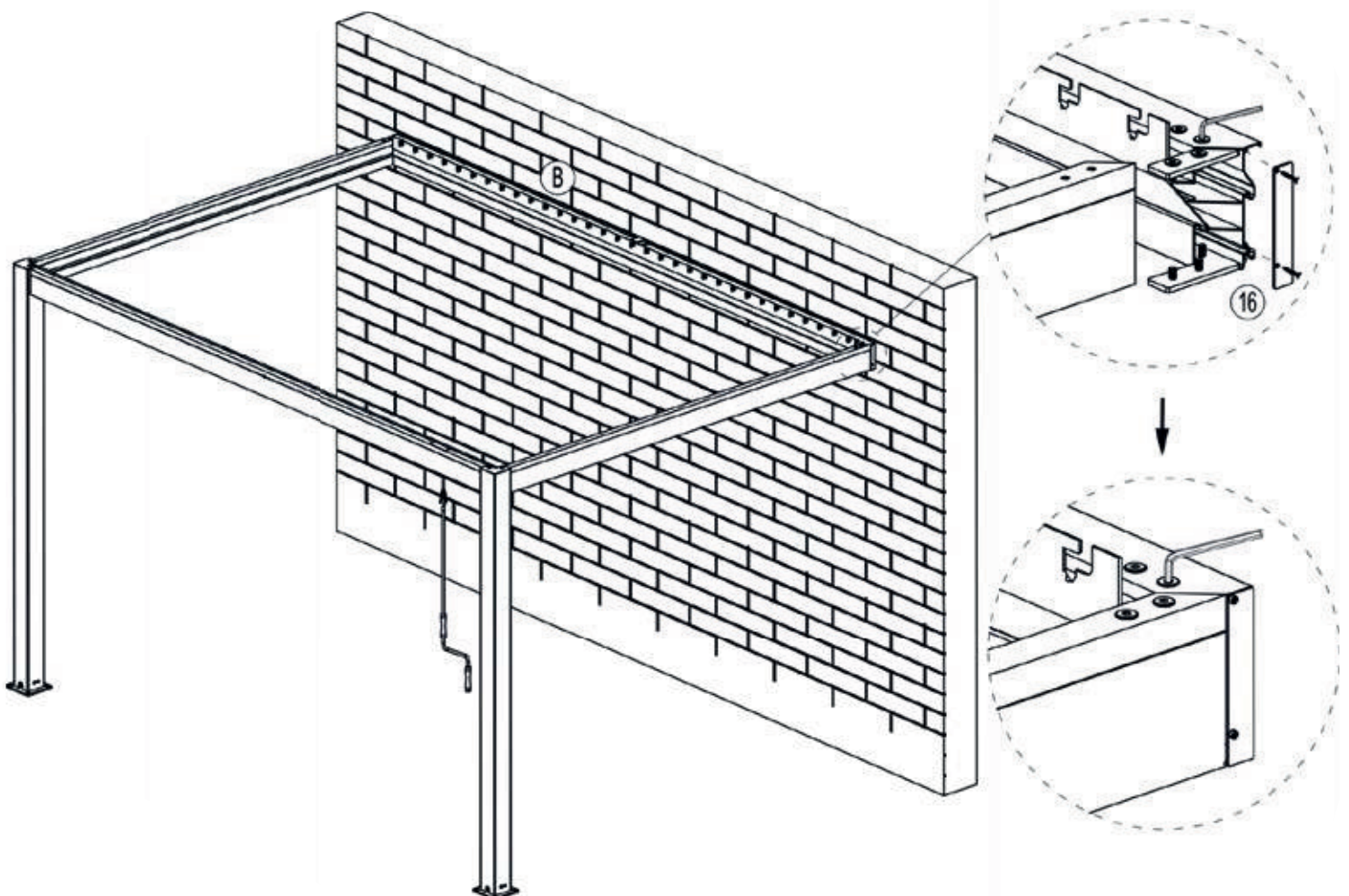

①6 x 4	
①6 x 2	
⑥ x 8	



Étape 7 :
Assemblage des couvercles
sur les poteaux

Step 7 :
Assembling the covers
on the posts

Paso 7 :
Montaje de las cubiertas
en los puestos



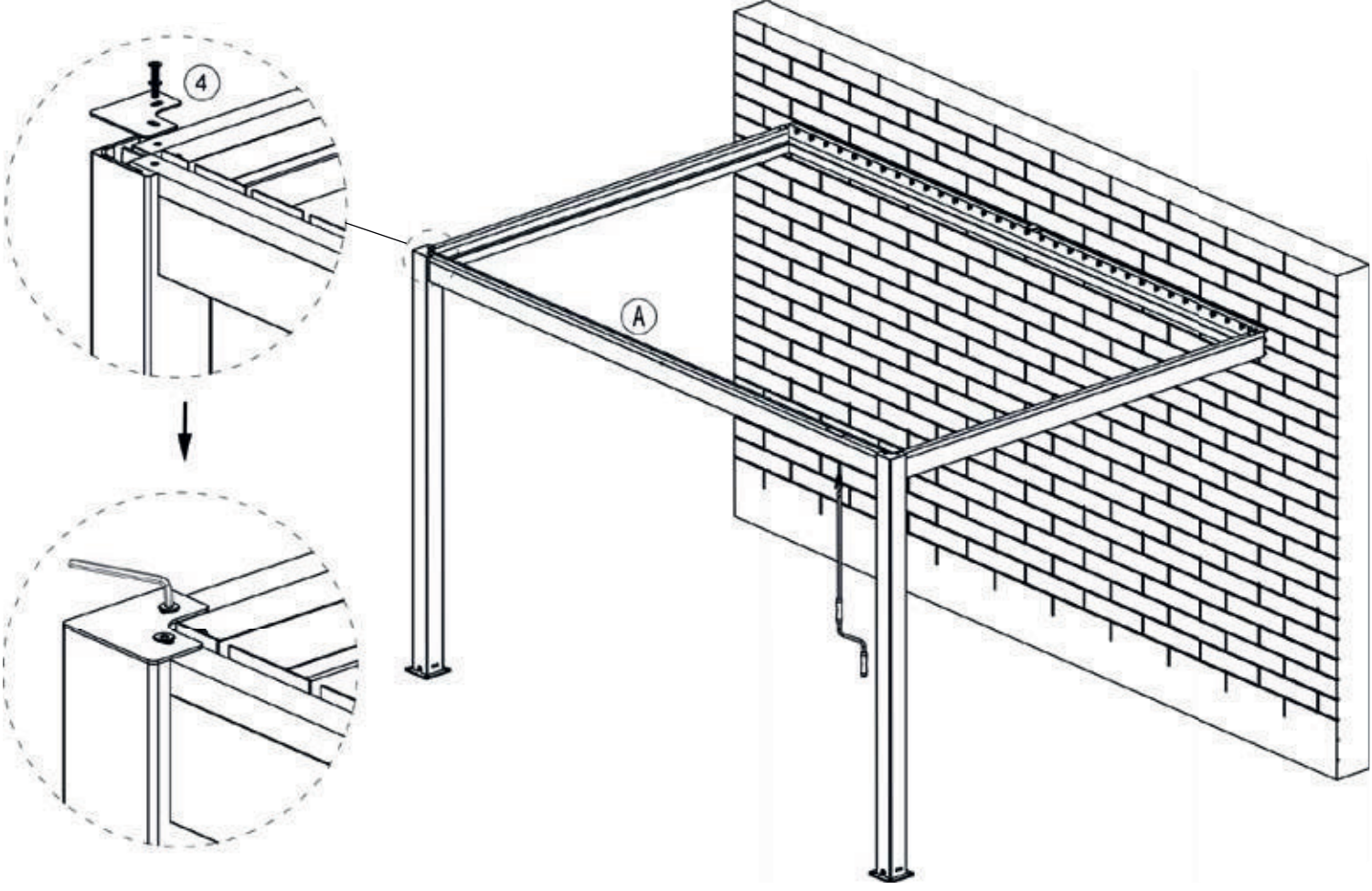

6 x4	
4 x2	



Étape 8 :
Assemblage des gouttières

Step 8 :
Assembling of the gutters

Paso 8 :
Montaje de los canalones



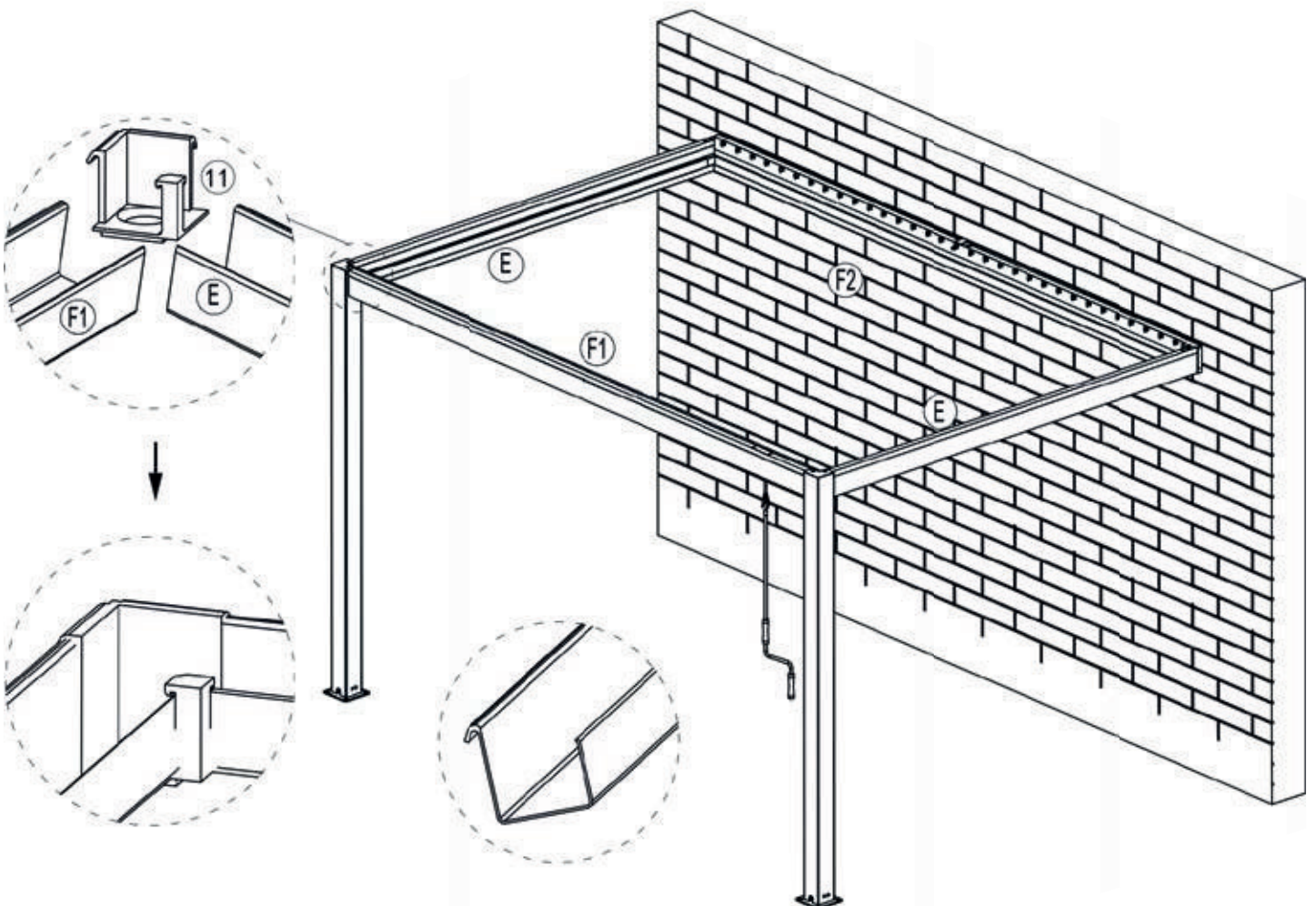



ⓔ x2		Ⓜ1 x2	
ⓕ1 x1		ⓕ2 x1	



**Étape 9 :
Montage des lammes**

**Step 9 :
Assembling of the slats**

**Paso 9 :
Montaje de las lamas**



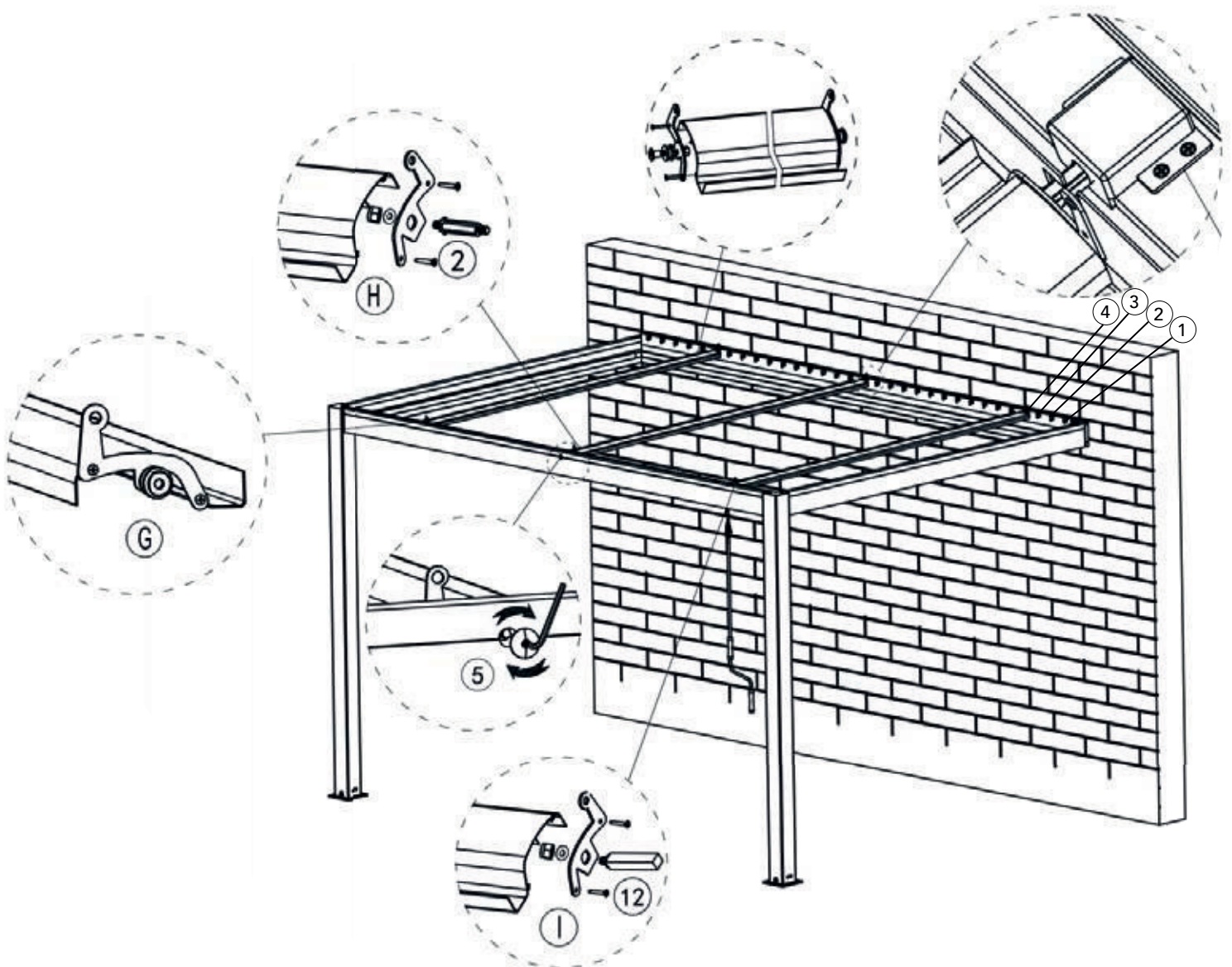

⑤ x1		
⑥ x30	⑦ x1	⑧ x1
		
⑨ x2		
⑫ x1		



Étape 10 :
Montage des profils en L

Step 10 :
Assembling of the L profiles

Paso 10 :
Montaje de los perfiles L

⑥ x 64	⑦ x 64	⑧ x 64	ⓐ x 2
			



FR: Ne pas serrer les écrous ⑧ à fond, les lames doivent pouvoir pivoter facilement.

EN: Do not tighten nuts ⑧ all the way, the louvers must be able to turn easily.

ES: No apriete demasiado las tuercas ⑧, ya que los listones deben pivotar con facilidad.

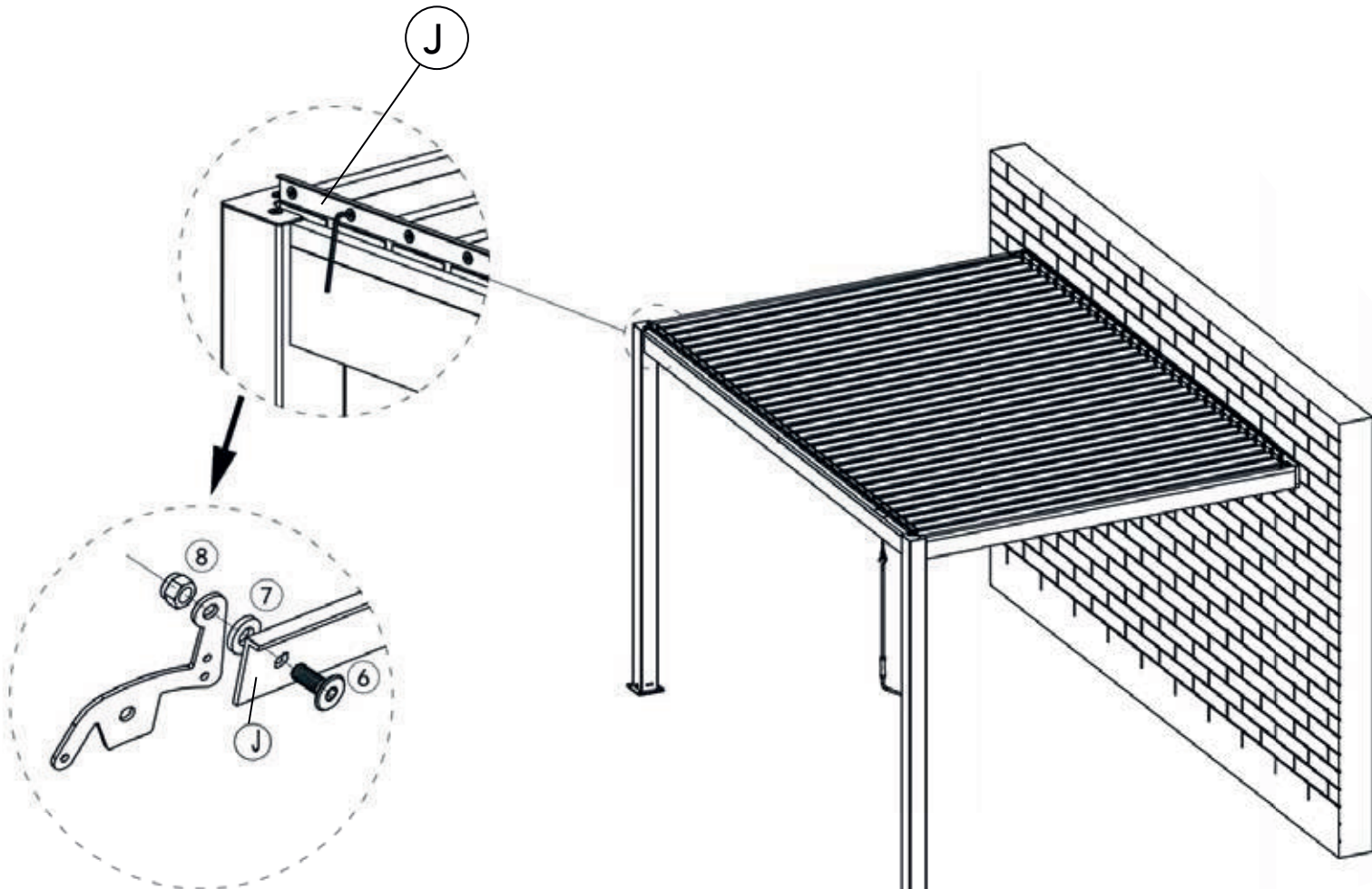

**Étape 11 :
Fixation au sol**

Positionner les pieds de la pergola à l'endroit désiré en respectant les dimensions ci dessous.

Les chevilles fournies sont exclusivement destinées à un sol en béton. Pour un autre type de sol veuillez utiliser un mode de fixation adapté.

**Step 11 :
Floor fixation**

Position the legs of the pergola in the desired location, respecting the dimensions below.

The dowels supplied are only suitable for concrete floors. For other types of floor, please use a suitable fixing method.

**Paso 11 :
Montaje de las lamias**

Coloque las patas de la pergola en el lugar deseado, respetando las dimensiones indicadas a continuación.

Los tacos suministrados sólo son adecuados para suelos de hormigón. Para otros tipos de suelo, utilice un método de fijación adecuado.

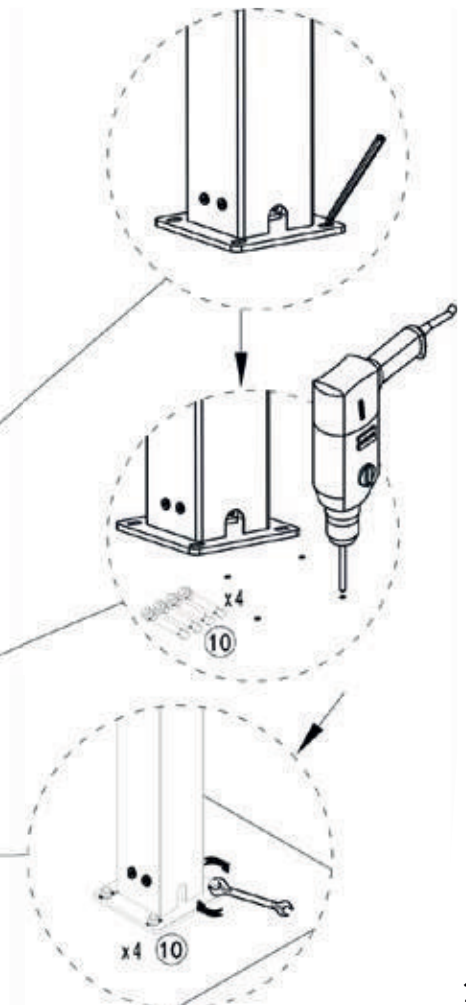
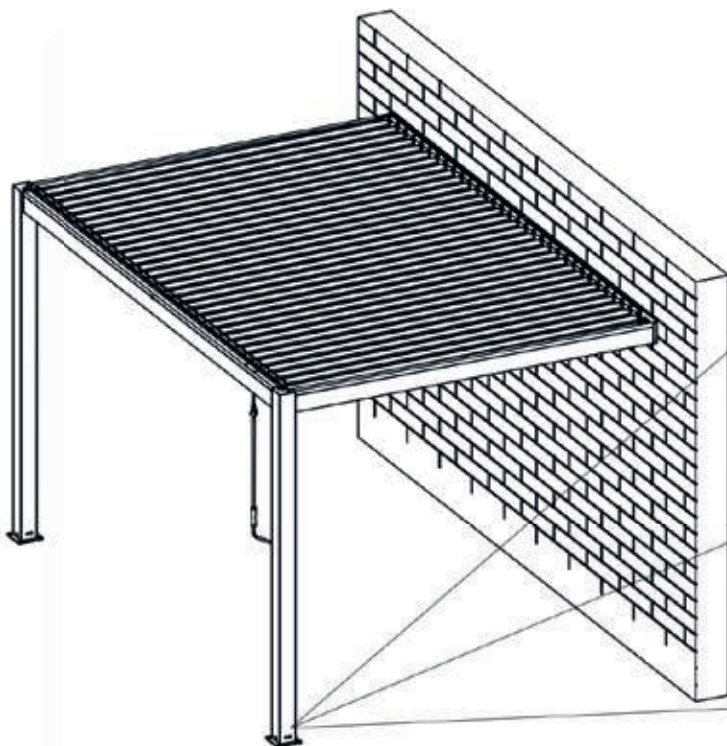
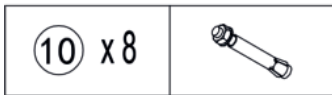
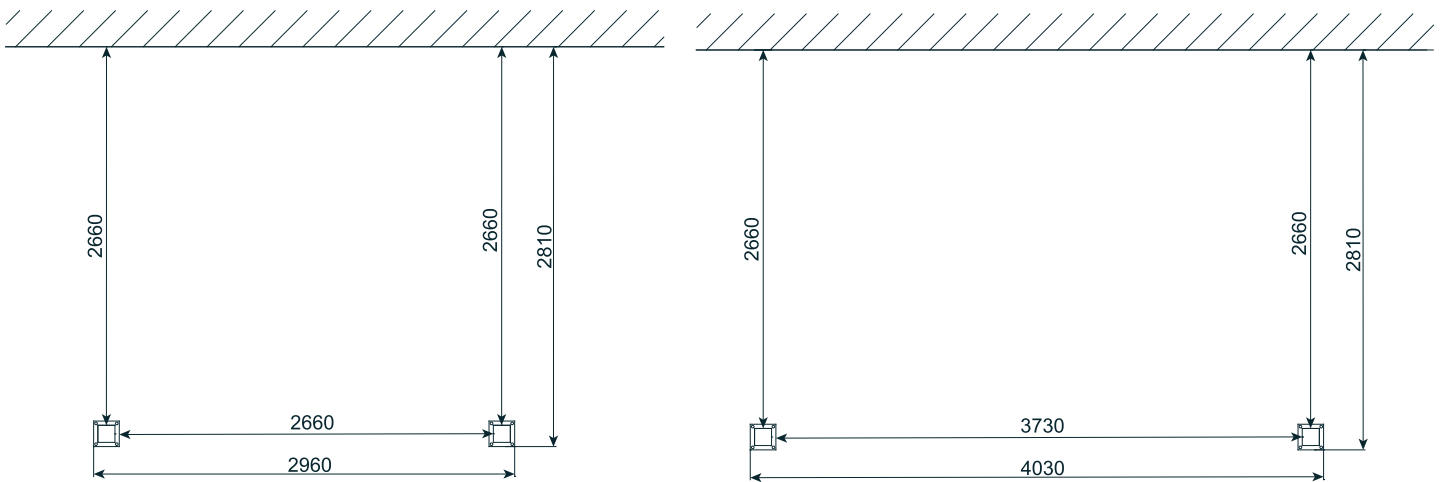

FR GARANTIE :

Votre pergola est garantie 2 ans, sauf pour les pièces d'usure telles que le système de manoeuvre et les joints des lames.

Votre garantie couvre les défauts de fabrication et les vices cachés.

Pour en bénéficier votre pergola doit :

- Etre posée conformément à la notice
- Etre entretenue régulièrement
- Etre utilisée normalement et sans avoir subi de modifications

Facteurs d'exclusion de la garantie :

- Le non-respect des conditions citées ci-dessus
- Les défauts apparents non signalés avant la mise en oeuvre du produit
- Les détériorations consécutives au montage ou à une mauvaise utilisation
- Les dommages causés par un événement extérieur.

Mise en oeuvre de la garantie :

- La garantie est limitée au remplacement des pièces défectueuses, à l'exclusion de la réparation de tout autre préjudice
- Voir avec votre point de vente :
 - Les éléments d'achats (facture, numéro commande d'origine)
 - Une description du problème
 - Des photos facilitant la compréhension

CONDITIONS D'UTILISATION:

Nos pergolas bioclimatiques sont des produits entièrement démontables et temporaires, elles n'entrent pas dans la catégorie des ouvrages permanents. Elles sont conçues pour un usage domestique et en aucun cas pour une utilisation en collectivité, elles ne sont pas soumises à la réglementation des ouvrages recevant du public. Toute utilisation d'appareil chauffant (barbecue, plancha, chauffage d'extérieur) sous ou à proximité de la pergola est interdite. En cas de vent ou de chute de neige, il est recommandé de laisser les lames ouvertes. L'épaisseur de la neige ne doit jamais excéder une épaisseur de 10cm, déblayer si nécessaire. En cas de phénomène météorologique exceptionnel ou de vent violent (plus de 90km/h), la pergola doit être démontée et rangée à l'abri.

ENTRETIEN :

Pour conserver son aspect d'origine nettoyer régulièrement à l'aide d'un chiffon humide, du savon et de l'eau tiède. Ne pas utiliser de détergents agressifs ou abrasifs Il est normal de constater une légère alteration de la couleur avec le temps et l'usage.

MAINTENANCE :

Vérifier le serrage des vis une fois par an. S'assurer régulièrement que rien n'obstrue l'évacuation de l'eau dans les gouttières. Ne pas actionner les lames en cas de gel ou de neige. La pergola n'assure pas une étanchéité parfaite, en cas de fortes précipitations, il est possible que de l'eau traverse le toit de la pergola.

EN GUARANTEE :

Your pergola is guaranteed for 2 years, except for parts subject to wear and tear such as the operating system and the slat seals.

Your guarantee covers manufacturing defects and hidden faults.

To benefit from this guarantee your pergola must :

- Be installed in accordance with the instructions
- Be regularly maintained
- Be used normally and not have been modified

Factors excluding the guarantee :

- Failure to comply with the above conditions
- Apparent defects not reported before the product is used
- Damage caused by assembly or misuse
- Damage caused by an external event.

Implementation of the guarantee :

- The warranty is limited to the replacement of defective parts, to the exclusion of compensation for any other damage
- See your point of sale :
 - Purchase details (invoice, original order number)
 - A description of the problem
 - Photos to help you understand the problem

CONDITIONS OF USE:

Our bioclimatic pergolas are entirely removable and temporary products, they do not fall into the category of permanent structures. They are designed for domestic use and in no case for use in a community, they are not subject to the regulations for structures receiving the public. Any use of heating equipment (barbecue, plancha, outdoor heating) under or near the pergola is prohibited. In the event of wind or snowfall, it is recommended that the slats are left open. The snow should never be more than 10cm deep and should be cleared away if necessary. In the event of exceptional weather conditions or strong winds (over 90km/h), the pergola must be dismantled and stored under cover.

CLEANING :

To maintain its original appearance clean regularly with a damp cloth, soap and warm water. Do not use aggressive or abrasive detergents
It is normal to notice a slight alteration of the colour with time and use.

MAINTENANCE :

Check the tightness of the screws once a year. Regularly check that there are no obstructions in the gutters. Do not operate the slats in case of frost or snow.

ES GUARANTEE :

Su pérgola está garantizada durante 2 años, excepto las piezas sujetas a desgaste, como el sistema de funcionamiento y las juntas de las lamas.

Su garantía cubre los defectos de fabricación y los vicios ocultos.

Para beneficiarse de esta garantía, su pérgola debe :

- Ser instalado de acuerdo con las instrucciones
- Ser mantenido regularmente
- Ser utilizado normalmente y sin haber sufrido ninguna modificación

Factores que excluyen la garantía :

- Incumplimiento de las condiciones anteriores
- Defectos aparentes no comunicados antes de la utilización del producto
- Daños causados por el montaje o el mal uso
- Daños causados por un evento externo.

Aplicación de la garantía :

- La garantía se limita a la sustitución de las piezas defectuosas, con exclusión de la indemnización por cualquier otro daño
- Vea su punto de venta :
 - Detalles de la compra (factura, número de pedido original)
 - Una descripción del problema
 - Fotos para ayudarle a entender el problema

CONDICIONES DE USO:

Nuestras pérgolas bioclimáticas son productos totalmente desmontables y temporales, no entran en la categoría de estructuras permanentes. Están diseñadas para uso doméstico y en ningún caso para uso en una comunidad, no están sujetas a la normativa para estructuras que reciben al público. Se prohíbe el uso de equipos de calefacción (barbacoa, plancha, calefacción exterior) debajo o cerca de la pérgola. En caso de viento o nevadas, se recomienda dejar las lamas abiertas. La nieve nunca debe tener más de 10 cm de profundidad y debe retirarse si es necesario. En caso de condiciones meteorológicas excepcionales o de vientos fuertes (más de 90 km/h), la pérgola debe desmontarse y guardarse a cubierto.

LIMPIEZA :

Para mantener su aspecto original limpie regularmente con un paño húmedo, jabón y agua tibia. No utilice detergentes agresivos o abrasivos.
Es normal notar una ligera alteración del color con el tiempo y el uso.

MANTENIMIENTO :

Compruebe el apriete de los tornillos una vez al año. Compruebe regularmente que no hay obstrucciones en los canalones. No accione las lamas en caso de helada o nieve.

Oviala

FR

Instructions d'installation
Pergola bioclimatique adossée
OIA taille 3x6m

EN

Assembly Instructions
Bioclimatical wall mounted
Pergola OIA size 3x6m

ES

Instrucciones de instalación
Pérgola bioclimática adosada
OIA tamaño 3x6m

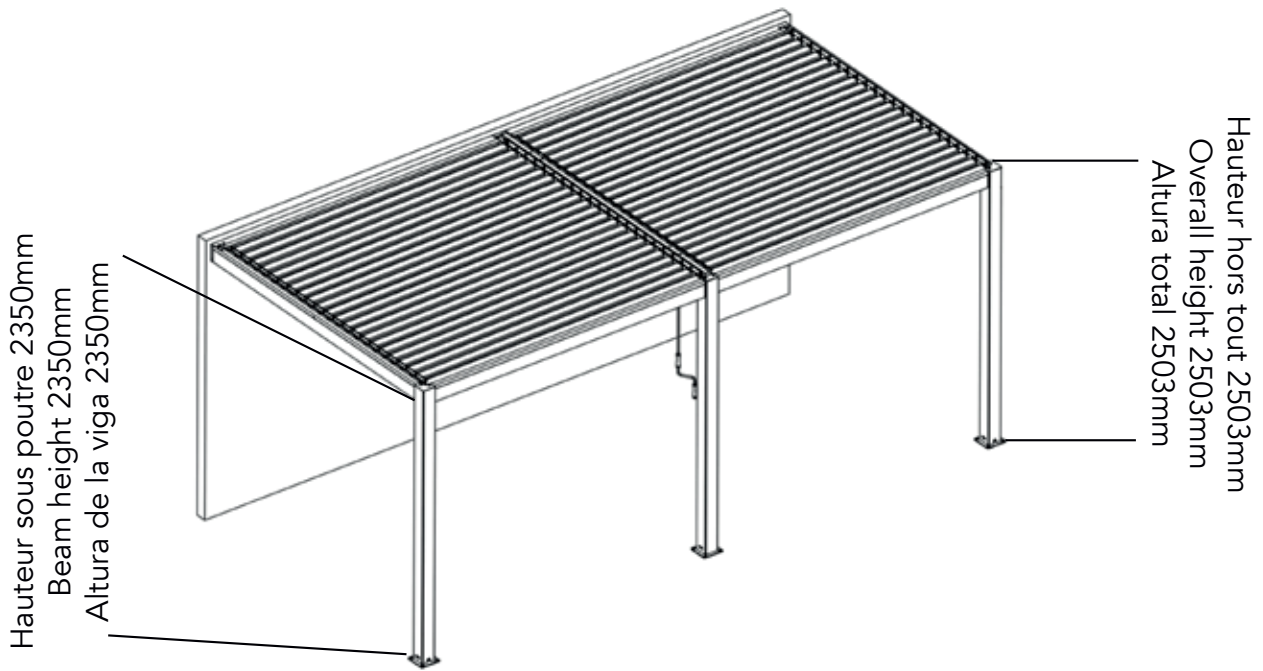

AVANT DE COMMENCER

1. Lire et étudier la notice de montage en entier
2. Repérer les pièces constituant la pergola
3. Regrouper et contrôler les différentes pièces et quincaillerie
4. Se munir de l'outillage nécessaire
5. Aménager une zone de montage dégagée
6. Ne jamais forcer les assemblages. Resserrer les vis après quelques temps d'usage.
7. Garder la notice de montage : si une pièce venait à manquer, elle vous permettra de le signaler au service après vente
8. Nous vous invitons à visionner la vidéo de montage disponible sur notre site internet Oviala.com pour vous aider à identifier les différentes étapes





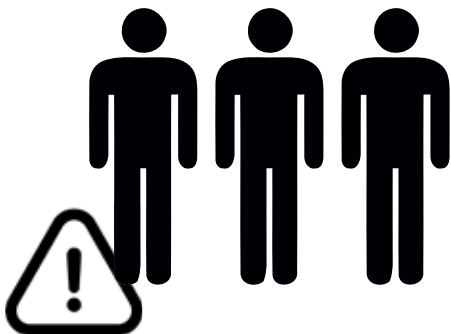

BEFORE STARTING

1. Read and study the entire manual
2. Locate the parts that make up the pergola
3. Grouping and checking the various parts and hardware
4. Provide the necessary tools
5. Provide a clear assembly area
6. Never force the connections. Tighten the screws after some time of use.
7. Keep the assembly instructions: if a part is missing, it will allow you to report it to the after-sales service
8. We invite you to watch the available video on our website Oviala.com to help you identify the different stages

ANTES DE EMPEZAR

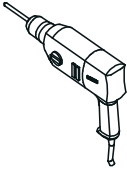
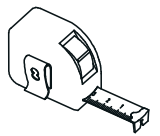
1. Leer y estudiar todo el manual
2. Localiza las piezas que componen la pérgola
3. Agrupar y comprobar las distintas piezas y herrajes
4. Proporcionar las herramientas necesarias
5. Proporcionar una zona de montaje despejada
6. Nunca fuerce las conexiones. Apriete los tornillos después de un tiempo de uso.
7. Conserve las instrucciones de montaje: si una pieza falta, le permitirá informar al el servicio posventa
8. Le invitamos a ver el vídeo del disponible en nuestro sitio web Oviala.com para ayudarle a identificar el diferentes etapas

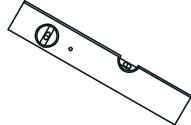





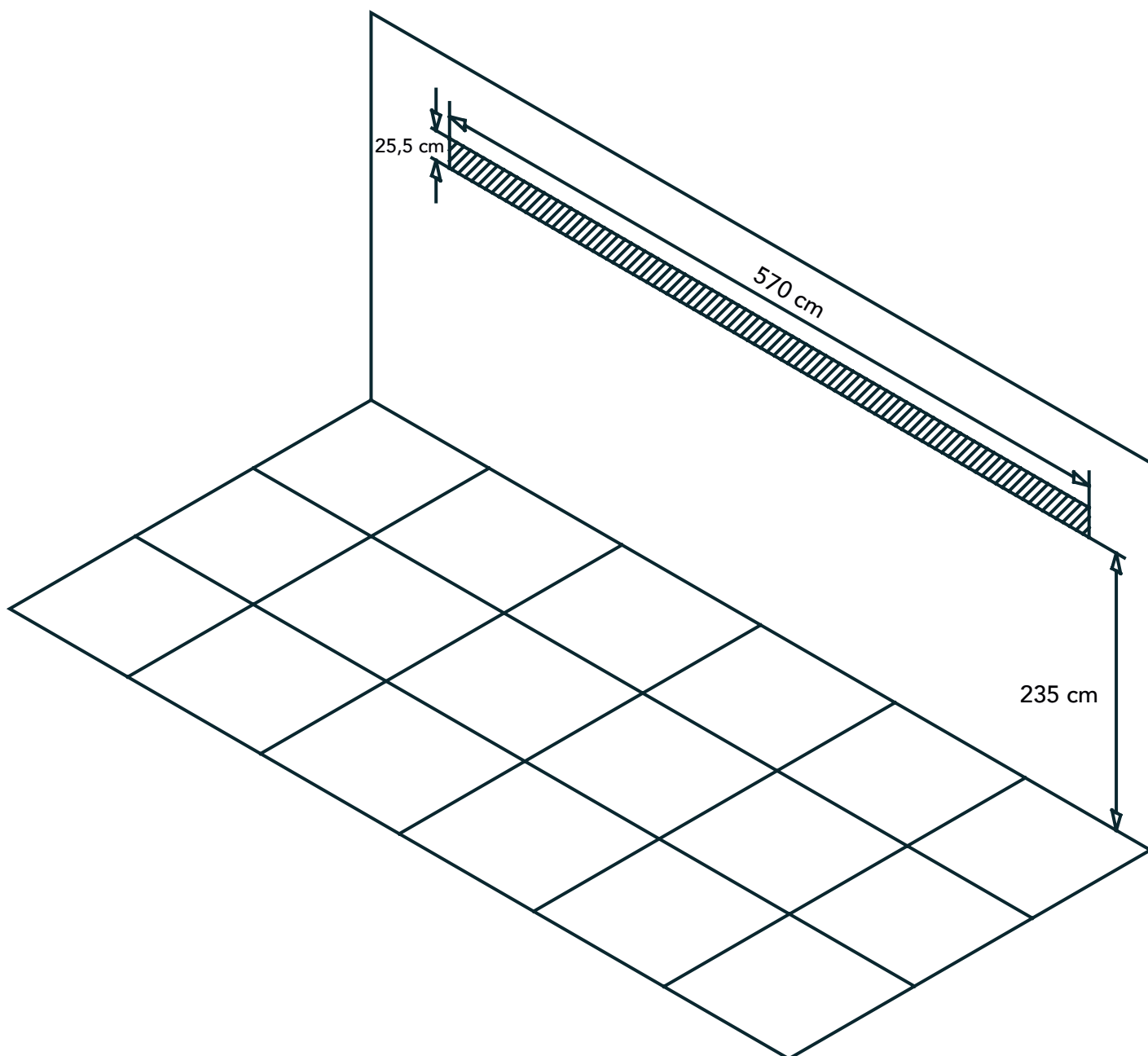











 x2	 16		
			

































FIXATION MURALE	WALL MOUNTING	MONTAJE EN PARED
<p>1. Assurez vous que le mur choisi pour l'installation soit parfaitement plan et qu'il ne présente pas de défaut structural (fissure, éclat...).</p> <p>2. Contrôlez que vous disposez bien de la place nécessaire à l'installation de la pergola en vous reportant au dimensions indiquées sur le dessin ci dessous</p> <p>3. Les chevilles fournies sont prévues pour une utilisation dans un mur en béton plein. Dans le cas d'un mur creux ou autre matériaux, nous vous recommandons d'adapter la fixation.</p>	<p>1. Make sure that the wall chosen for the installation is perfectly flat and that it has no structural defects (cracks, splinters, etc.).</p> <p>2. Check that you have enough space to install the pergola by referring to the dimensions shown on the drawing below</p> <p>3. The dowels supplied are designed for use in a solid concrete wall. In the case of a hollow wall or other materials, we recommend that you adapt the fixing.</p>	<p>1. Asegúrese de que la pared elegida para la instalación es perfectamente plana y que no tiene defectos estructurales (grietas, astillas, etc.).</p> <p>2. Compruebe que dispone de espacio suficiente para instalar la pérgola consultando las dimensiones indicadas en el siguiente dibujo</p> <p>3. Los tacos suministrados están diseñados para ser utilizados en un muro de hormigón sólido. En el caso de una pared hueca u otros materiales, se recomienda adaptar la fijación.</p>







CONSIGNES À OBSERVER	INSTRUCTIONS TO FOLLOW	INSTRUCCIONES A SEGUIR
<p>1. Installer la pergola par temps sec et sans vent.</p> <p>2. Trois personnes sont nécessaires pour le montage.</p> <p>3. Porter des gants de sécurité, des verres protecteurs et des vêtements à manches longues pendant toute la durée d'installation. Afin d'éviter toute blessure, faire attention aux angles vifs de quelques éléments.</p> <p>4. Tenir les enfants à l'écart du lieu de montage.</p> <p>5. Ne pas s'appuyer sur la pergola durant la phase de montage.</p> <p>6. Contrôler les aplombs et les niveaux.</p> <p>7. Ne pas grimper ni se tenir debout sur les lames orientables, en raison du risque de chute.</p>	<p>1. Install the pergola in dry and windless weather.</p> <p>2. Three people are needed for the installation.</p> <p>3. Wear safety gloves, safety glasses and long-sleeved clothing during the entire installation process. To avoid injury, pay attention to the sharp edges of some elements.</p> <p>4. Keep children away from the installation area.</p> <p>5. Do not lean on the pergola during the installation phase.</p> <p>6. Check that the posts are level and plumb.</p> <p>7. Do not climb or stand on the adjustable slats, as there is a risk of falling.</p>	<p>1. Instale la pérgola con tiempo seco y sin viento.</p> <p>2. Se necesitan tres personas para la instalación.</p> <p>3. Utilice guantes de seguridad, gafas de seguridad y ropa de manga larga durante todo el proceso de instalación. Para evitar lesiones, preste atención a los bordes afilados de algunos elementos.</p> <p>4. Mantenga a los niños alejados de la zona de instalación.</p> <p>5. No se apoye en la pérgola durante la fase de instalación.</p> <p>6. Compruebe que los postes están nivelados y a plomo.</p> <p>7. No se suba ni se ponga de pie sobre las planchas ajustables, ya que existe riesgo de caída.</p>

LISTE PIÈCES ET QUINCAILLERIE	PARTS LIST AND HARDWARE	LISTA DE PIEZAS Y HARDWARE
-------------------------------	-------------------------	----------------------------

1		x12	13		x6
2		x2	14		x4
3		x3	15		x6
4		x2	16		x2
5		x2			
6		x116			
7		x92			
8		x92			
9		x2			
10		x24			
11		x2			
12		x2			

A1		x1	E2			x1	
A2		x1	F1			x1	
B1		x1	F2			x1	
B2		x1	F3			x1	
C1		x1	F4			x1	
C2		x1	D1			x1	
C3		x1	D2			x1	
E1			x1	D3			x1
				Gx			40
				Hx			2
				Ix			2
				Jx			4

<p>Étape 1 : Montage des platines sur les poteaux. Retirer les vis présentes sur les hauts des poteaux pour préparer l'étape suivante</p>	<p>Step 1 : Assembling bases on posts. Please remove the screws at the top of the posts to prepare the next step</p>	<p>Paso 1 : Montaje de las bases en los postes. Por favor, retire los tornillos en la parte superior de los postes para preparar el siguiente paso</p>
--	---	---



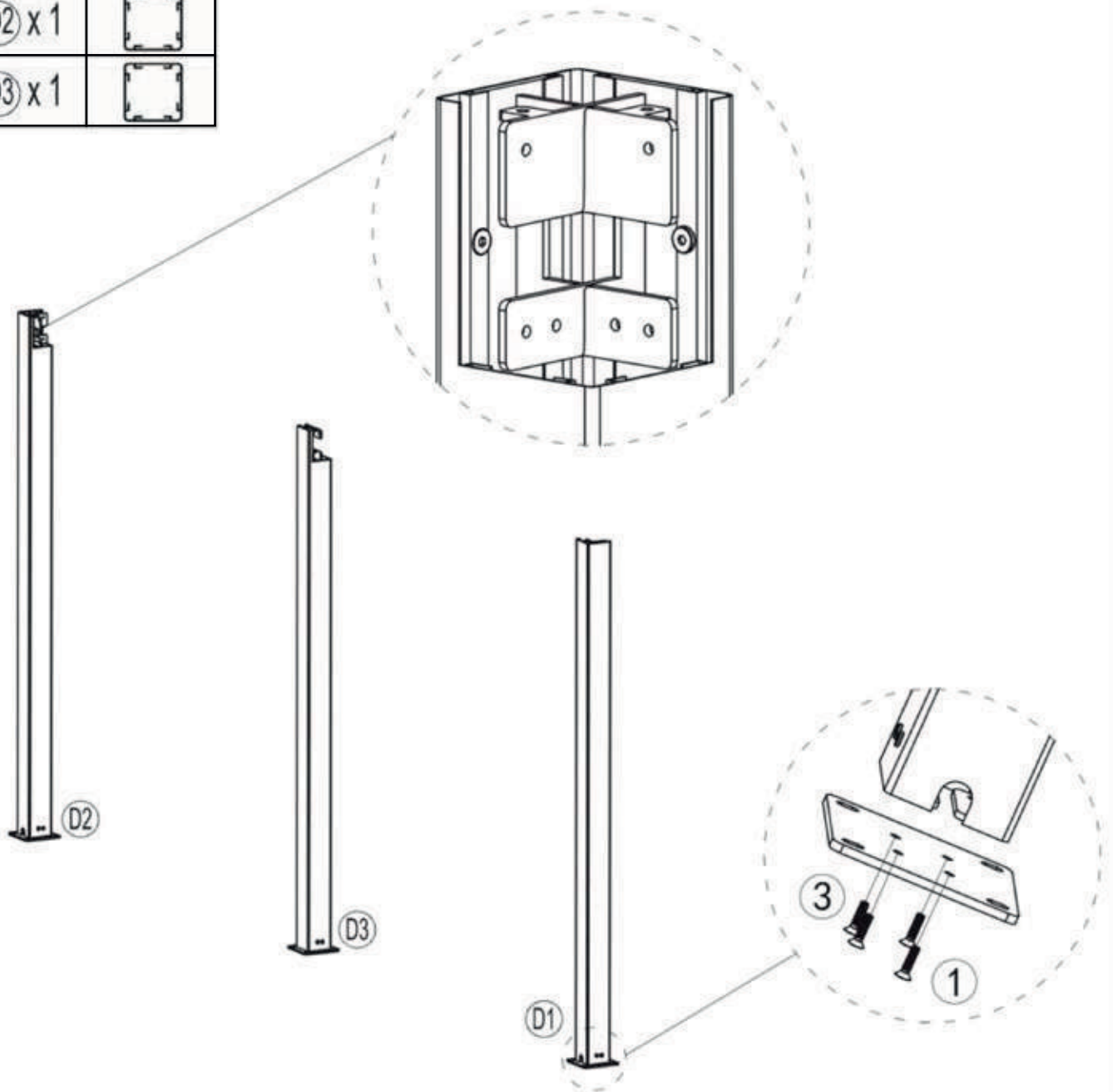

① x 12	
③ x 3	
D1 x 1	
D2 x 1	
D3 x 1	



Étape 2 :
Assemblage des poteaux
sur la traverse simple

Step 2 :
Assembling the posts
to the simple crossbeam

Paso 2 :
Montaje de los postes en el
travesaño simple



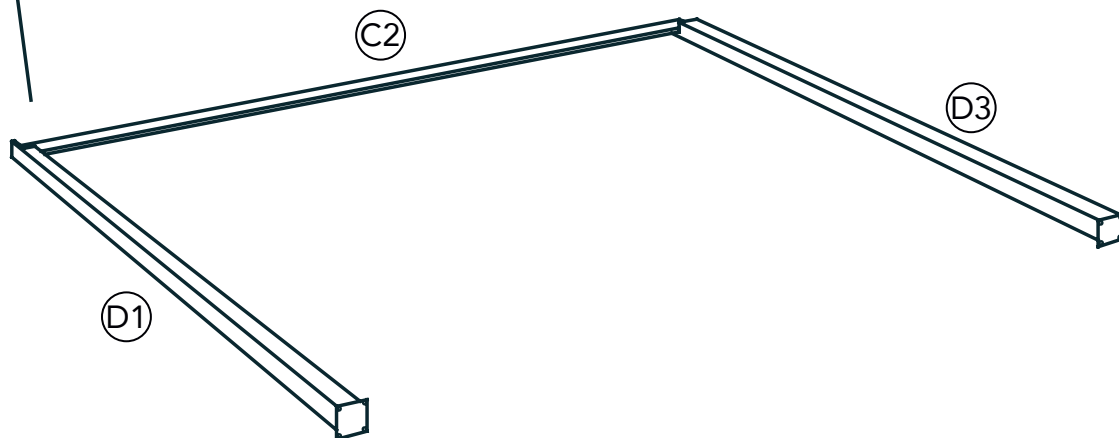
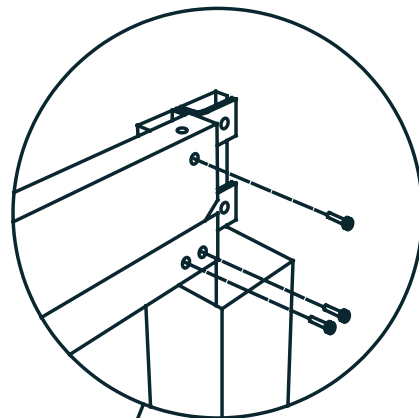
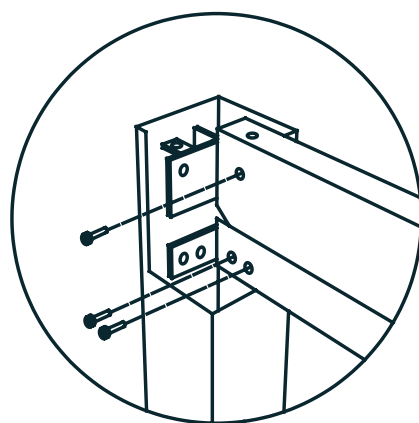

⑥ x6	
① x1	
③ x1	
② x1	



Étape 4 :
Installation de la traverse murale à encoches

Step 4 :
Wall cross beam mounting

Paso 4 :
Instalación del larguero mural

(15) x4		
		M8X16
(B1) x1		
(B2) x1		

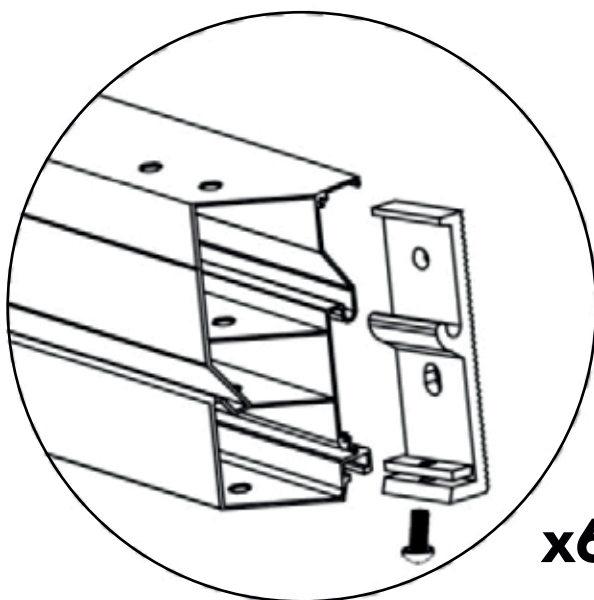
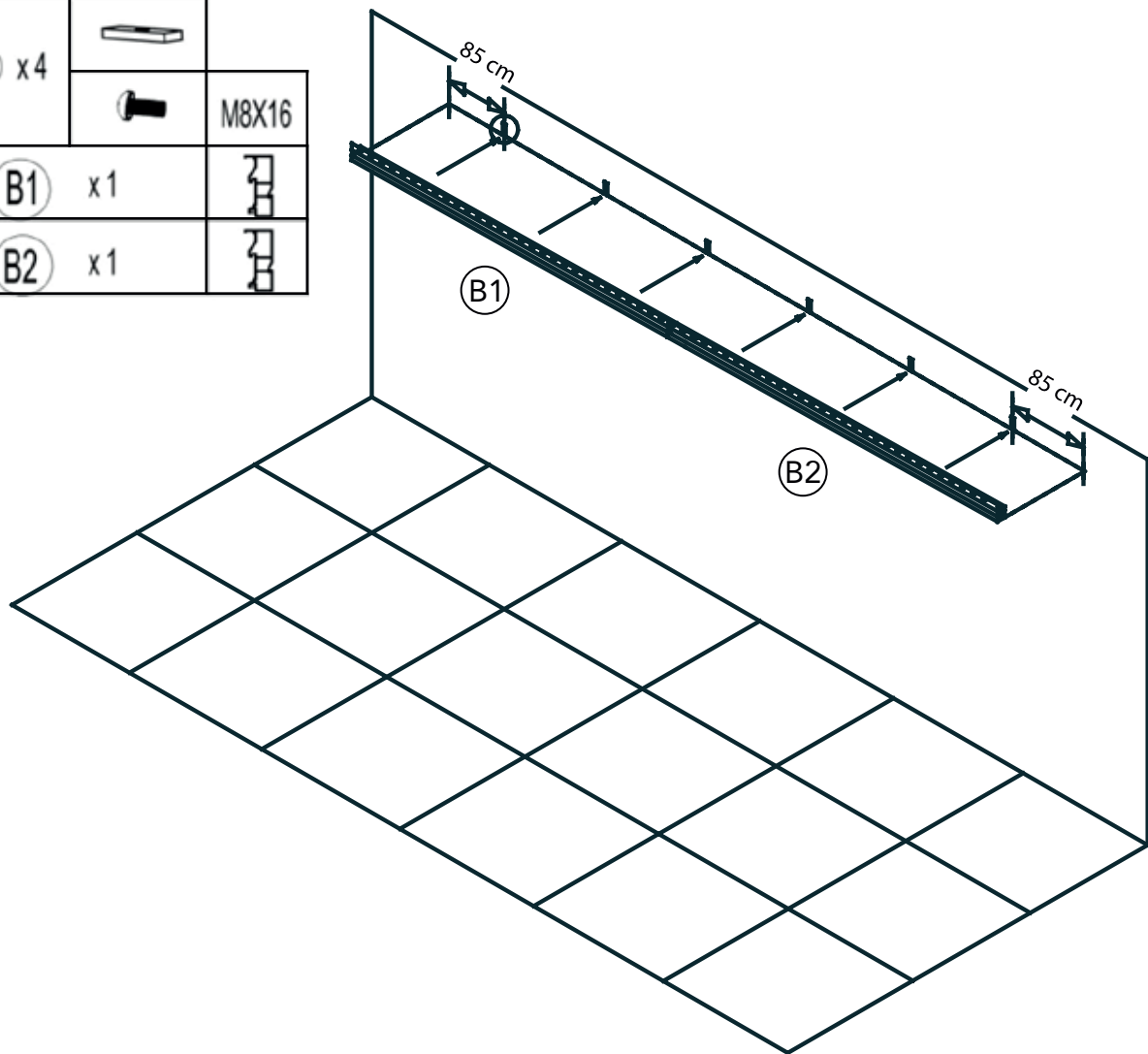

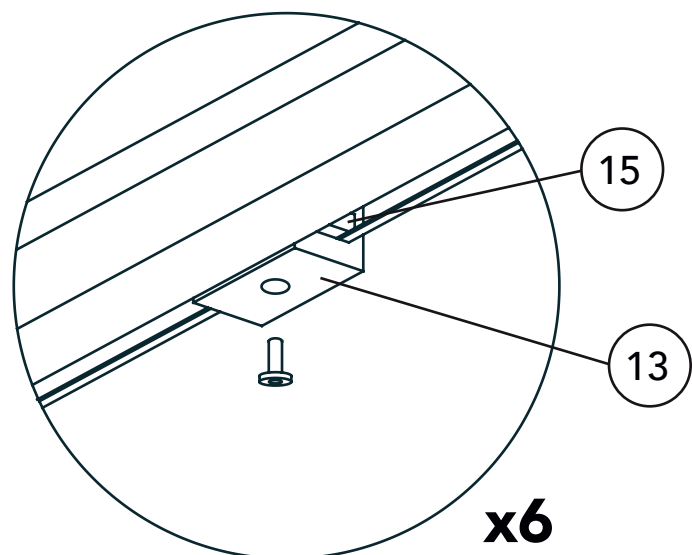

x6



x6

<p>Étape 5 : Installation des équerres sur la traverse murale</p>	<p>Step 5 : Scare assembly on the wall cross beam</p>	<p>Paso 5 : Montaje del miedo en la viga transversal de la pared</p>
--	--	---

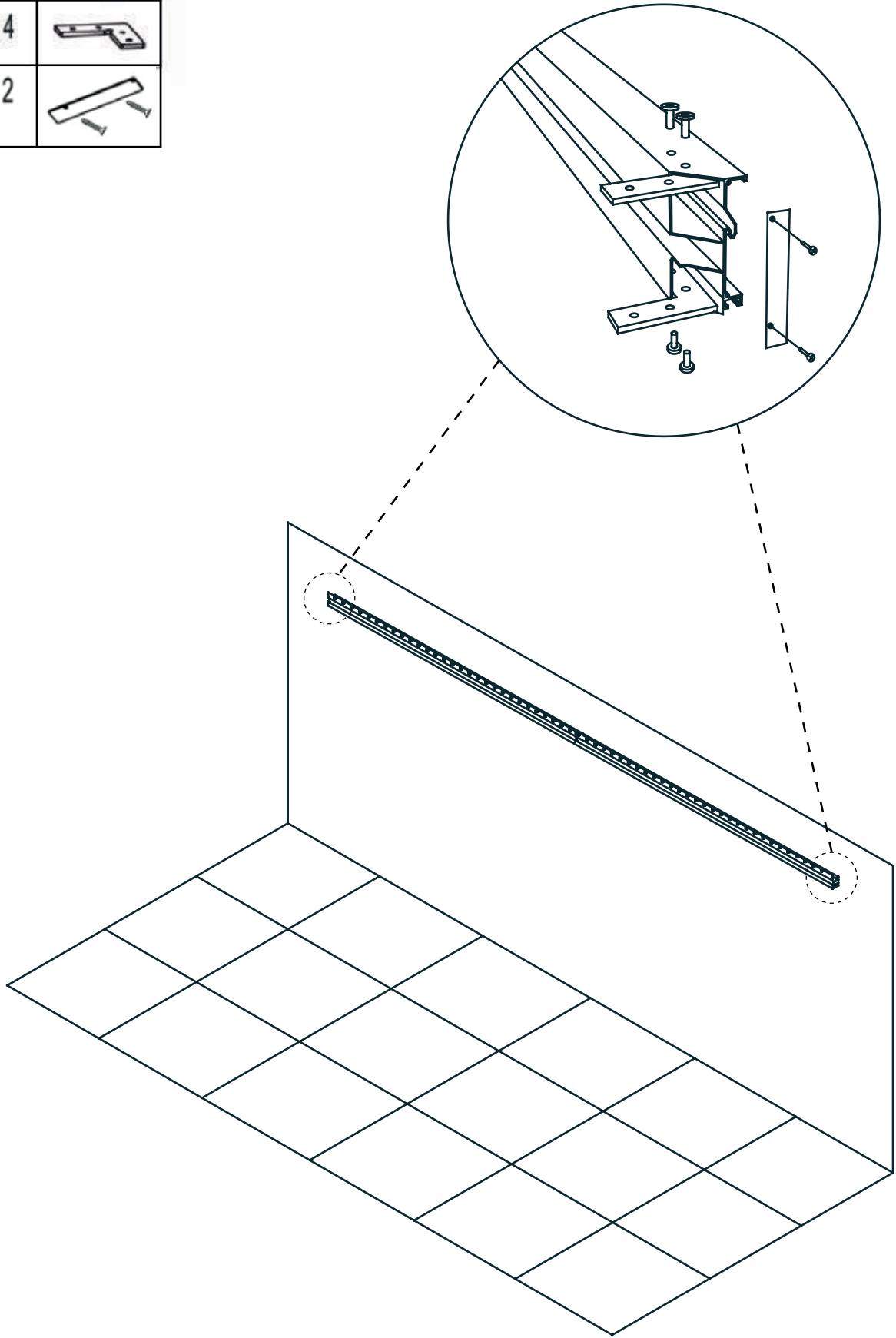

<p>⑥ x 8</p>	
<p>⑭ x 4</p>	
<p>⑰ x 2</p>	



Étape 6 :
Assemblage des
traverses à encoches

Step 6 :
Assembly of the notched
crossbeams

Paso 6 :
Montaje de los travesaños
travesaños

6	x13	
A2	x1	
C3	x1	

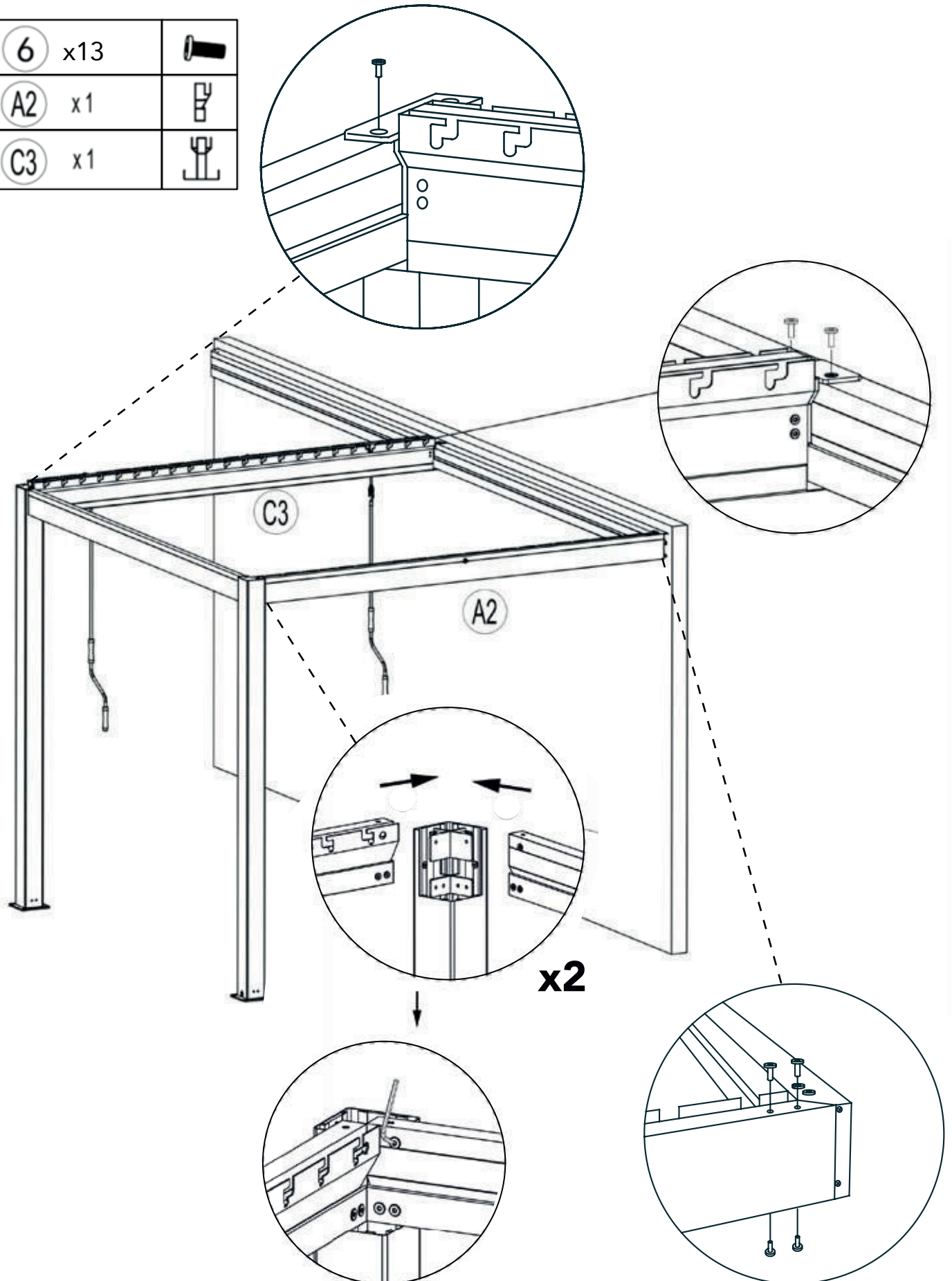

Étape 7 :
Assemblage du reste de
la structure

Step 7 :
Assembling of the rest of
the structure

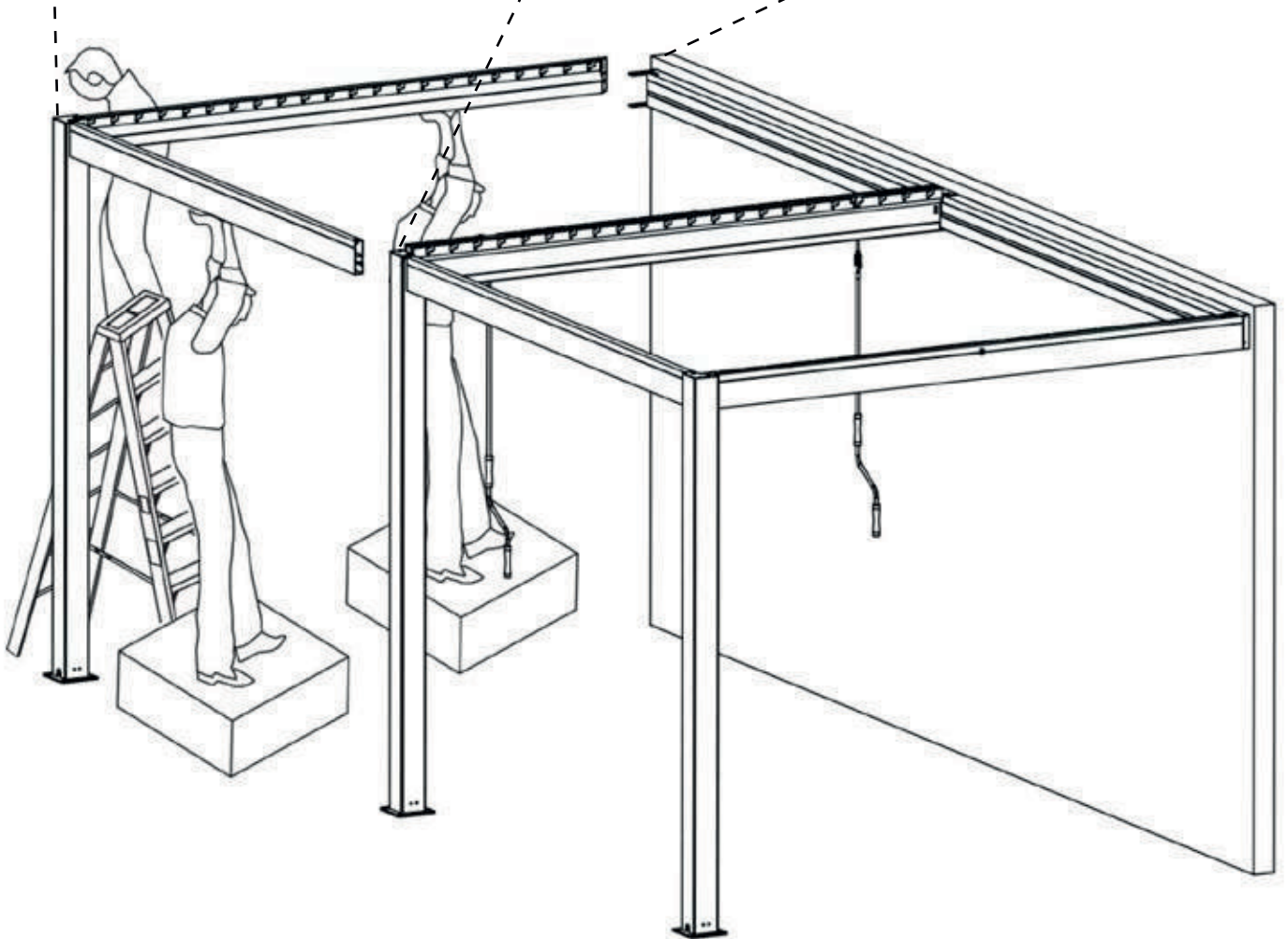
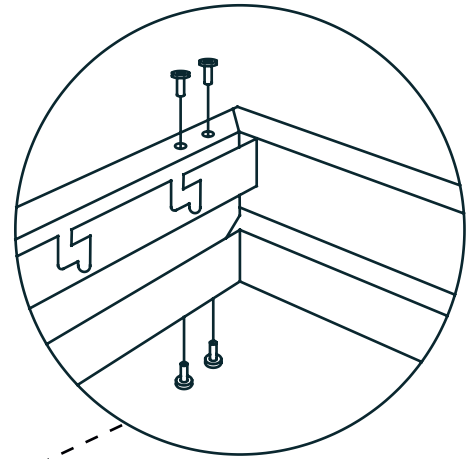
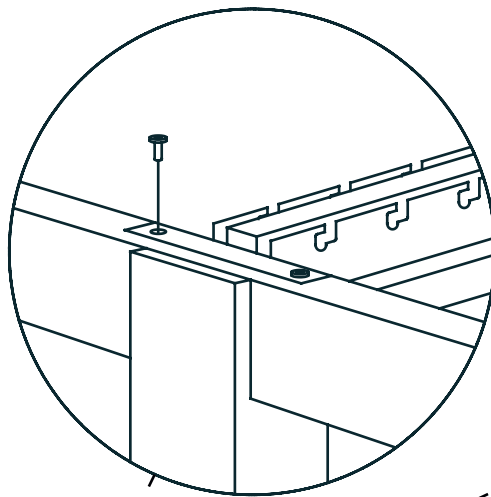
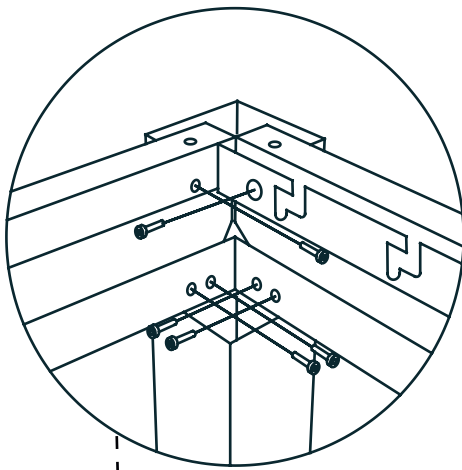
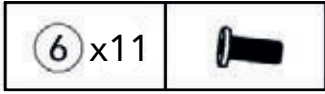

Paso 7 :
Montaje del resto de
la estructura



Étape 8 :
Assemblage des couvercles
sur les poteaux





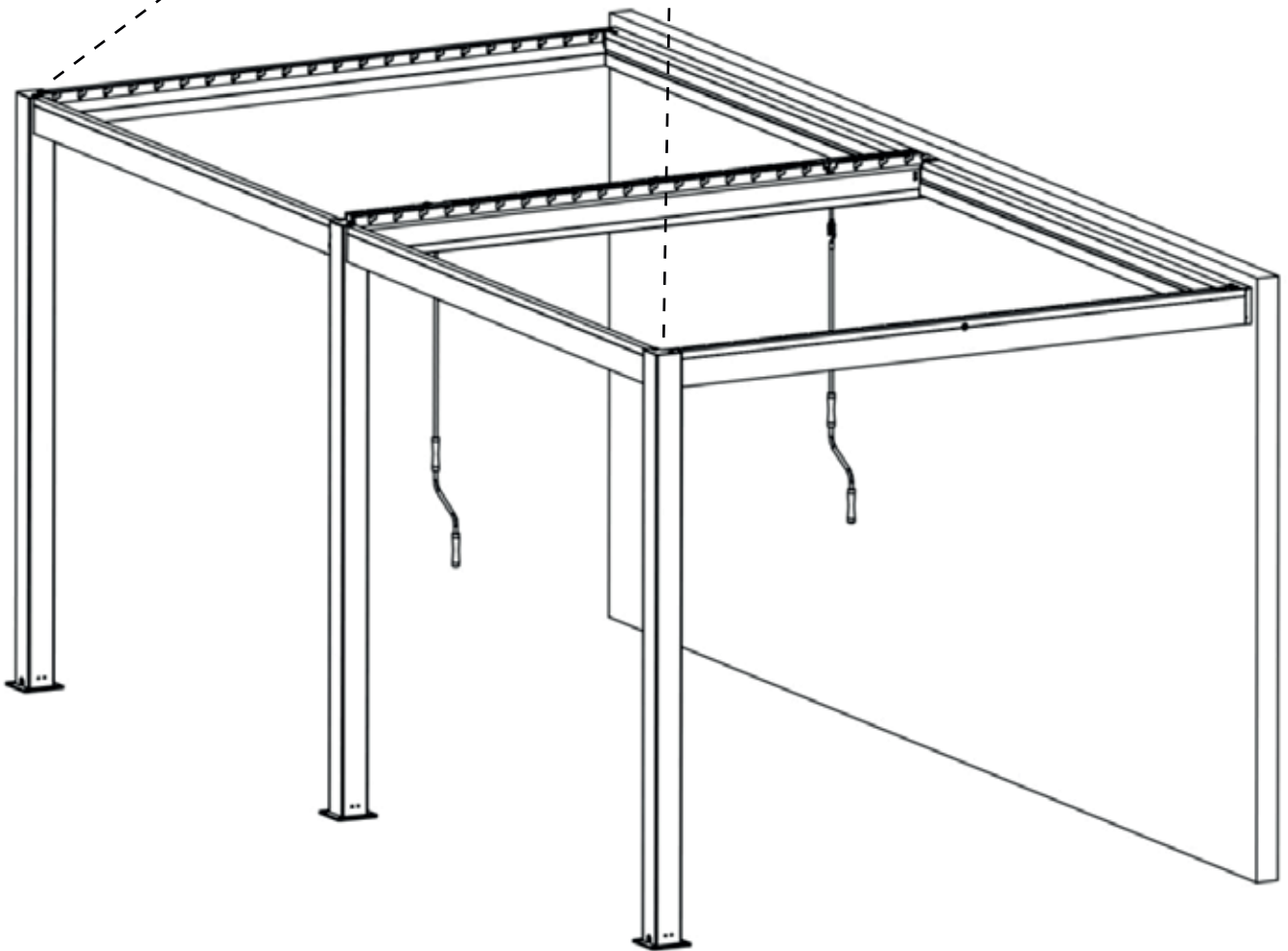
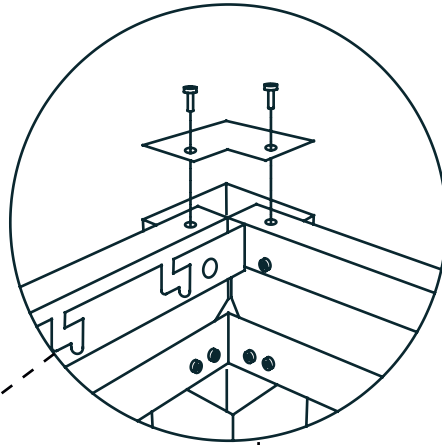

Step 8 :
Assembling the covers
on the posts

Paso 8 :
Montaje de las cubiertas
en los puestos

6 x4	
4 x2	



Étape 9 : Assemblage des gouttières	Step 9 : Assembling of the gutters	Paso 9 : Montaje de los canalones
--	---	--



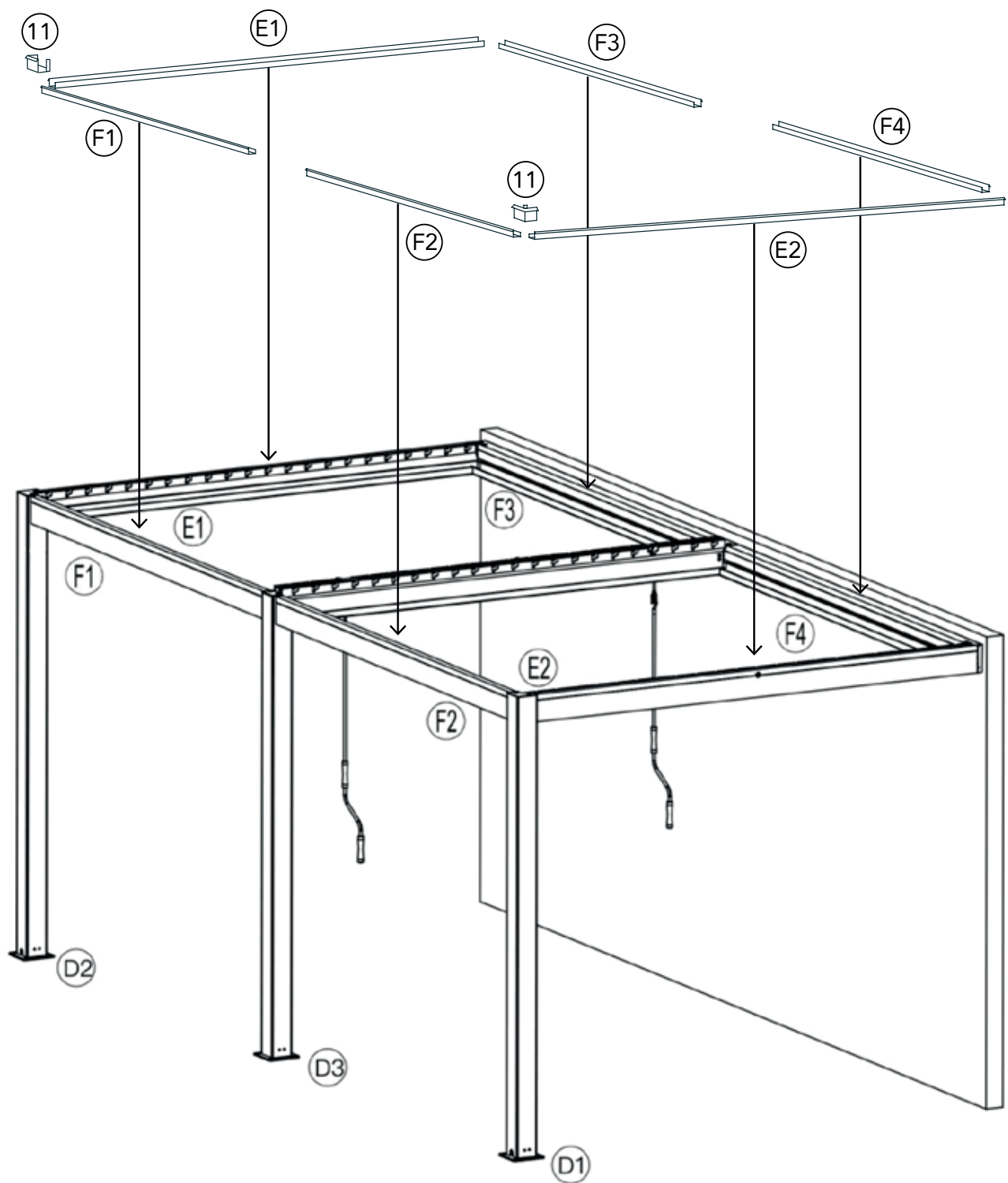

ⓔ1 x1		ⓔ2 x1		Ⓜ11 x2	
ⓕ1 x1		ⓕ2 x1			
ⓕ3 x1		ⓕ4 x1			



**Étape 10 :
Montage des lattes**

**Step 10 :
Assembling of the slats**

**Paso 10 :
Montaje de las lamas**

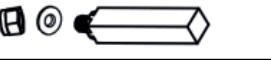

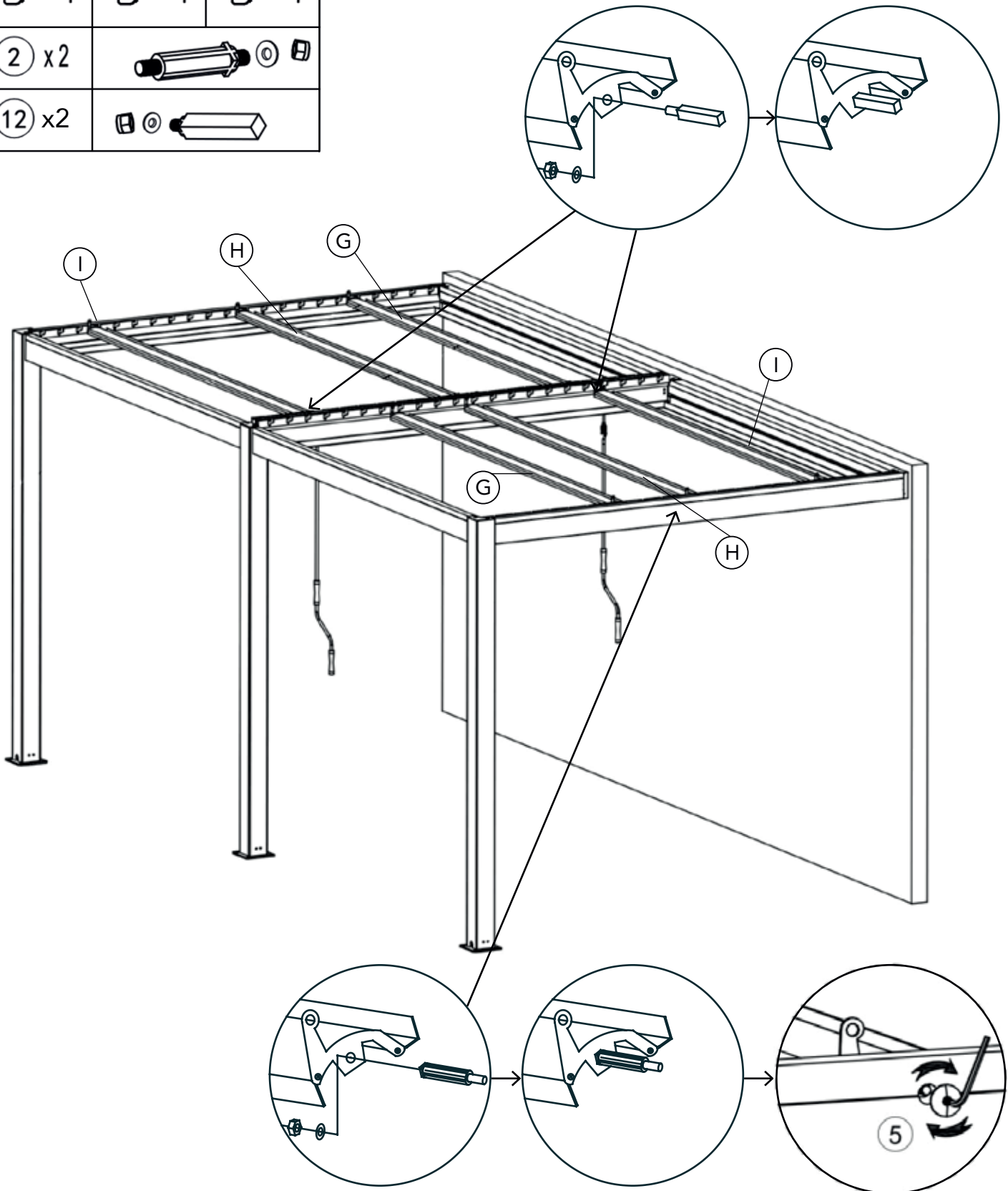

⑤ x2		
⑥ x40	⑦ x2	⑧ x2
		
② x2		
⑫ x2		



Étape 11 :
Montage des profils en L

Step 11 :
Assembling of the L profiles

Paso 11 :
Montaje de los perfiles L

⑥ x92	⑦ x92	⑧ x92	ⓐ x4
			



FR: Ne pas serrer les écrous ⑧ à fond, les lames doivent pouvoir pivoter facilement.
EN: Do not tighten nuts ⑧ all the way, the louvers must be able to turn easily.
ES: No apriete demasiado las tuercas ⑧, ya que los listones deben pivotar con facilidad.

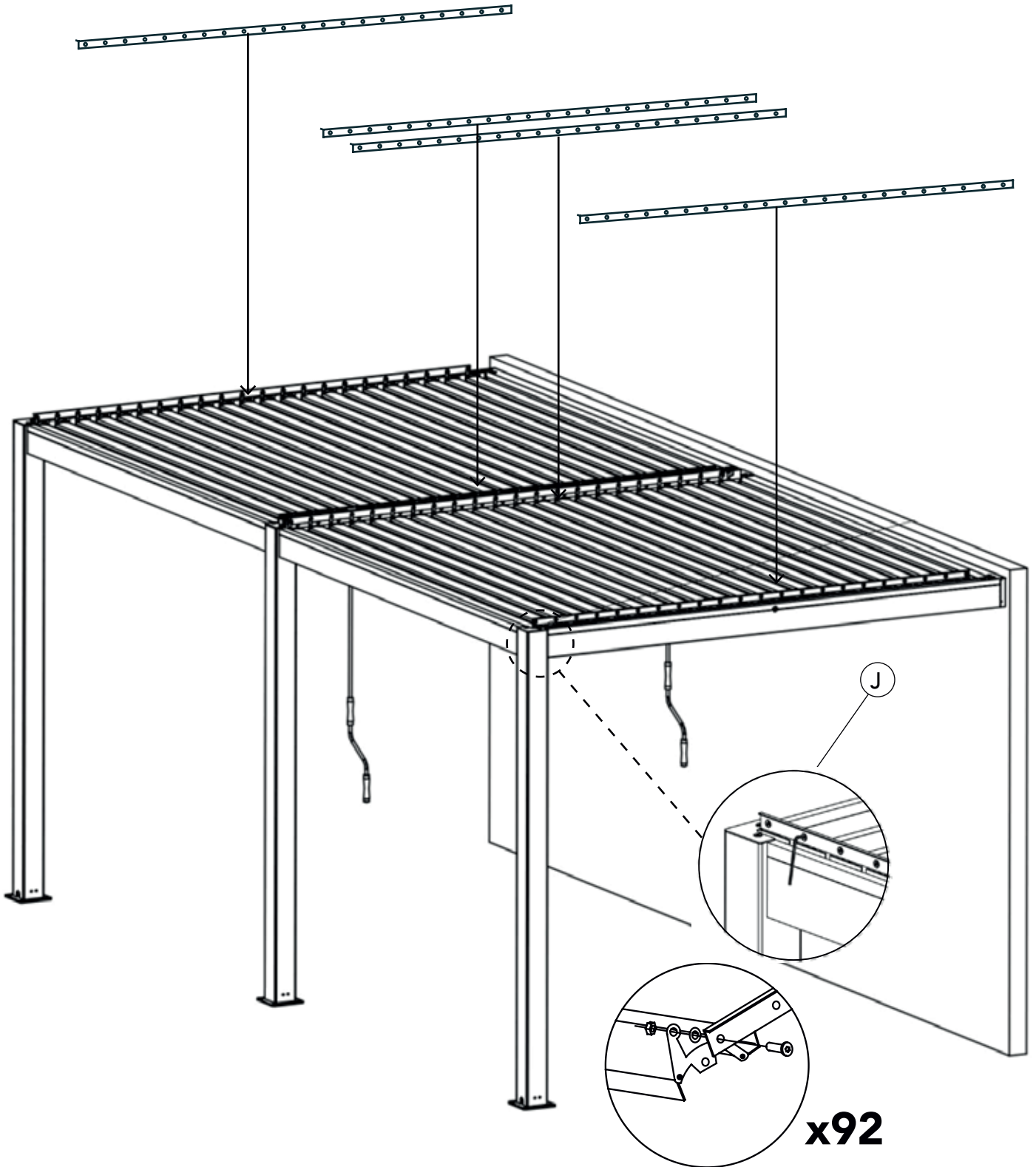

**Étape 12 :
Fixation au sol**

Positionner les pieds de la pergola à l'endroit désiré en respectant les dimensions ci dessous.

Les chevilles fournies sont exclusivement destinées à un sol en béton. Pour un autre type de sol veuillez utiliser un mode de fixation adapté.

**Step 12 :
Floor fixation**

Position the legs of the pergola in the desired location, respecting the dimensions below.

The dowels supplied are only suitable for concrete floors. For other types of floor, please use a suitable fixing method.

**Paso 12 :
Montaje de las lamas**

Coloque las patas de la pérgola en el lugar deseado, respetando las dimensiones indicadas a continuación.

Los tacos suministrados sólo son adecuados para suelos de hormigón. Para otros tipos de suelo, utilice un método de fijación adecuado.

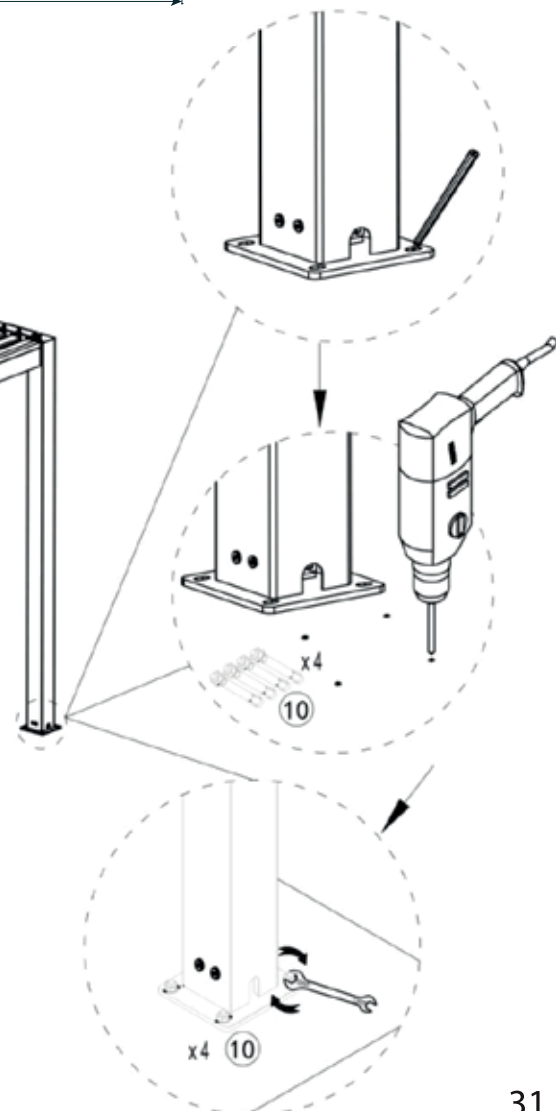
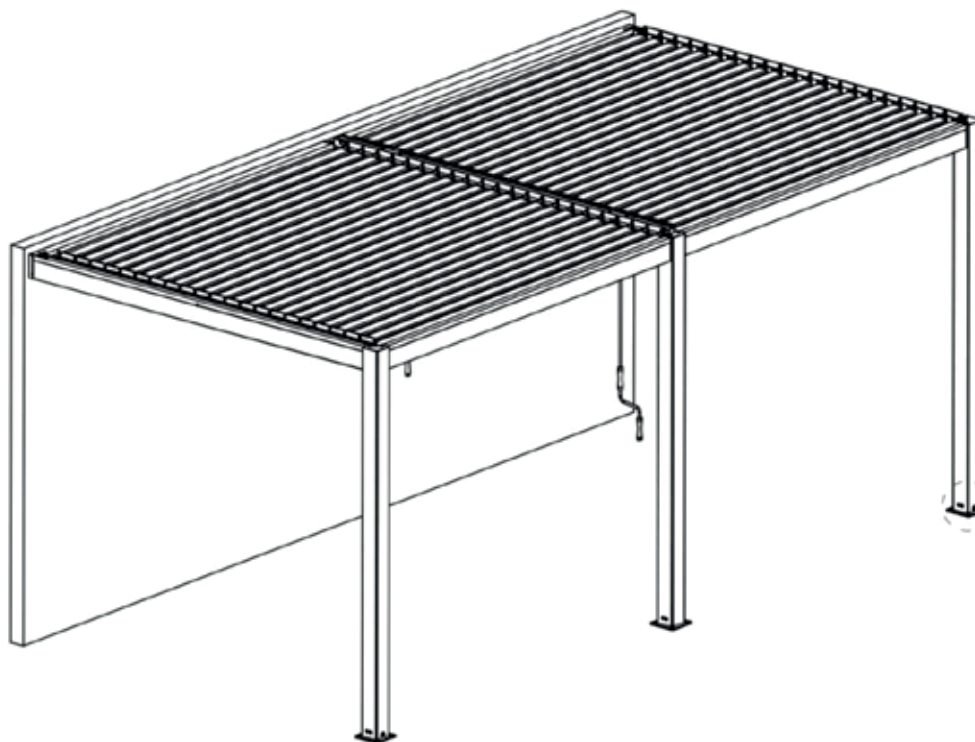
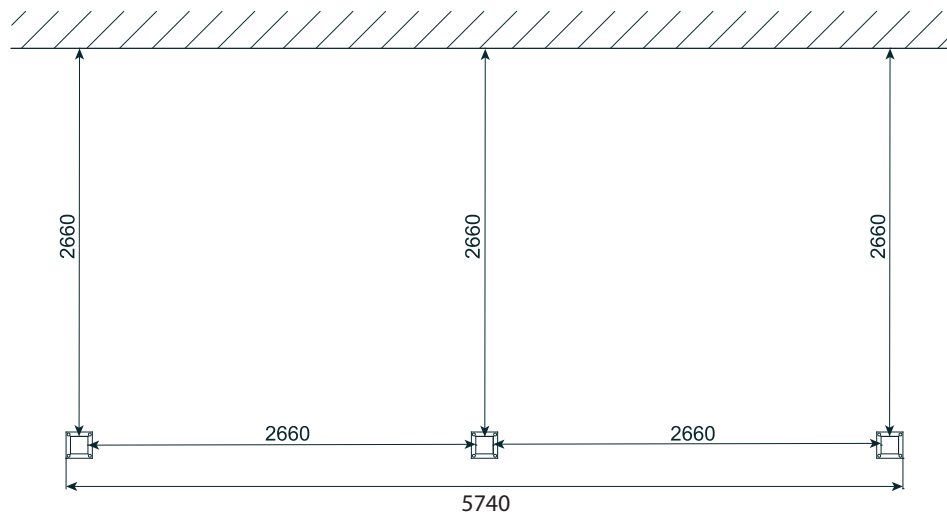

FR GARANTIE :

Votre pergola est garantie 2 ans, sauf pour les pièces d'usure telles que le système de manoeuvre et les joints des lames.

Votre garantie couvre les défauts de fabrication et les vices cachés.

Pour en bénéficier votre pergola doit :

- Etre posée conformément à la notice
- Etre entretenue régulièrement
- Etre utilisée normalement et sans avoir subi de modifications

Facteurs d'exclusion de la garantie :

- Le non-respect des conditions citées ci-dessus
- Les défauts apparents non signalés avant la mise en oeuvre du produit
- Les détériorations consécutives au montage ou à une mauvaise utilisation
- Les dommages causés par un événement extérieur.

Mise en oeuvre de la garantie :

- La garantie est limitée au remplacement des pièces défectueuses, à l'exclusion de la réparation de tout autre préjudice
- Voir avec votre point de vente :
 - Les éléments d'achats (facture, numéro commande d'origine)
 - Une description du problème
 - Des photos facilitant la compréhension

CONDITIONS D'UTILISATION:

Nos pergolas bioclimatiques sont des produits entièrement démontables et temporaires, elles n'entrent pas dans la catégorie des ouvrages permanents. Elles sont conçues pour un usage domestique et en aucun cas pour une utilisation en collectivité, elles ne sont pas soumises à la réglementation des ouvrages recevant du public. Toute utilisation d'appareil chauffant (barbecue, plancha, chauffage d'extérieur) sous ou à proximité de la pergola est interdite. En cas de vent ou de chute de neige, il est recommandé de laisser les lames ouvertes. L'épaisseur de la neige ne doit jamais excéder une épaisseur de 10cm, déblayer si nécessaire. En cas de phénomène météorologique exceptionnel ou de vent violent (plus de 90km/h), la pergola doit être démontée et rangée à l'abri.

ENTRETIEN :

Pour conserver son aspect d'origine nettoyer régulièrement à l'aide d'un chiffon humide, du savon et de l'eau tiède. Ne pas utiliser de détergents agressifs ou abrasifs. Il est normal de constater une légère alteration de la couleur avec le temps et l'usage.

MAINTENANCE :

Vérifier le serrage des vis une fois par an. S'assurer régulièrement que rien n'obstrue l'évacuation de l'eau dans les gouttières. Ne pas actionner les lames en cas de gel ou de neige. La pergola n'assure pas une étanchéité parfaite, en cas de fortes précipitations, il est possible que de l'eau traverse le toit de la pergola.

EN GUARANTEE :

Your pergola is guaranteed for 2 years, except for parts subject to wear and tear such as the operating system and the slat seals.

Your guarantee covers manufacturing defects and hidden faults.

To benefit from this guarantee your pergola must :

- Be installed in accordance with the instructions
- Be regularly maintained
- Be used normally and not have been modified

Factors excluding the guarantee :

- Failure to comply with the above conditions
- Apparent defects not reported before the product is used
- Damage caused by assembly or misuse
- Damage caused by an external event.

Implementation of the guarantee :

- The warranty is limited to the replacement of defective parts, to the exclusion of compensation for any other damage
- See your point of sale:
 - Purchase details (invoice, original order number)
 - A description of the problem
 - Photos to help you understand the problem

CONDITIONS OF USE:

Our bioclimatic pergolas are entirely removable and temporary products, they do not fall into the category of permanent structures. They are designed for domestic use and in no case for use in a community, they are not subject to the regulations for structures receiving the public. Any use of heating equipment (barbecue, plancha, outdoor heating) under or near the pergola is prohibited. In the event of wind or snowfall, it is recommended that the slats are left open. The snow should never be more than 10cm deep and should be cleared away if necessary. In the event of exceptional weather conditions or strong winds (over 90km/h), the pergola must be dismantled and stored under cover.

CLEANING :

To maintain its original appearance clean regularly with a damp cloth, soap and warm water. Do not use aggressive or abrasive detergents. It is normal to notice a slight alteration of the colour with time and use.

MAINTENANCE :

Check the tightness of the screws once a year. Regularly check that there are no obstructions in the gutters. Do not operate the slats in case of frost or snow.

ES GUARANTEE :

Su pérgola está garantizada durante 2 años, excepto las piezas sujetas a desgaste, como el sistema de funcionamiento y las juntas de las lamas.

Su garantía cubre los defectos de fabricación y los vicios ocultos.

Para beneficiarse de esta garantía, su pérgola debe :

- Ser instalado de acuerdo con las instrucciones
- Ser mantenido regularmente
- Ser utilizado normalmente y sin haber sufrido ninguna modificación

Factores que excluyen la garantía :

- Incumplimiento de las condiciones anteriores
- Defectos aparentes no comunicados antes de la utilización del producto
- Daños causados por el montaje o el mal uso
- Daños causados por un evento externo.

Aplicación de la garantía :

- La garantía se limita a la sustitución de las piezas defectuosas, con exclusión de la indemnización por cualquier otro daño
- Vea su punto de venta:
 - Detalles de la compra (factura, número de pedido original)
 - Una descripción del problema
 - Fotos para ayudarle a entender el problema

CONDICIONES DE USO:

Nuestras pérgolas bioclimáticas son productos totalmente desmontables y temporales, no entran en la categoría de estructuras permanentes. Están diseñadas para uso doméstico y en ningún caso para uso en una comunidad, no están sujetas a la normativa para estructuras que reciben al público. Se prohíbe el uso de equipos de calefacción (barbacoa, plancha, calefacción exterior) debajo o cerca de la pérgola. En caso de viento o nevadas, se recomienda dejar las lamas abiertas. La nieve nunca debe tener más de 10 cm de profundidad y debe retirarse si es necesario. En caso de condiciones meteorológicas excepcionales o de vientos fuertes (más de 90 km/h), la pérgola debe desmontarse y guardarse a cubierto.

LIMPIEZA :

Para mantener su aspecto original limpie regularmente con un paño húmedo, jabón y agua tibia. No utilice detergents agresivos o abrasivos. Es normal notar una ligera alteración del color con el tiempo y el uso.

MANTENIMIENTO :

Compruebe el apriete de los tornillos una vez al año. Compruebe regularmente que no hay obstrucciones en los canalones. No accione las lamas en caso de helada o nieve.

Oviala

FR

Instructions d'installation
Store pour pergola
bioclimatique
KAVALA/THEBES/ATHENES/OIA

EN

Installation instructions
Awnings for bioclimatic pergola
KAVALA/THEBES/ATHENES/OIA

ES

Instrucciones de instalación
Toldos para pérgola
bioclimática
KAVALA/THEBES/ATHENES/OIA

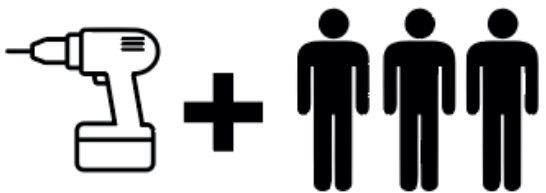
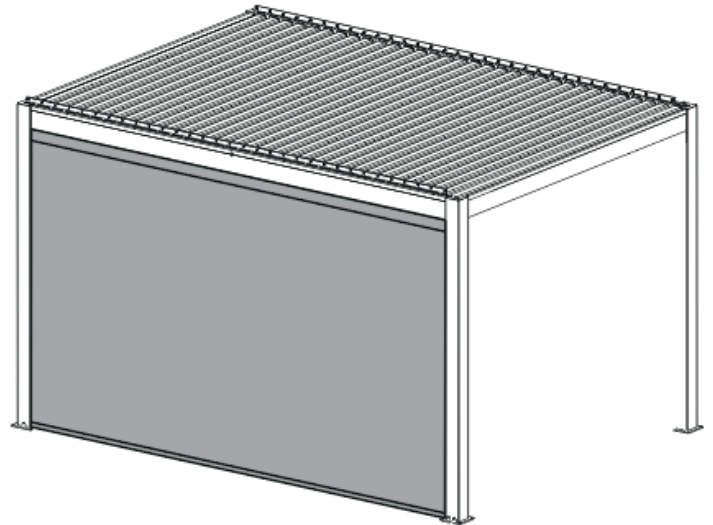
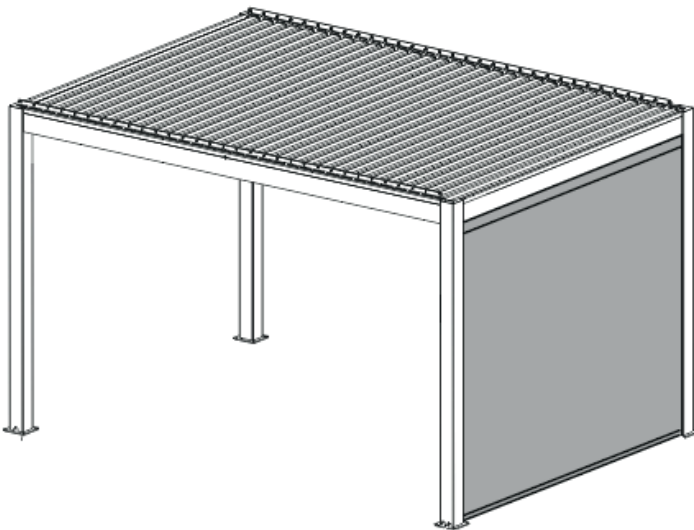

FR Laisser le store fermé quand le vent dépasse les 25 km/h.
EN Leave the awning closed when the wind exceeds 25km/h.
ES Dejar el todo cerrado cuando el viento exceda 25km/h.

A		x1
B		x2
C		x2
D		x2
E		x6

ETAPE 1

STEP 1

PASO 1

FR

Percer des trous de Ø5 à travers le profil B et le pied de la pergola

EN

Drill Ø5 holes through the B-profile and the pole of the pergola

ES

Taladre agujeros de Ø5 a través del perfil B y el mástil de la pérgola

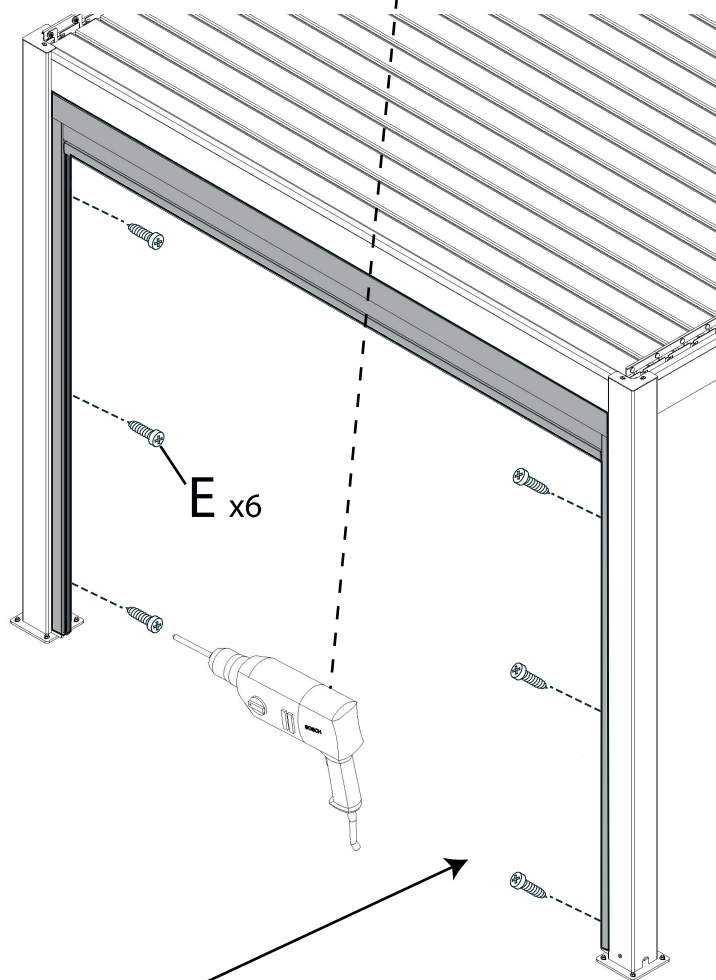
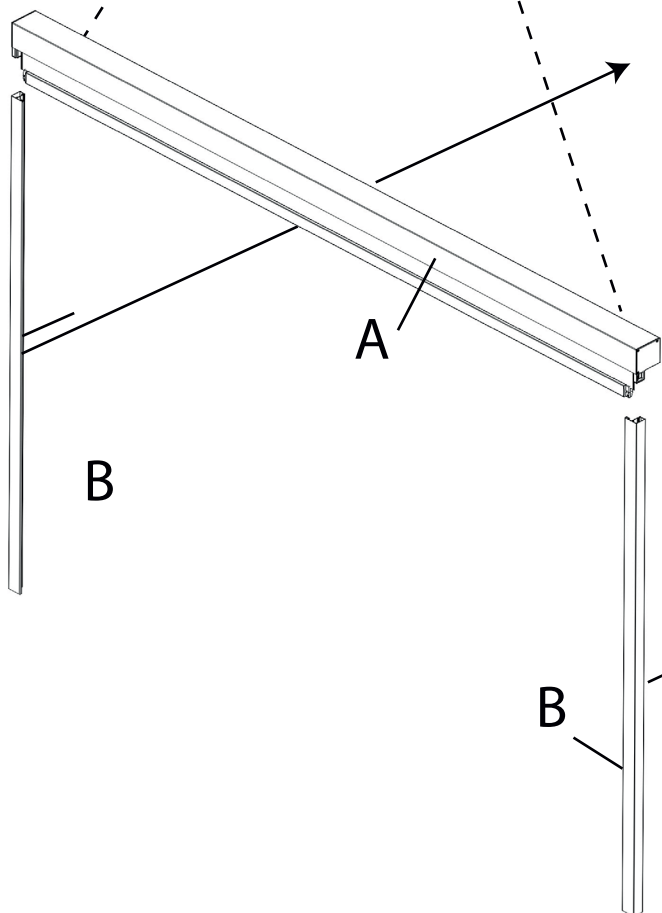
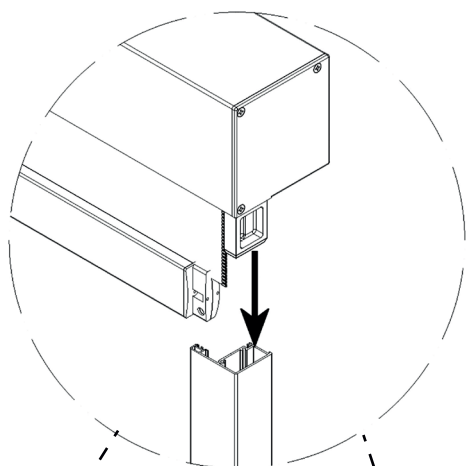

ETAPE 2
STEP 2
PASO 2

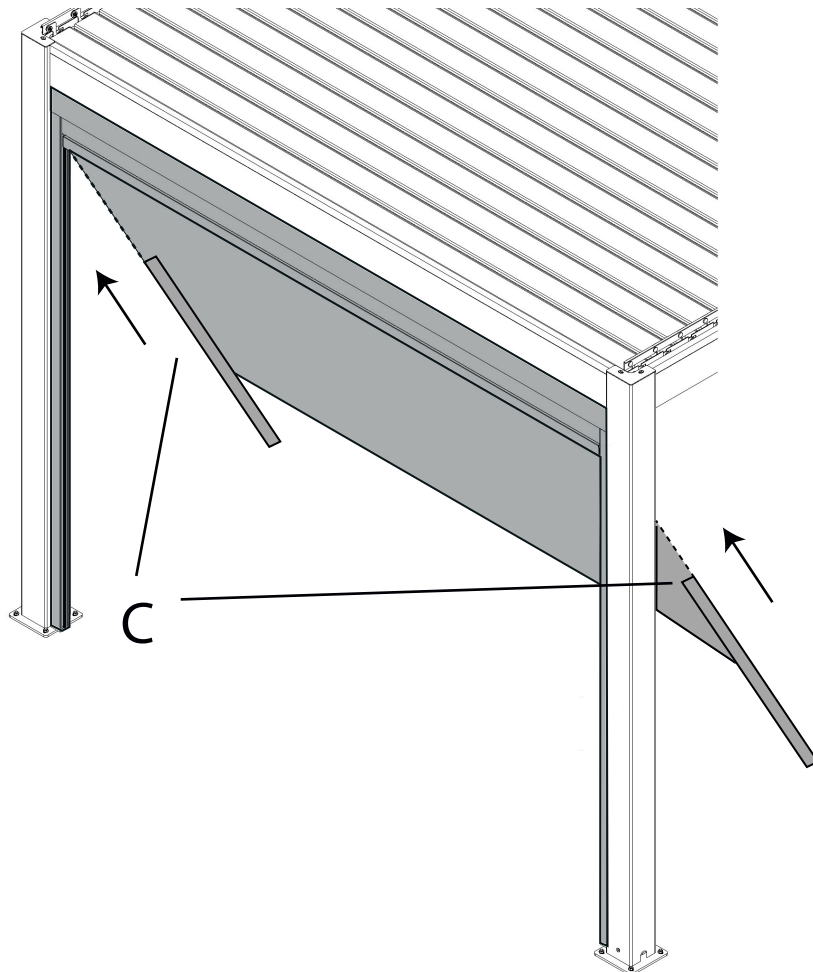
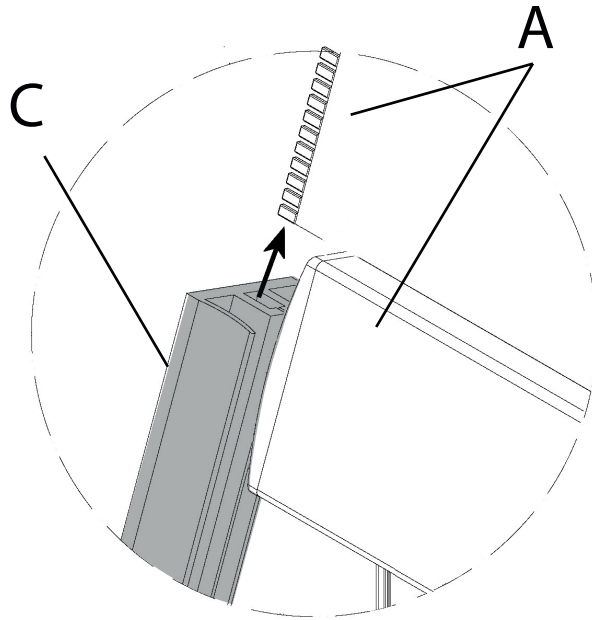

ETAPE 3
STEP 3
PASO 3

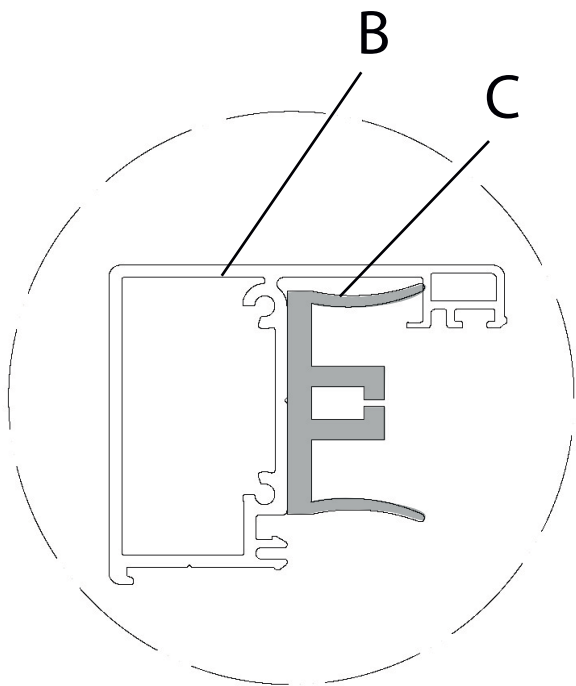
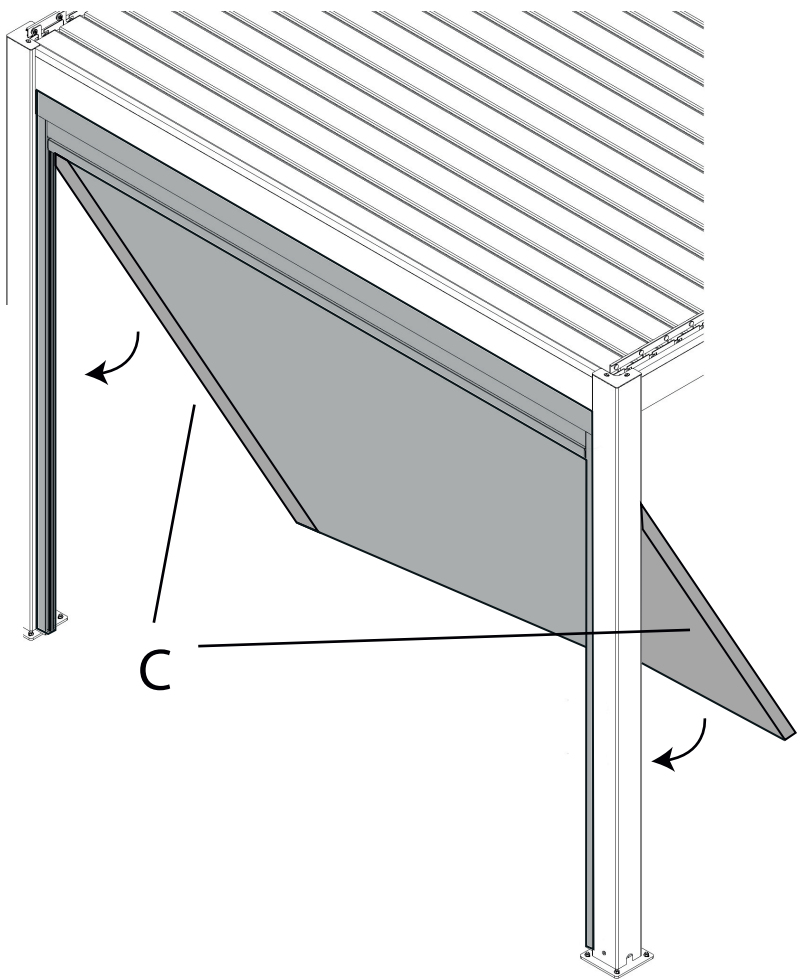

ETAPE 4
STEP 4
PASO 4

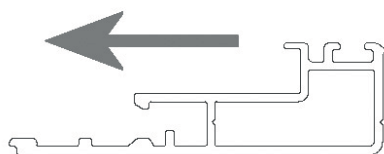
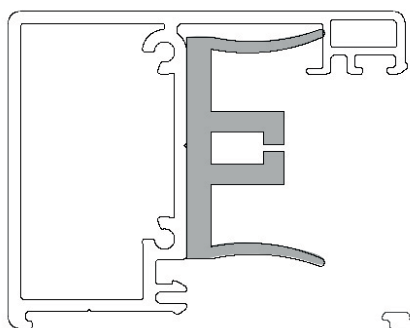
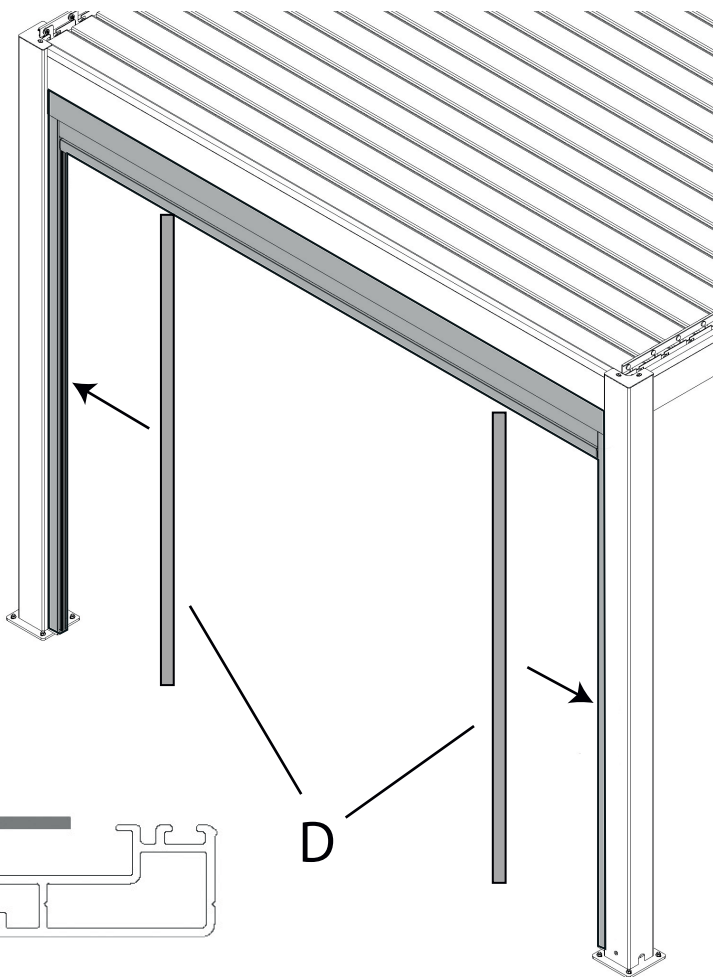

FR GARANTIE :

Votre pergola est garantie 2 ans, sauf pour les pièces d'usure telles que le système de manoeuvre et les joints des lames.

Votre garantie couvre les défauts de fabrication et les vices cachés.

Pour en bénéficier votre pergola doit :

- Etre posée conformément à la notice
- Etre entretenue régulièrement
- Etre utilisée normalement et sans avoir subi de modifications

Facteurs d'exclusion de la garantie :

- Le non-respect des conditions citées ci-dessus
- Les défauts apparents non signalés avant la mise en oeuvre du produit
- Les détériorations consécutives au montage ou à une mauvaise utilisation
- Les dommages causés par un événement extérieur.

Mise en oeuvre de la garantie :

- La garantie est limitée au remplacement des pièces défectueuses, à l'exclusion de la réparation de tout autre préjudice
- Voir avec votre point de vente :
 - Les éléments d'achats (facture, numéro commande d'origine)
 - Une description du problème
 - Des photos facilitant la compréhension

CONDITIONS D'UTILISATION:

Nos pergolas bioclimatiques sont des produits entièrement démontables et temporaires, elles n'entrent pas dans la catégorie des ouvrages permanents. Elles sont conçues pour un usage domestique et en aucun cas pour une utilisation en collectivité, elles ne sont pas soumises à la réglementation des ouvrages recevant du public. Toute utilisation d'appareil chauffant (barbecue, plancha, chauffage d'extérieur) sous ou à proximité de la pergola est interdite. En cas de vent ou de chute de neige, il est recommandé de laisser les lames ouvertes. L'épaisseur de la neige ne doit jamais excéder une épaisseur de 10cm, déblayer si nécessaire. En cas de phénomène météorologique exceptionnel ou de vent violent (plus de 90km/h), la pergola doit être démontée et rangée à l'abri.

ENTRETIEN :

Pour conserver son aspect d'origine nettoyer régulièrement à l'aide d'un chiffon humide, du savon et de l'eau tiède. Ne pas utiliser de détergents agressifs ou abrasifs. Il est normal de constater une légère alteration de la couleur avec le temps et l'usage.

MAINTENANCE :

Vérifier le serrage des vis une fois par an. S'assurer régulièrement que rien n'obstrue l'évacuation de l'eau dans les gouttières. Ne pas actionner les lames en cas de gel ou de neige. La pergola n'assure pas une étanchéité parfaite, en cas de fortes précipitations, il est possible que de l'eau traverse le toit de la pergola.

EN GUARANTEE :

Your pergola is guaranteed for 2 years, except for parts subject to wear and tear such as the operating system and the slat seals.

Your guarantee covers manufacturing defects and hidden faults.

To benefit from this guarantee your pergola must :

- Be installed in accordance with the instructions
- Be regularly maintained
- Be used normally and not have been modified

Factors excluding the guarantee :

- Failure to comply with the above conditions
- Apparent defects not reported before the product is used
- Damage caused by assembly or misuse
- Damage caused by an external event.

Implementation of the guarantee :

- The warranty is limited to the replacement of defective parts, to the exclusion of compensation for any other damage
- See your point of sale:
 - Purchase details (invoice, original order number)
 - A description of the problem
 - Photos to help you understand the problem

CONDITIONS OF USE:

Our bioclimatic pergolas are entirely removable and temporary products, they do not fall into the category of permanent structures. They are designed for domestic use and in no case for use in a community, they are not subject to the regulations for structures receiving the public. Any use of heating equipment (barbecue, plancha, outdoor heating) under or near the pergola is prohibited. In the event of wind or snowfall, it is recommended that the slats are left open. The snow should never be more than 10cm deep and should be cleared away if necessary. In the event of exceptional weather conditions or strong winds (over 90km/h), the pergola must be dismantled and stored under cover.

CLEANING :

To maintain its original appearance clean regularly with a damp cloth, soap and warm water. Do not use aggressive or abrasive detergents. It is normal to notice a slight alteration of the colour with time and use.

MAINTENANCE :

Check the tightness of the screws once a year. Regularly check that there are no obstructions in the gutters. Do not operate the slats in case of frost or snow.

ES GUARANTEE :

Su pérgola está garantizada durante 2 años, excepto las piezas sujetas a desgaste, como el sistema de funcionamiento y las juntas de las lamas.

Su garantía cubre los defectos de fabricación y los vicios ocultos.

Para beneficiarse de esta garantía, su pérgola debe :

- Ser instalado de acuerdo con las instrucciones
- Ser mantenido regularmente
- Ser utilizado normalmente y sin haber sufrido ninguna modificación

Factores que excluyen la garantía :

- Incumplimiento de las condiciones anteriores
- Defectos aparentes no comunicados antes de la utilización del producto
- Daños causados por el montaje o el mal uso
- Daños causados por un evento externo.

Aplicación de la garantía :

- La garantía se limita a la sustitución de las piezas defectuosas, con exclusión de la indemnización por cualquier otro daño
- Vea su punto de venta:
 - Detalles de la compra (factura, número de pedido original)
 - Una descripción del problema
 - Fotos para ayudarle a entender el problema

CONDICIONES DE USO:

Nuestras pérgolas bioclimáticas son productos totalmente desmontables y temporales, no entran en la categoría de estructuras permanentes. Están diseñadas para uso doméstico y en ningún caso para uso en una comunidad, no están sujetas a la normativa para estructuras que reciben al público. Se prohíbe el uso de equipos de calefacción (barbacoa, plancha, calefacción exterior) debajo o cerca de la pérgola. En caso de viento o nevadas, se recomienda dejar las lamas abiertas. La nieve nunca debe tener más de 10 cm de profundidad y debe retirarse si es necesario. En caso de condiciones meteorológicas excepcionales o de vientos fuertes (más de 90 km/h), la pérgola debe desmontarse y guardarse a cubierto.

LIMPIEZA :

Para mantener su aspecto original limpie regularmente con un paño húmedo, jabón y agua tibia. No utilice detergents agresivos o abrasivos. Es normal notar una ligera alteración del color con el tiempo y el uso.

MANTENIMIENTO :

Compruebe el apriete de los tornillos una vez al año. Compruebe regularmente que no hay obstrucciones en los canalones. No accione las lamas en caso de helada o nieve.