

Laneri[®]

sanitary ware

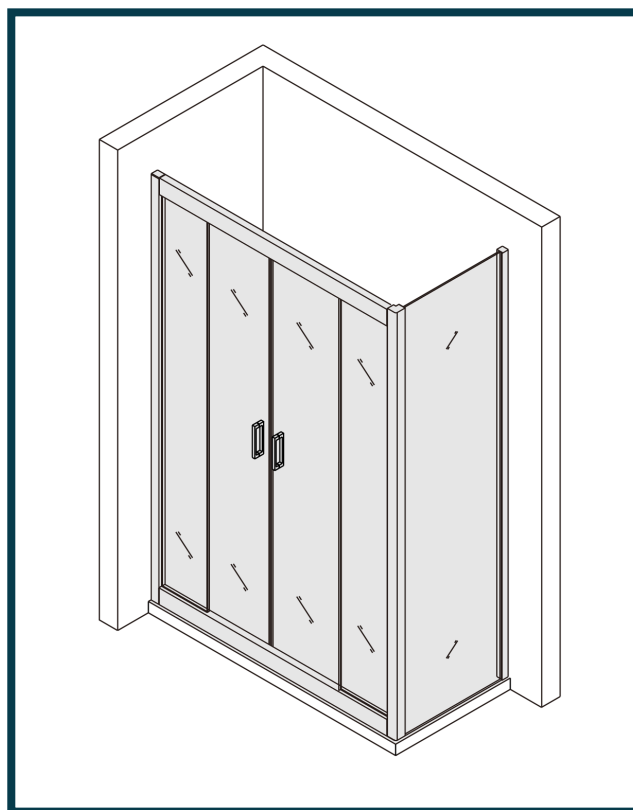
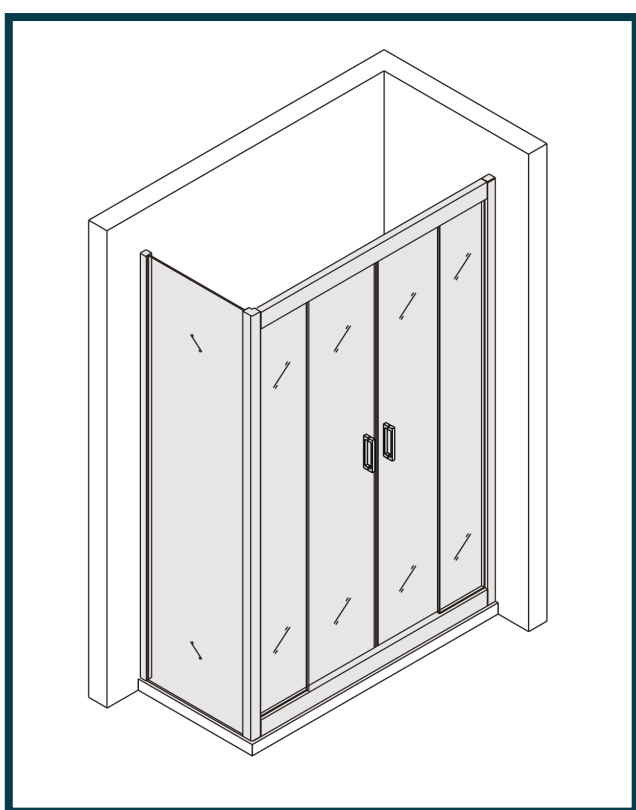

 YouTube LANERI SRL

Manhattan 2.0



ITALIANO PAG. 3



FRANÇAIS PAG. 13



DEUTSCH PAG. 23

Laneri

sanitary ware

c/da Gentilomo snc
94100 Enna Italy
www.laneribagni.it

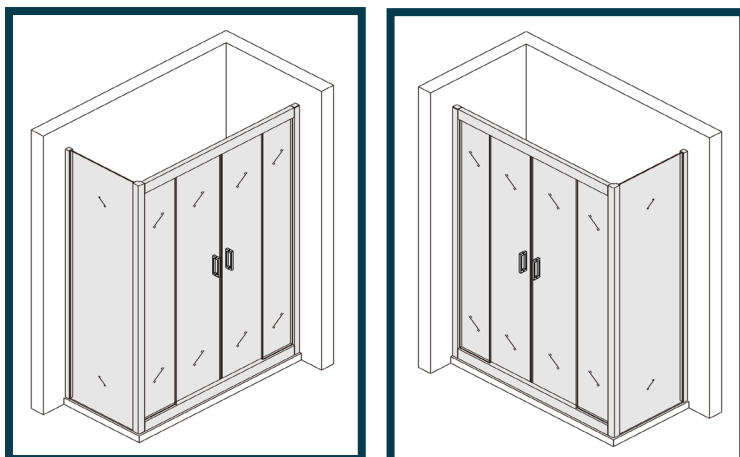

Manhattan 2.0

DESCRIZIONE

Box doccia scorrevole con ingresso centrale e parete fissa laterale abbinata. Realizzato in vetro temperato 6mm h 190. Installazione reversibile. Possibilità di sgancio rapido dei carrelli inferiori. Regolaggio manuale dei profili a muro di 2,5 cm per lato. Telaio in alluminio cromato, Vetro con trattamento anticalcare segnalato da apposite etichette verdi.

ELABORATO TECNICO

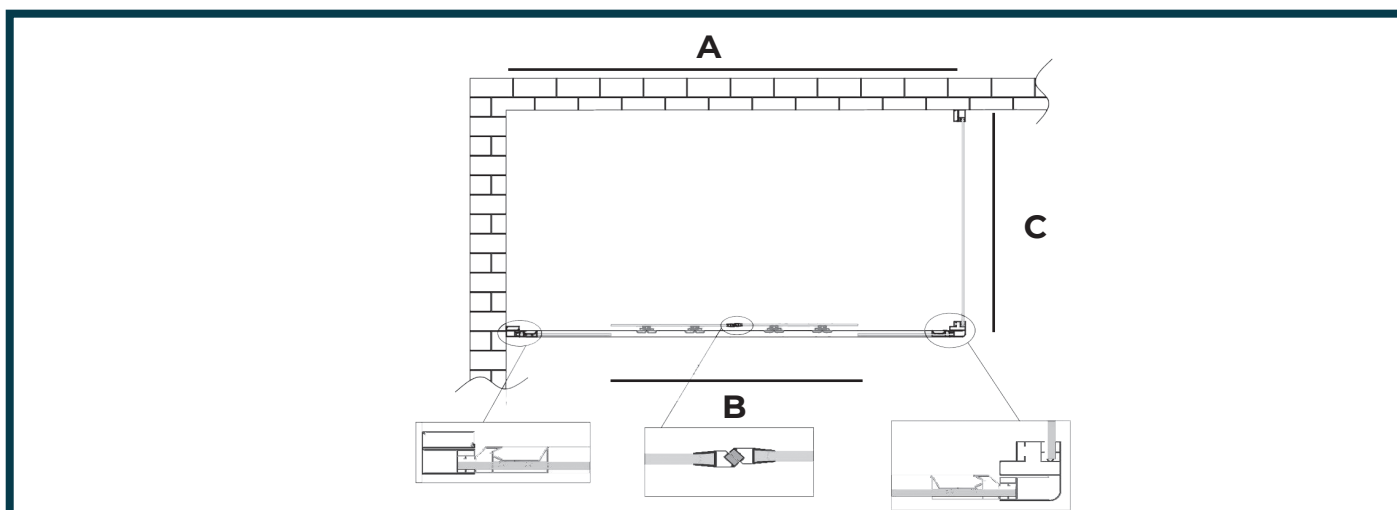

DETTAGLIO PROFILI

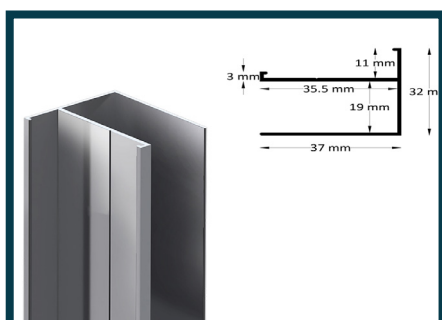

Profilo muro fisso

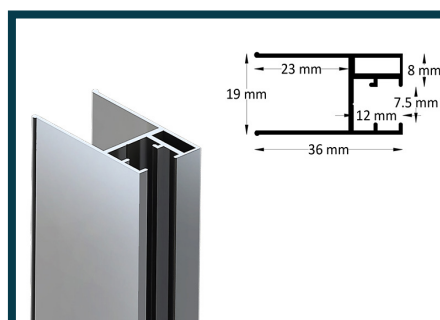

Profilo vetro fisso

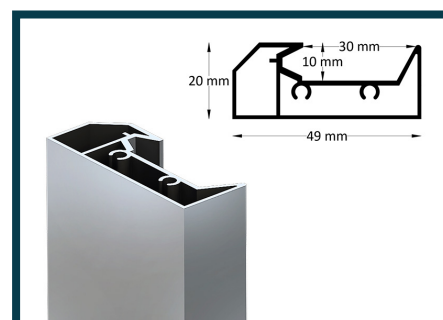

Profilo binario ruote

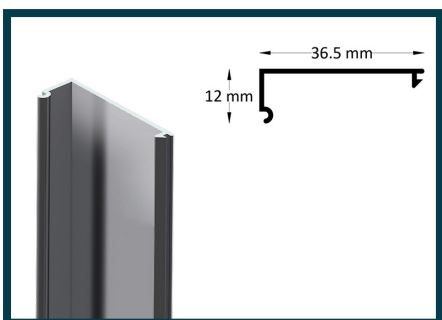

Profilo cover

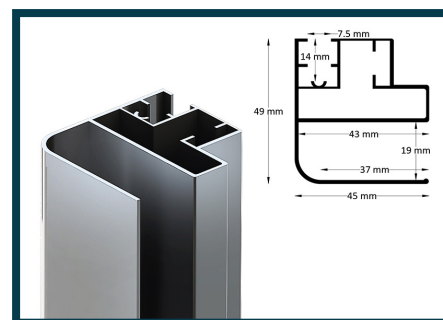

Profilo angolare

Laneri

sanitary ware

c/da Gentilomo snc
94100 Enna Italy
www.laneribagni.it

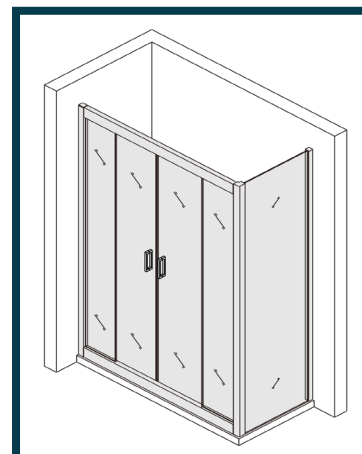
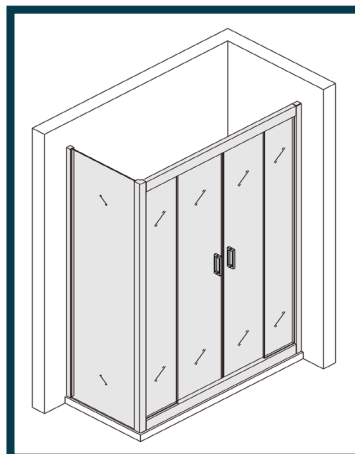

Manhattan 2.0

MISURE PORTA	MISURE A	MISURE B
130 (lunghezza binario 120)	1280 - 1330	560
135 (lunghezza binario 125)	1330 - 1380	535
140 (lunghezza binario 130)	1380 - 1430	610
145 (lunghezza binario 135)	1430 - 1480	585
150 (lunghezza binario 140)	1480 - 1530	660
155 (lunghezza binario 145)	1530 - 1580	535
160 (lunghezza binario 150)	1580 - 1630	610
165 (lunghezza binario 155)	1630 - 1680	685
170 (lunghezza binario 160)	1680 - 1730	760
175 (lunghezza binario 165)	1730 - 1780	635
180 (lunghezza binario 170)	1780 - 1830	710
185 (lunghezza binario 175)	1830 - 1880	785
190 (lunghezza binario 180)	1880 - 1930	860
195 (lunghezza binario 185)	1930 - 1980	735
200 (lunghezza binario 190)	1980 - 2030	810
205 (lunghezza binario 195)	2030 - 2080	885
210 (lunghezza binario 200)	2080 - 2130	960

MISURE PARETE FISSA	MISURE C
65	625 - 650
67,5	650 - 675
70	675 - 700
75	725 - 750
80	775 - 800
90	875 - 900
100	975 - 1000

MANHATTAN 2.0

UTENSILI NECESSARI



Matita

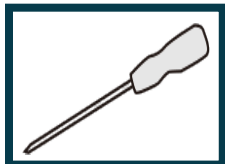

Cacciavite

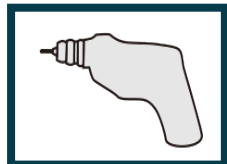

Trapano

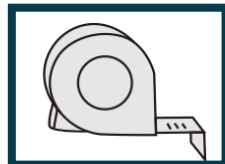

Metro a nastro

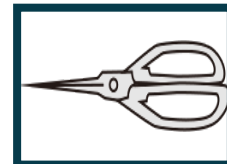

Forbice

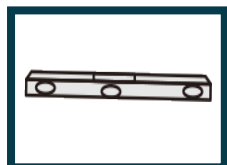

Livello

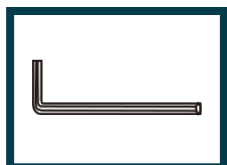

Chiave esagonale
(in dotazione)

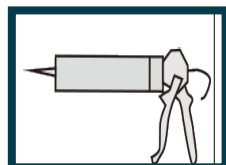

Silicone



Martello di
gomma

CONTENUTO DELLA CONFEZIONE

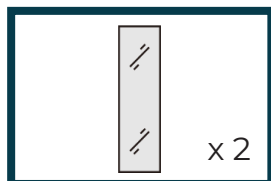

Vetro fisso x 2

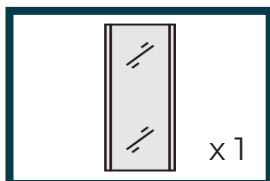

Anta fissa laterale
h 1.90 x 1

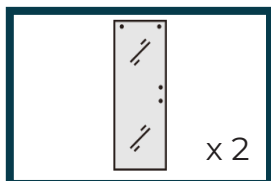

Vetro scorrevole x 2

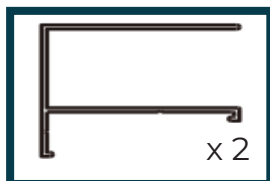

Profilo muro
h 1.90 x 2

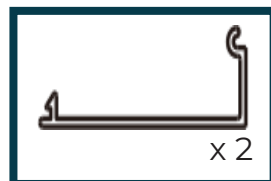

Cover profilo muro
h 1.90 x 2

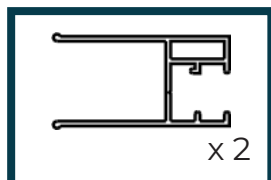

Profilo vetro fisso x 2



Montante
scorrevole x 2

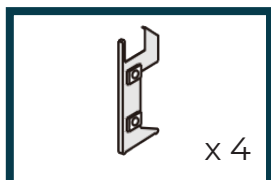

Connettore lato
fisso con asola x 4



Vite 4 x 10
Per fine corsa x 8

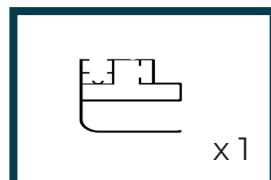

Profilo angolare
h 1.90 x 1



Ruote inferiori
sganciabili x 4



Ruote superiori x 4

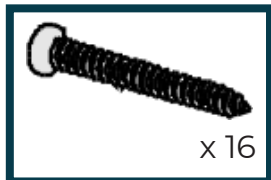

Vite 4 x 30 x 16

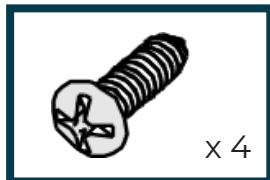

Vite 4 x 16 x 4



Vite 4 x 12 x 8

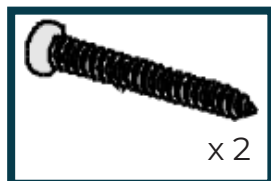

Vite 4 x 20 x 2

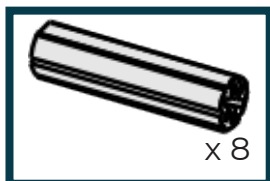

Tassello x 8

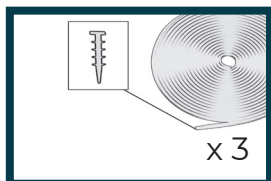

Guarnizione a
rolo ferma vetro x 3

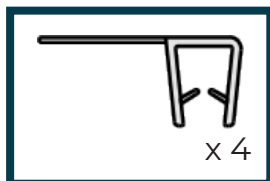

Guarnizione
aletta paraschizzi x 4

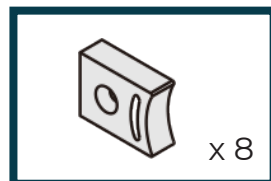

Fine corsa x 8

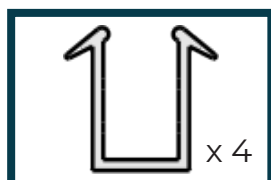

Guarnizione
protezione vetri x 4

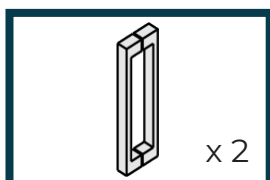

Maniglie x 2

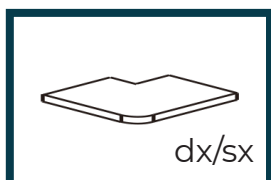

Cover profilo
angolare dx/sx

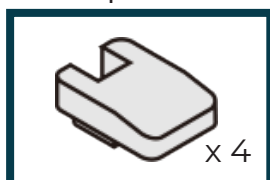

Cover x 4



Guarnizione
calamita x 2

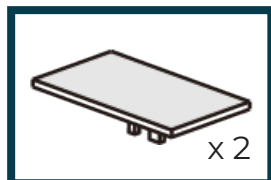

Cover superiore
ferma vetro fisso x 2

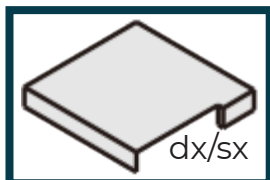

Cover superiore
profilo muro dx/sx

MONTAGGIO

1° PASSAGGIO

1. Verificare la messa in bolla del piatto doccia con il livello.
2. Poggiare il profilo a muro ed utilizzare il livello per la messa a piombo.
3. Tracciare i fori a muro con la matita.
4. Praticare i fori a muro con il trapano.
5. Inserire il tassello a muro e avvitare le viti per fissare il profilo.

IMPORTANTE

è buona norma non montare i profili a ridosso del bordo esterno del piatto doccia, lasciare sempre circa 1 cm per un risultato estetico ottimale

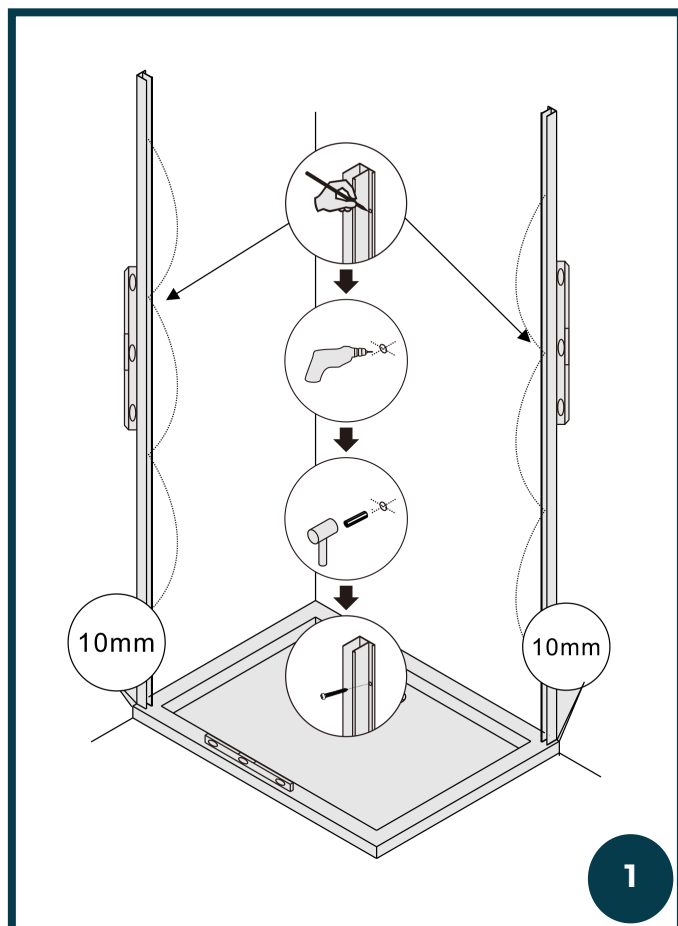

2° PASSAGGIO

1. Usare la vite 4x30 per collegare il binario in alluminio inferiore con il profilo verticale. In questo modo costruiamo il telaio della porta (scheletro).
USARE I CONNETTORI CON ASOLA (X2) PER COLLEGARE TELAIO ORIZZONTALE CON TELAIO VERTICALE

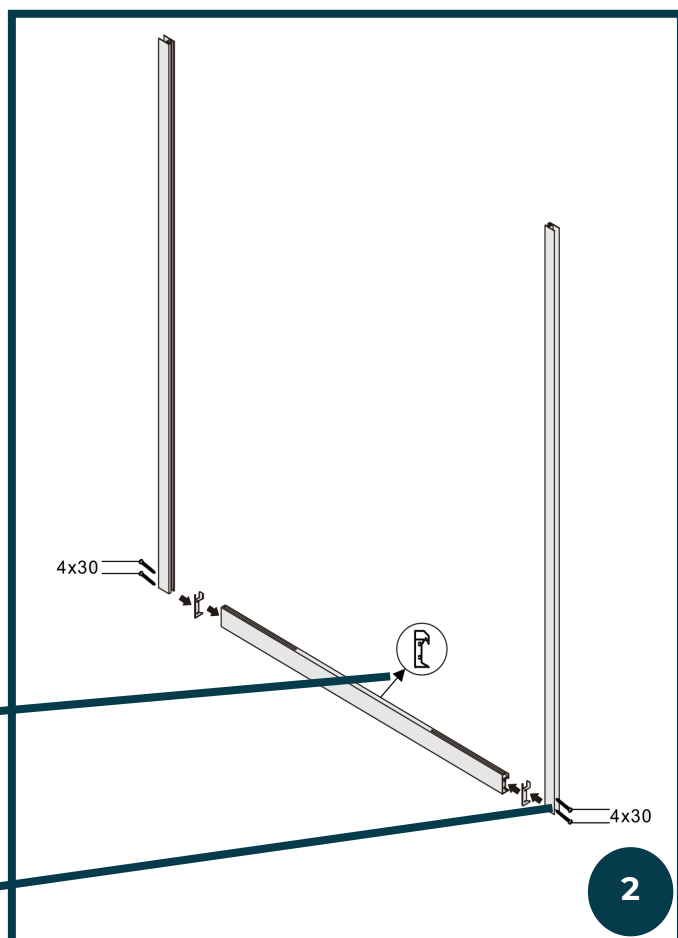
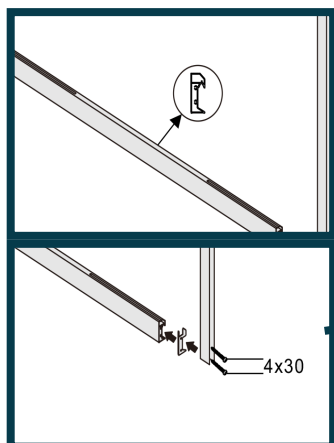

3° PASSAGGIO

1. Mettere le parti in plastica nel binario di alluminio come in figura A. (cover)
2. Posizionare la guarnizione nel profilo inferiore. Come in figura A. (Guarnizione protezione vetri)
3. Inserire i vetri fissi come in figura B.

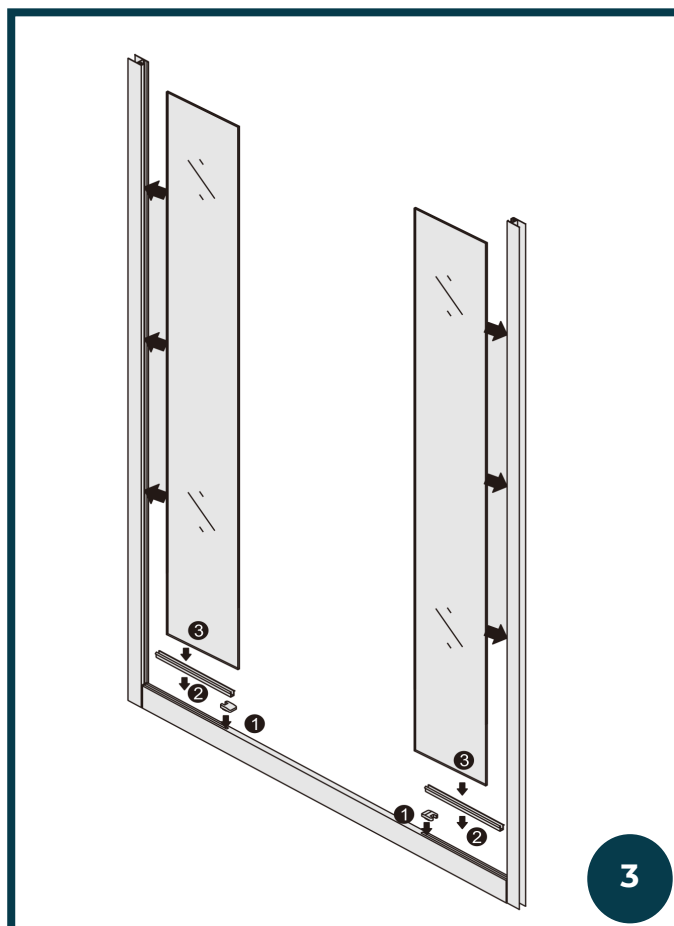
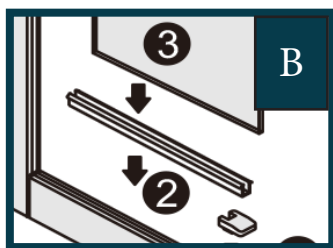
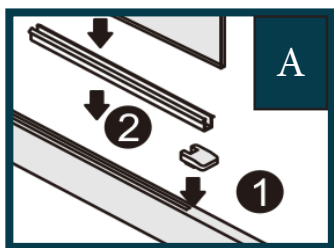

3

4° PASSAGGIO

1. Ripetere il passaggio (2 e 3) precedente per la parte alta del telaio

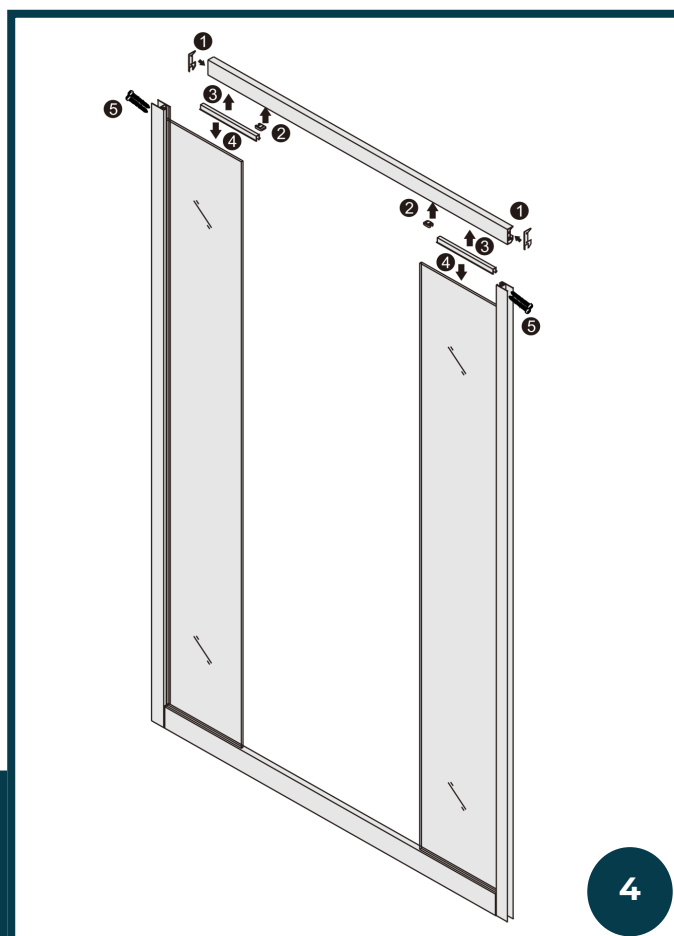
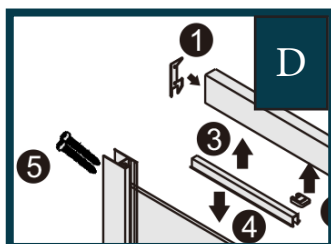
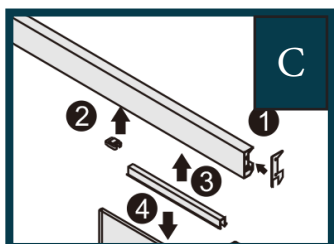

4

5° PASSAGGIO

1. Inserire il telaio, precedentemente assemblato, dentro il profilo a muro.
2. Regolare l'estensione del telaio agendo sul telescopico (1 profilo entra dentro l'altro)

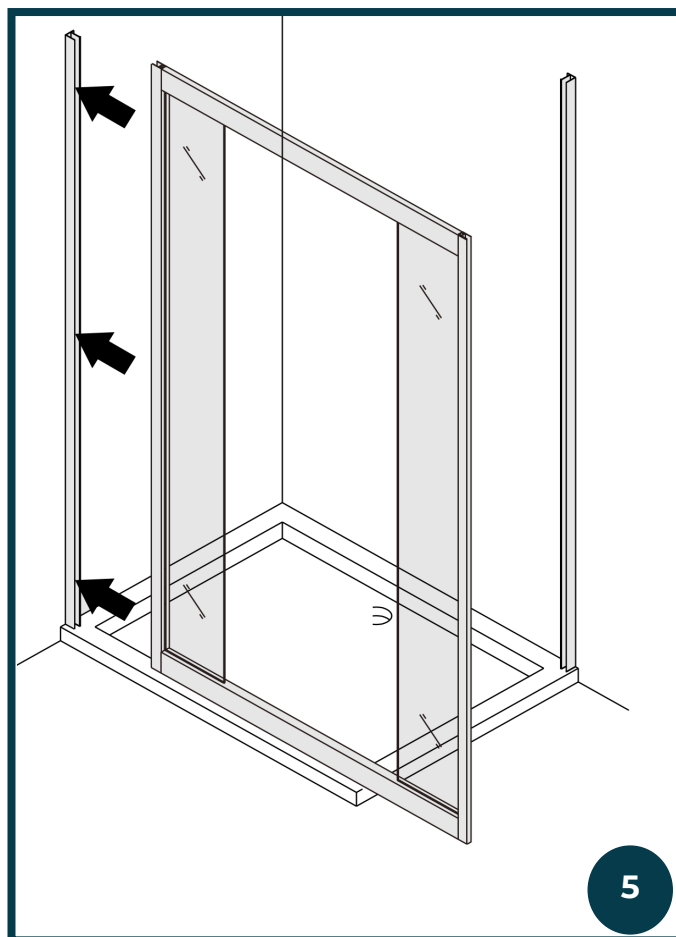

6° PASSAGGIO

1. Applicare il silicone nell'insenatura del profilo ad angolo.
2. Inserire il vetro fisso all'interno del profilo ad angolo e mentre fresco dunque completare il passaggio successivo (7)

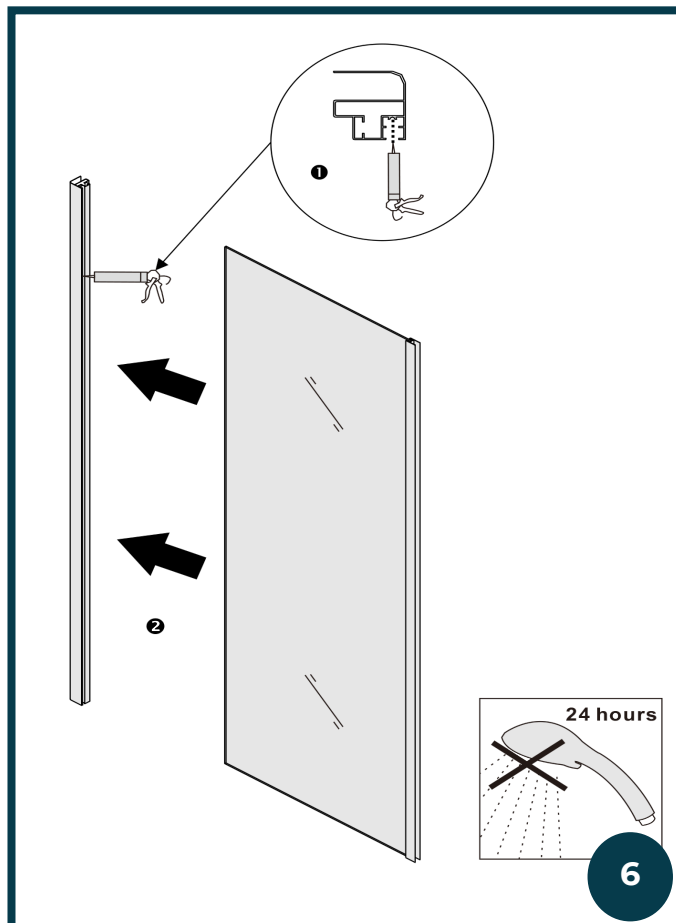

7° PASSAGGIO

1. Installare la guarnizione ferma vetro tra il vetro e il profilo in alluminio ad angolo avendo cura di inserirla dal basso verso l'alto .
2. la guarnizione da usare è quella arrotolata nella bustina , va inserita a pressione tra vetro e telaio dal basso verso l'alto. (se lunga accorciare)

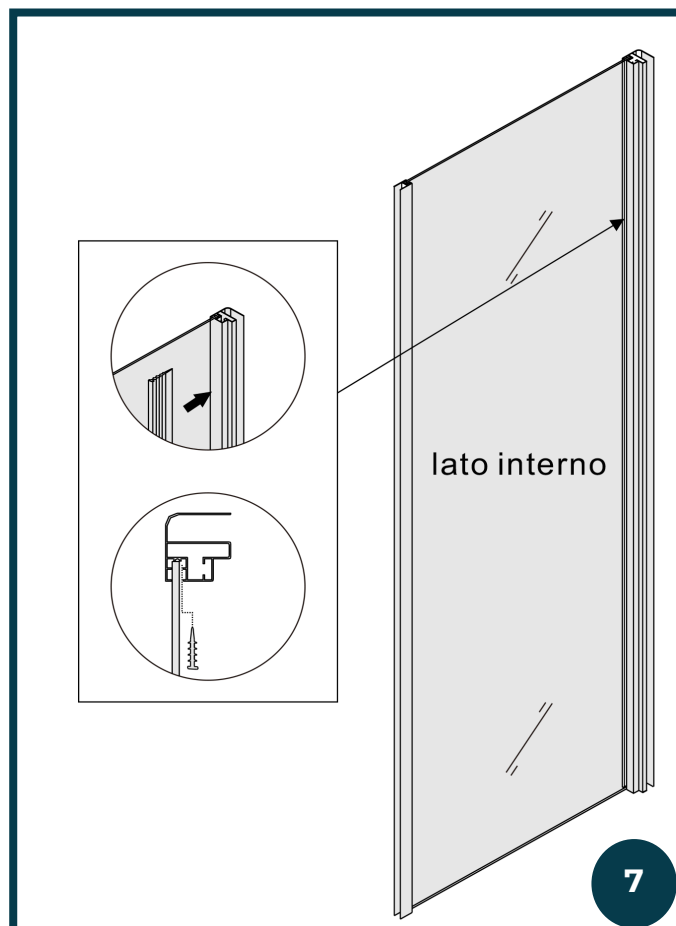

8° PASSAGGIO

1. Inserire la parete fissa tra il profilo a muro e il profilo in alluminio ad angolo della porta.

NOTA BENE:

sotto la lastra fissa non ci va nulla ,
va poggiata e siliconata dall'esterno.

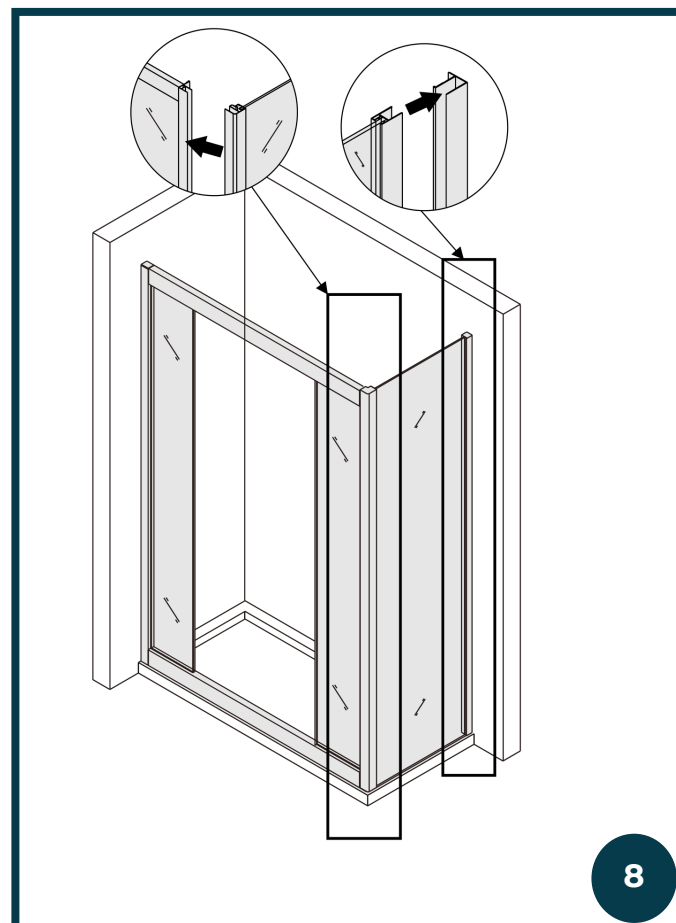

9° PASSAGGIO

1. Installare le rotelle di scorrimento inferiori (con pulsante per sgancio rapido) e superiori.

Nota: le **ruote superiori** sono regolabili, se, dopo aver montato il box doccia, le ante non dovessero avere uno scorrimento fluido è possibile regolarle tramite la vite inferiore sul cuscinetto superiore.

Le ruote di scorrimento inferiori sono sganciabili per facilitare le operazioni di pulizia e manutenzione ordinaria.

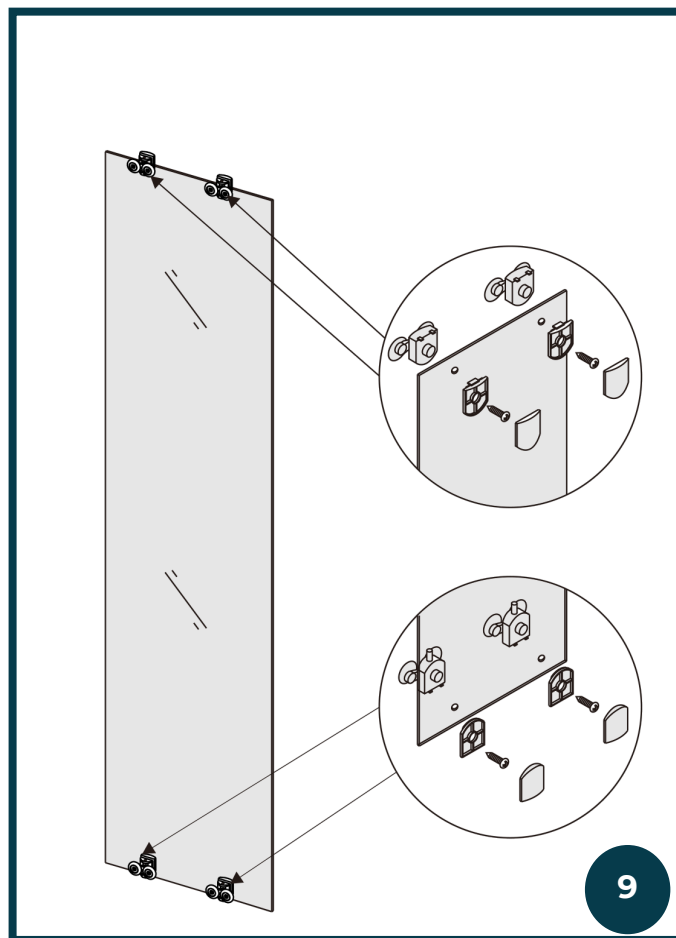

10° PASSAGGIO

1. Agganciare le ante al binario di scorrimento. Accertarsi che la porta sia in asse, vedi passaggio precedente per regolarle.

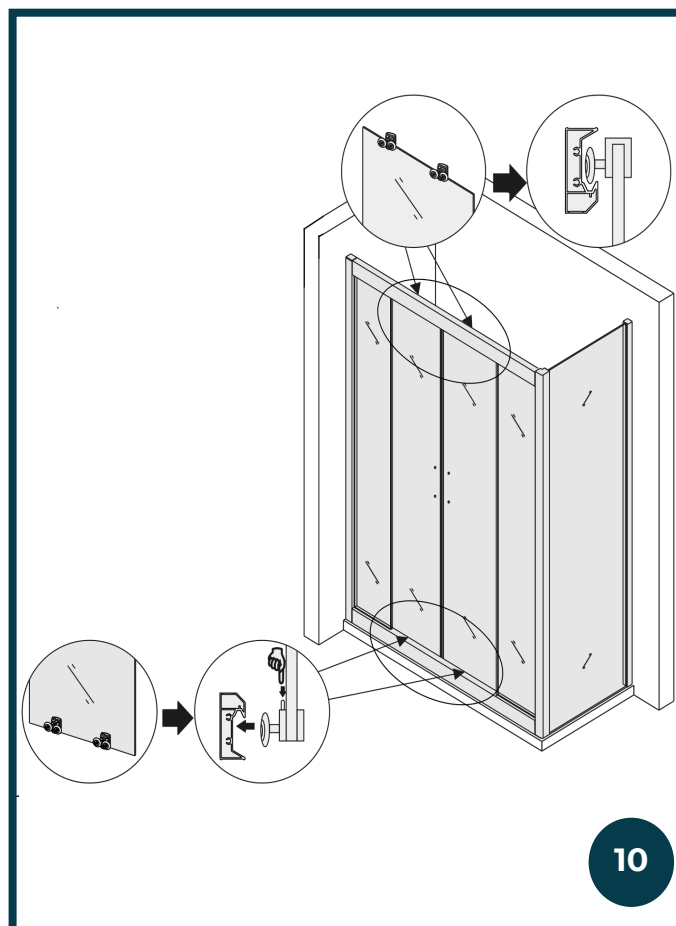

11° PASSAGGIO

1. Installare le guarnizioni magnetiche di chiusura sul vetro.
2. Inserire la guarnizione piatta tra il vetro fisso e il profilo in alluminio (lato interno).
La trovi arrotolata in una bustina!!
3. Verificare la messa a piombo, quindi praticare dei fori e applicare le viti dal lato interno per bloccare la parete al profilo a muro, poi ricoprire il tutto con il profilo decorativo in alluminio.
(Cover alta 190 cm che va sciolare il profilo a muro e nasconde i fissaggi)

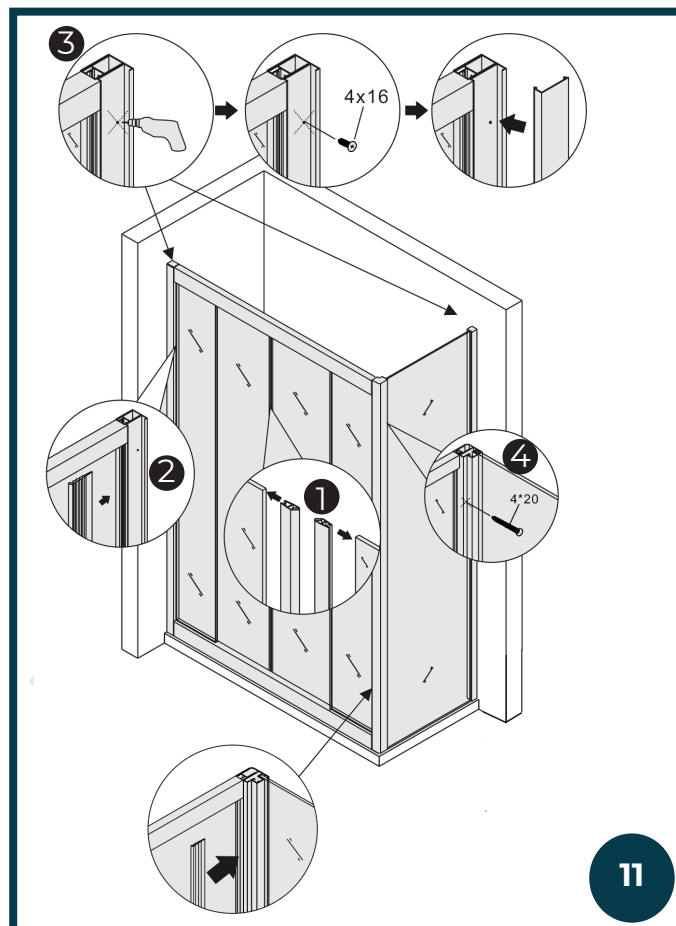

12° PASSAGGIO

1. Installare il fine corsa sul binario sopra e sotto. Usare le viti più piccole che vi sono in dotazione, altrimenti si rischia di bucare il lato a vista del binario di scorrimento.
2. Installare la maniglia.
3. Installare la guarnizione di tenuta tra vetro fisso e porta scorrevole.

ATTENZIONE

In dotazione c'è una guarnizione più alta ed una più bassa, quella più bassa va sul vetro fisso, quella più alta nel vetro scorrevole.

4. Installare i tappini di copertura nella parte superiore del profilo in alluminio e siliconare la parte esterna del box doccia lungo tutto il perimetro come mostrato in figura.

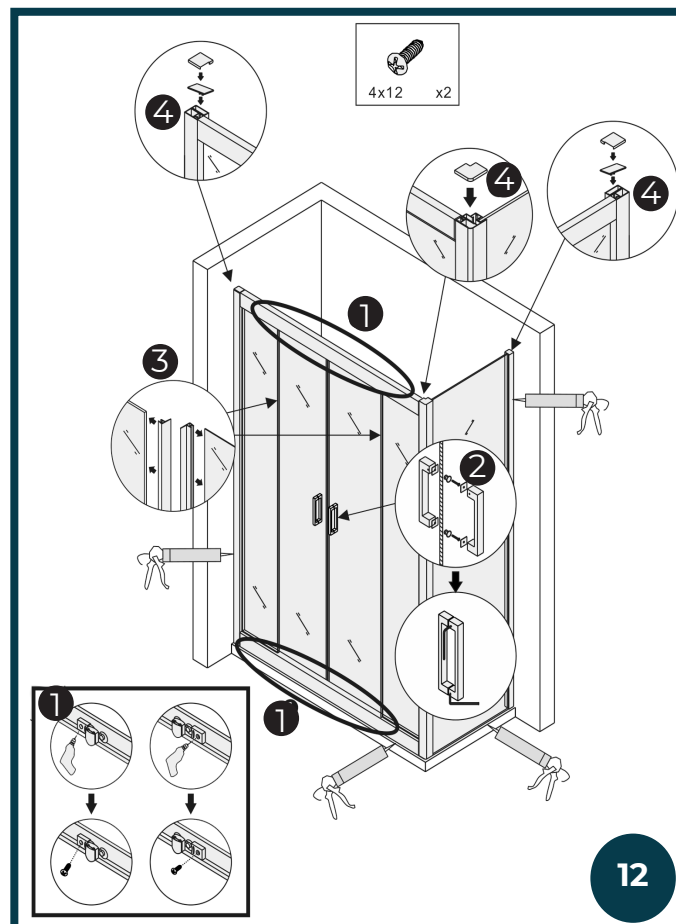

Laneri®

sanitary ware

c/da Gentilomo snc
94100 Enna Italy
www.laneribagni.it

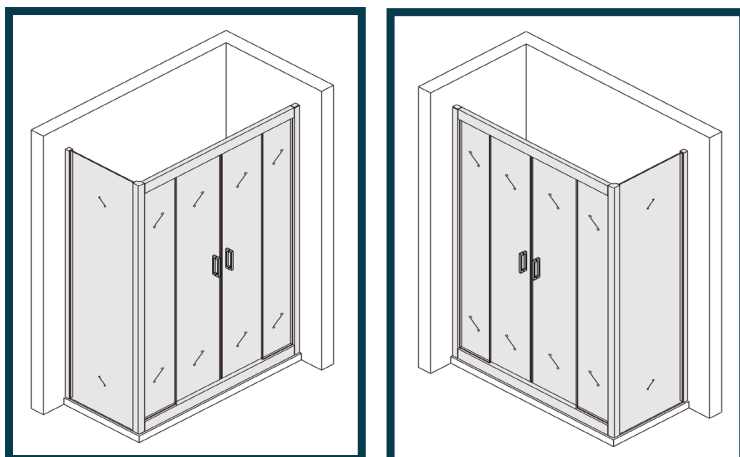

Manhattan 2.0

DESCRIPTION

Douche coulissante avec entrée centrale et paroi fixe laterale. H.190 en verre trempé de 6 mm. Installation réversible. Roulements inférieur détachables. Réglage jusqu'à 2.5 cm grace aux profilés murales. Châssis en aluminium chromé anti-calcaire, verre anti-calcaire signalé avec etiquette verte.

SPÉCIFICATION TECHNIQUE

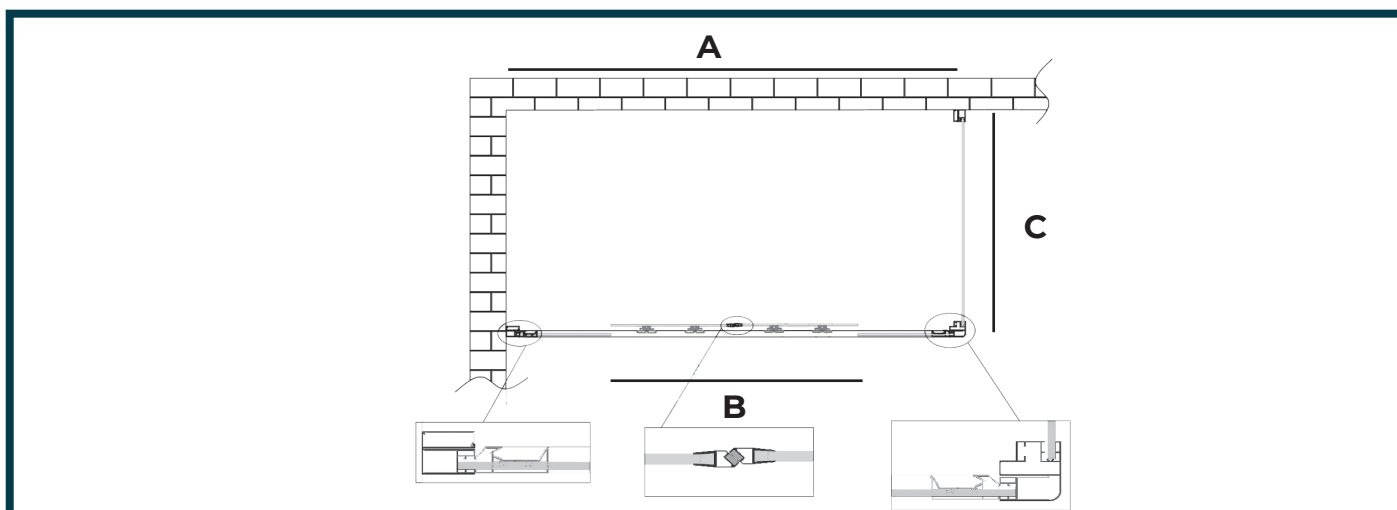

PROFILÉS EN DÉTAIL

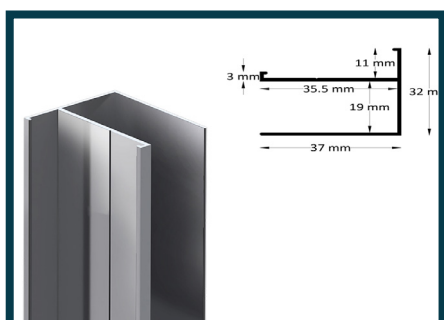

Profilé mural fixe

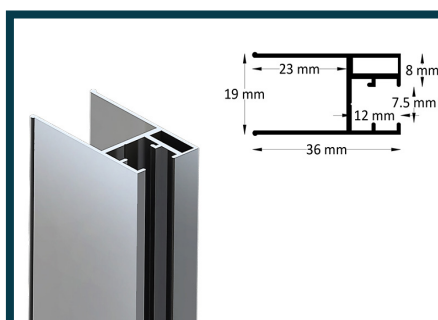

Profilé pour le verre fixe

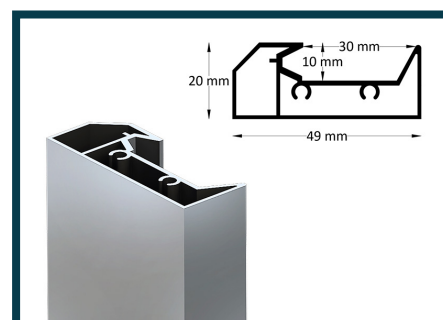

Joint pour rail des roulements

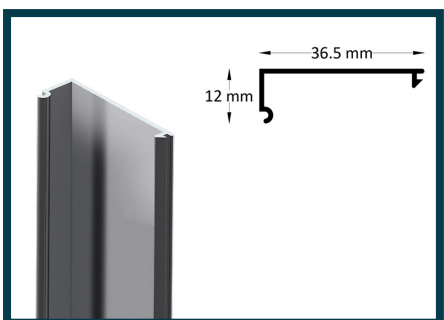

Profilé de couverture

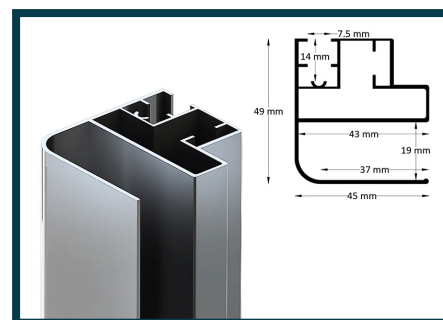

Profilé angulaire

Laneri

sanitary ware

c/da Gentilomo snc
94100 Enna Italy
www.laneribagni.it

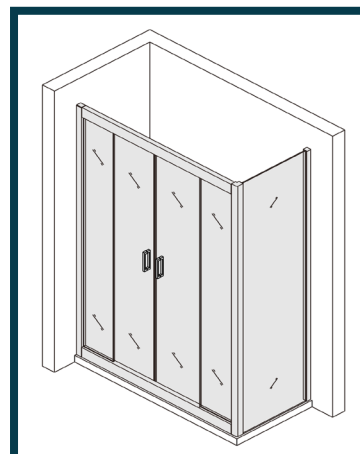
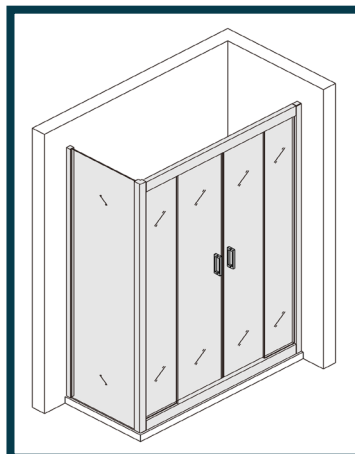

Manhattan 2.0

MESURES DE LA PORTE	MESURES A	MESURES B
130 (Longueur du rail 120)	1280 - 1330	560
135 (Longueur du rail 125)	1330 - 1380	535
140 (Longueur du rail 130)	1380 - 1430	610
145 (Longueur du rail 135)	1430 - 1480	585
150 (Longueur du rail 140)	1480 - 1530	660
155 (Longueur du rail 145)	1530 - 1580	535
160 (Longueur du rail 150)	1580 - 1630	610
165 (Longueur du rail 155)	1630 - 1680	685
170 (Longueur du rail 160)	1680 - 1730	760
175 (Longueur du rail 165)	1730 - 1780	635
180 (Longueur du rail 170)	1780 - 1830	710
185 (Longueur du rail 175)	1830 - 1880	785
190 (Longueur du rail 180)	1880 - 1930	860
195 (Longueur du rail 185)	1930 - 1980	735
200 (Longueur du rail 190)	1980 - 2030	810
205 (Longueur du rail 195)	2030 - 2080	885
210 (Longueur du rail 200)	2080 - 2130	960

MESURES DE LA PAROI FIXE	MESURES C
65	625 - 650
67,5	650 - 675
70	675 - 700
75	725 - 750
80	775 - 800
90	875 - 900
100	975 - 1000

MANHATTAN 2.0

USTENSILES NECESSAIRES



Crayon



Tournevis



Forage



Ruban à mesurer

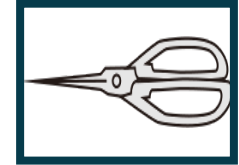

Ciseaux

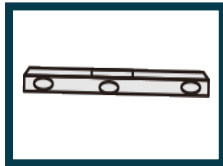

Niveau



Clé à douille
(en dotation)

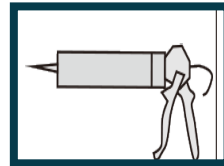

Silicone

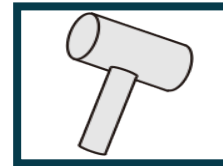

Maillet en caoutchouc

ACCESSOIRES INCLUS DANS LE COLIS

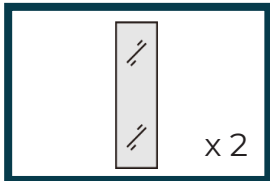

Verre fixe

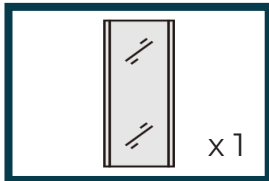

Verre de la paroi
fixe h 1.90

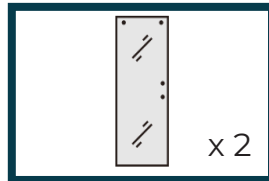

Verre coulissante

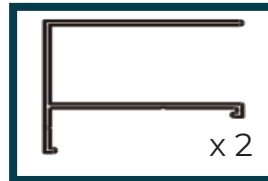

Profilé mural h 1.90

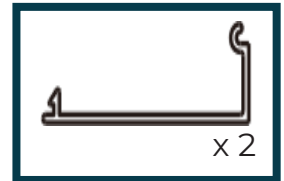

Profilé de couverture
h 1.90

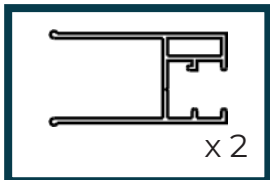

Profilé pour le verre
fixe



Rail pour le coulisement

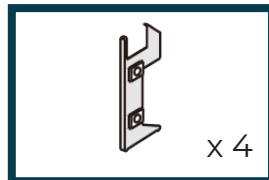

Raccord du verre
fixe avec boucle



Vis 4 x 10
Butée

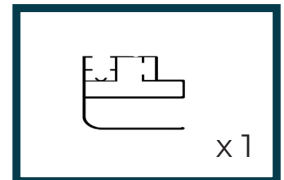

Profilé angulaire h
1.90



Roulements inférieurs
détachables



Roulements supérieurs

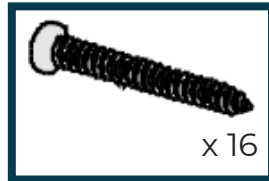

Vis 4 x 30

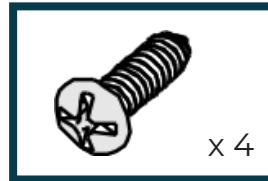

Vis 4 x 16



Vis 4 x 12

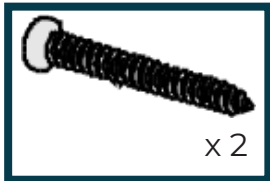

Vis 4 x 20

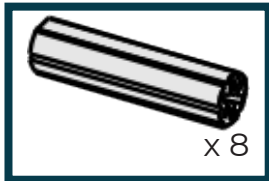

Morceaux

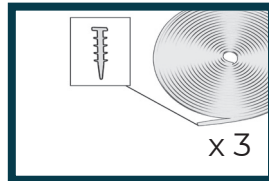

Joint enroulé pour
bloquer le verre

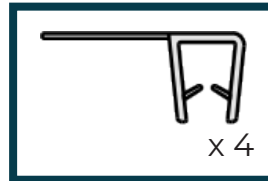

Joint d'étanchéité
avec ailette

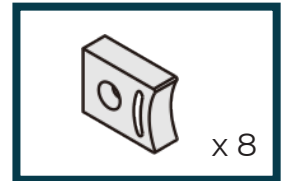

Butée

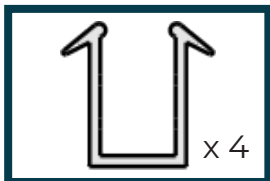

Joint de protection

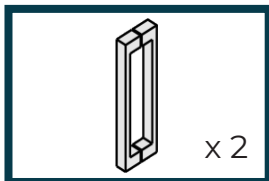

Poignée

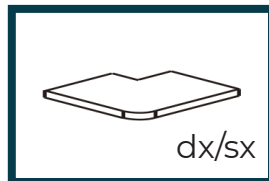

Couverture du profilé
angulaire

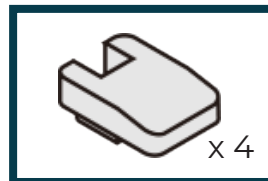

Couverture



Joint magnétique

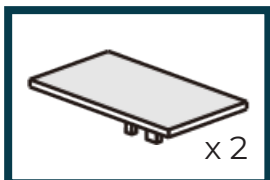

Couverture supérieur
pour bloquer le verre fixe

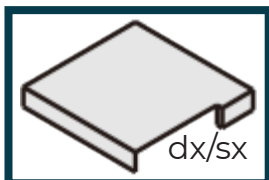

Couverture supérieur
du profilé mural

Installation

1° ÉTAPE

1. Vérifiez le nivellement du receveur de douche avec le niveau.
2. Appuyez le profilé mural et utiliser le niveau pour la mise à plombe.
3. Tracer les trous sur le mur avec le crayon.
4. Faites le trous avec le forage.
5. Placez les morceaux et vissez les vis pour le fixer sur la paroi.

IMPORTANT:

Nous recommandons de pas installer le profilé à proximité du bord extérieur du receveur de douche, mais de laisser au moins 1 cm du bord, pour une installation optimale.

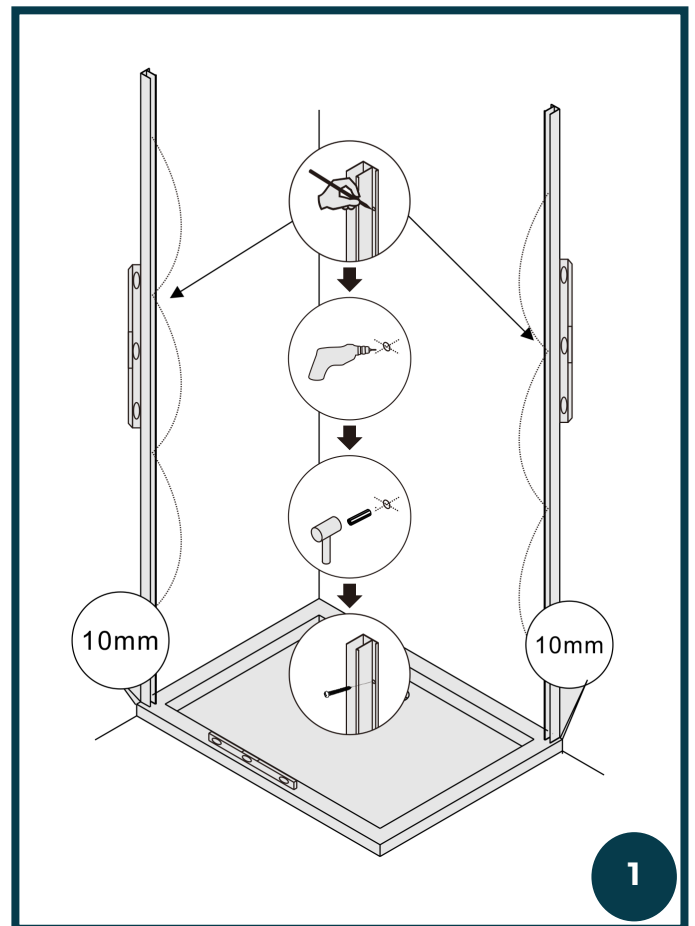

2° ÉTAPE

1. Utiliser la vis 4x30 pour connecter le rail inférieur en aluminium avec le profilé vertical. De cette manière vous construirez le châssis de la porte (squelette).

UTILISER LE CONNECTEUR AVEC LE BOUCLE (X2) POUR CONNECTER LE CHÂSSIS HORIZONTALE AVEC LE CHÂSSIS VERTICALE.

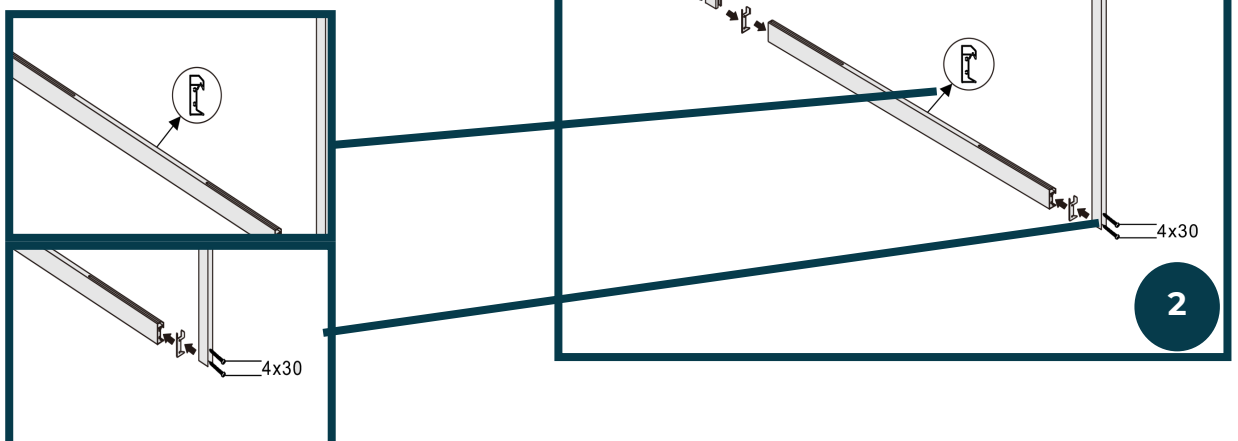

3° ÉTAPE

1. Mettre les composants en plastique dans le rail en aluminium selon l'illustration A. (couverture)
2. Placer le joint dans le profilé inférieur . Selon l'illustration A. (Joint de protection)
3. Insérer le verre fixe selon l'illustration B.

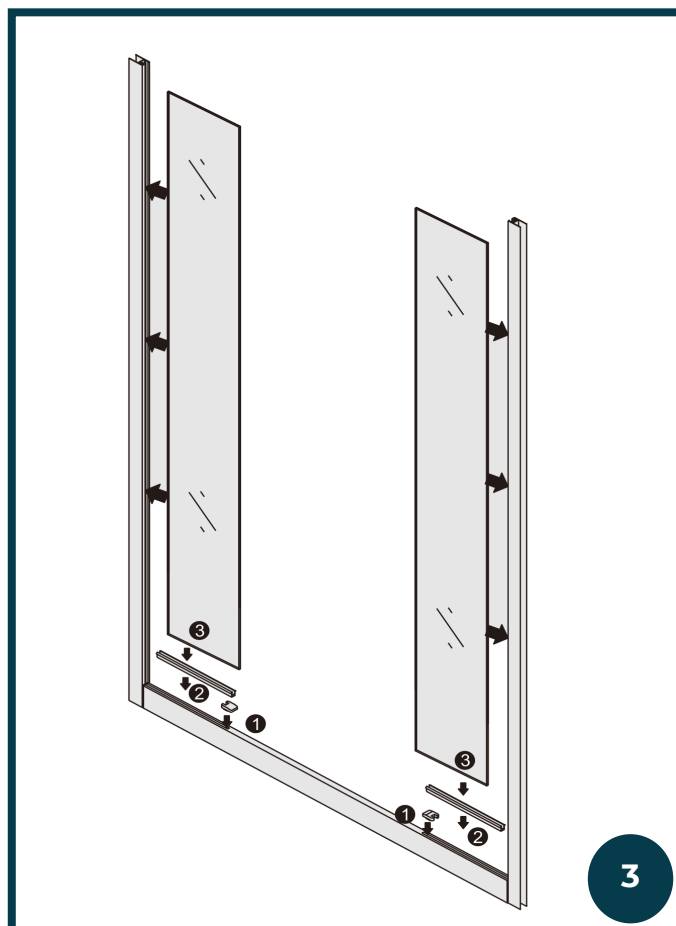
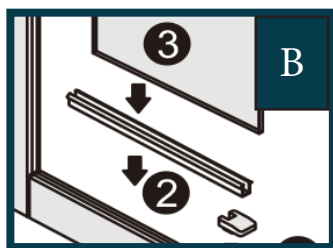
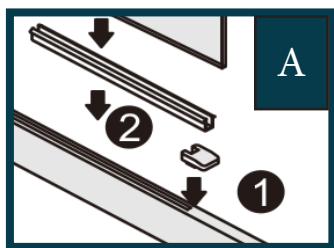

3

4° ÉTAPE

1. Répétez l'étape (2 e 3) pour l'installation de la partie supérieur du châssis.

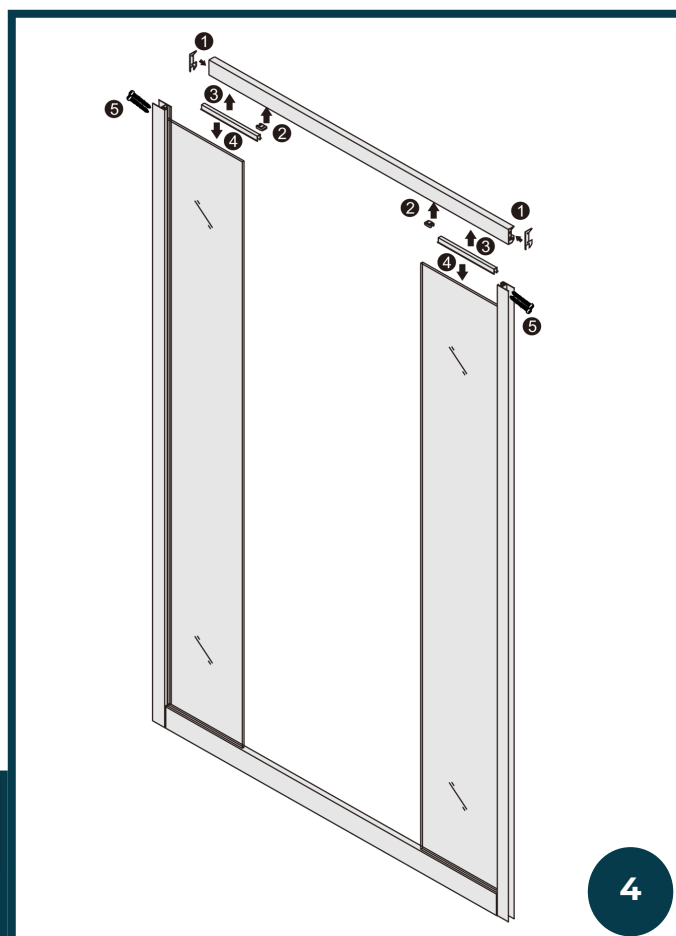
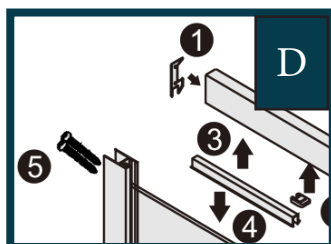
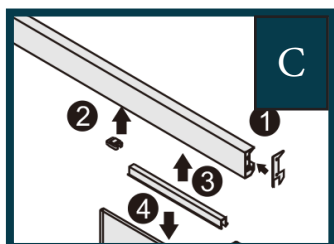

4

5° ÉTAPE

1. Insérez le châssis, précédemment assemblé avec le mur fixe, dans le profilé mural.
2. Régulez l'extension du châssis en agissant sur le télescopique (1 profilé entre dans l'autre).

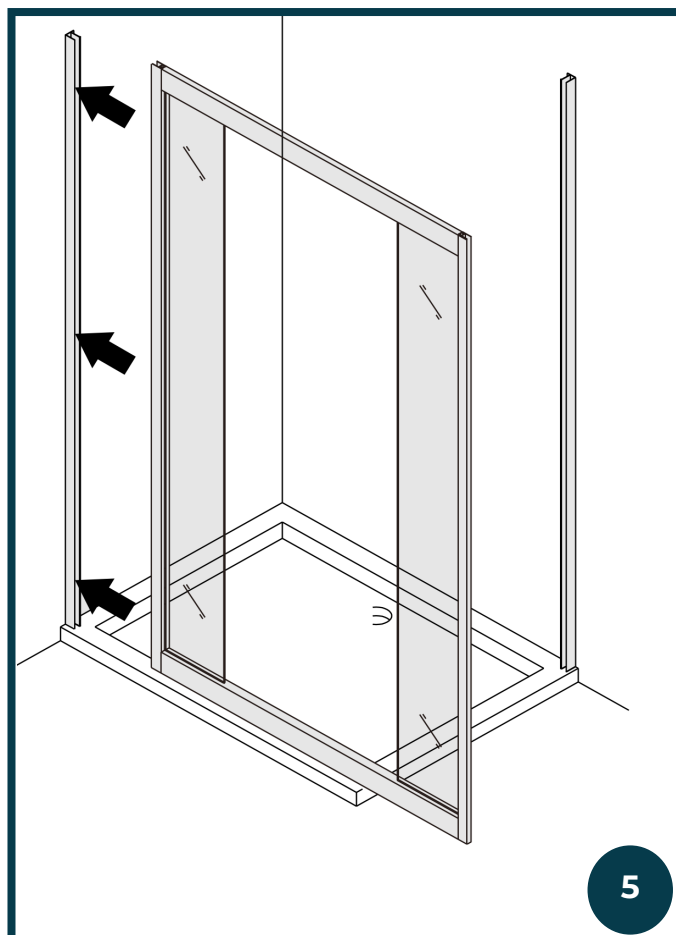

6° ÉTAPE

1. Appliquez le silicone dans la crique du profilé angulaire.
2. Insérez le verre fixe dans le profilé angulaire et pendant que le silicone est frais complétez l'étape suivante (7)

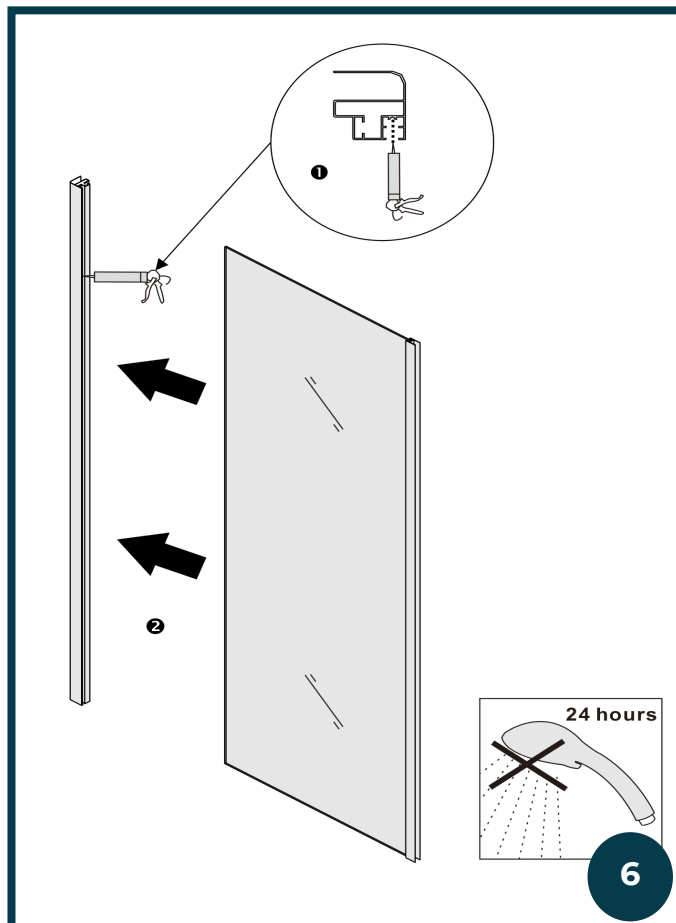

7° ÉTAPE

1. Installez les joints qui bloquent le verre entre le profilé angulaire en aluminium et le verre. Insérez le joint de bas en haut.
2. Le joint en question est enroulé dans un paquet et doit être inséré à pression entre le verre et le châssis.

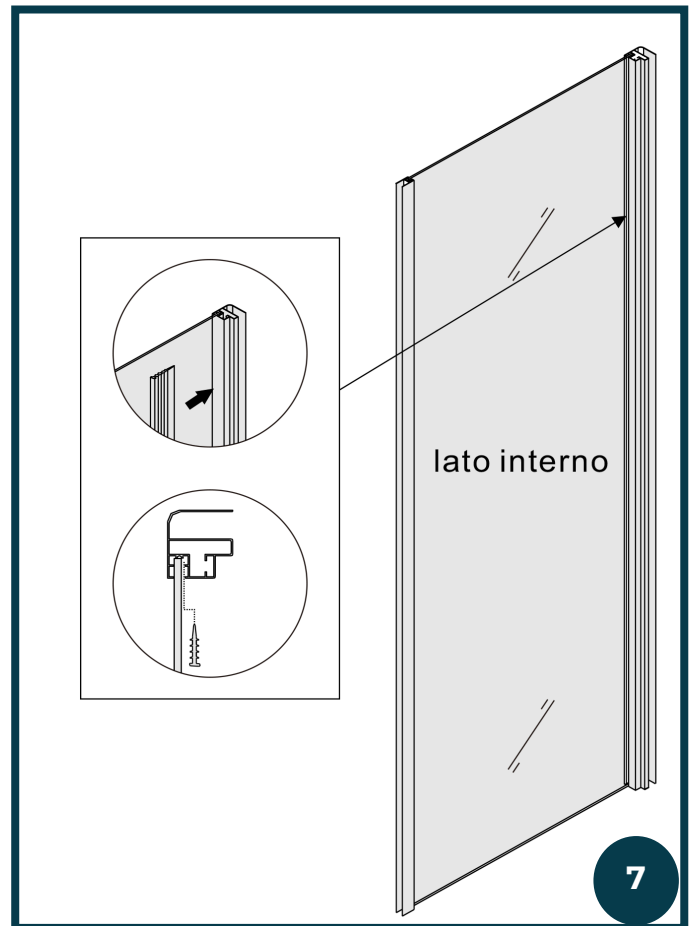

8° ÉTAPE

1. Insérez la paroi fixe entre le profilé mural et le profilé en aluminium de la porte antérieure.

NOTEZ BIEN:

Aucun composant doit être installé sous la paroi fixe latérale. Elle doit être appuyée sur le receveur. Après, mettez du silicone par l'extérieure.

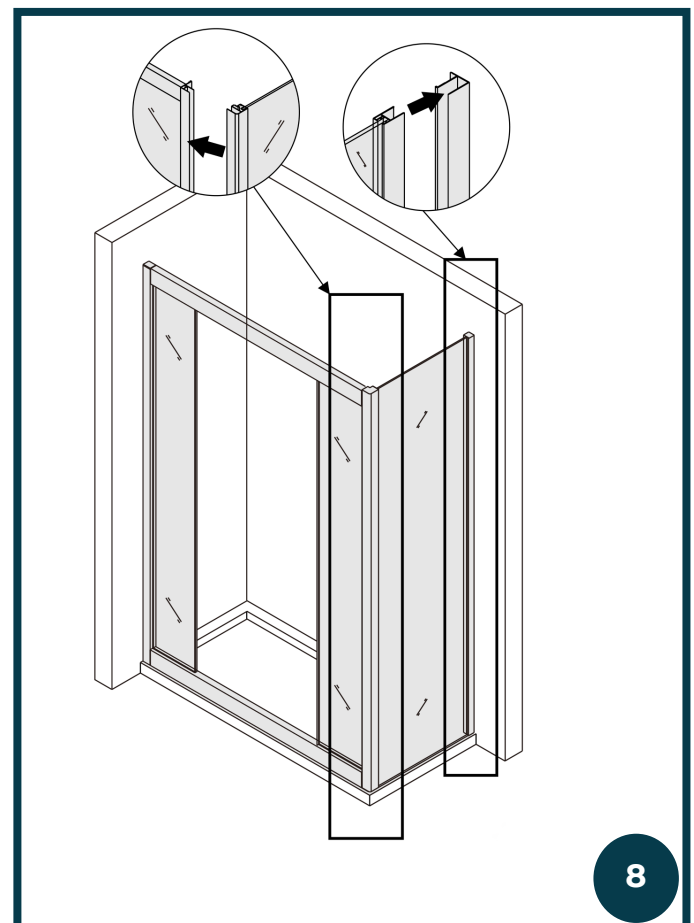

9° ÉTAPE

1. Installez les roulettes de coulissement inférieurs (avec bouton de largage) et supérieurs.

Notez : Les **roulettes supérieurs** sont réglables. Si, après le montage de la porte, le coulissement n'est pas fluide, les roulette peuvent être réglé à travers de la vis inférieur sur le roulement.

Les roulettes de coulissement inférieurs sont détachables pour favoriser le nettoyage et la l'entretien ordinaire.

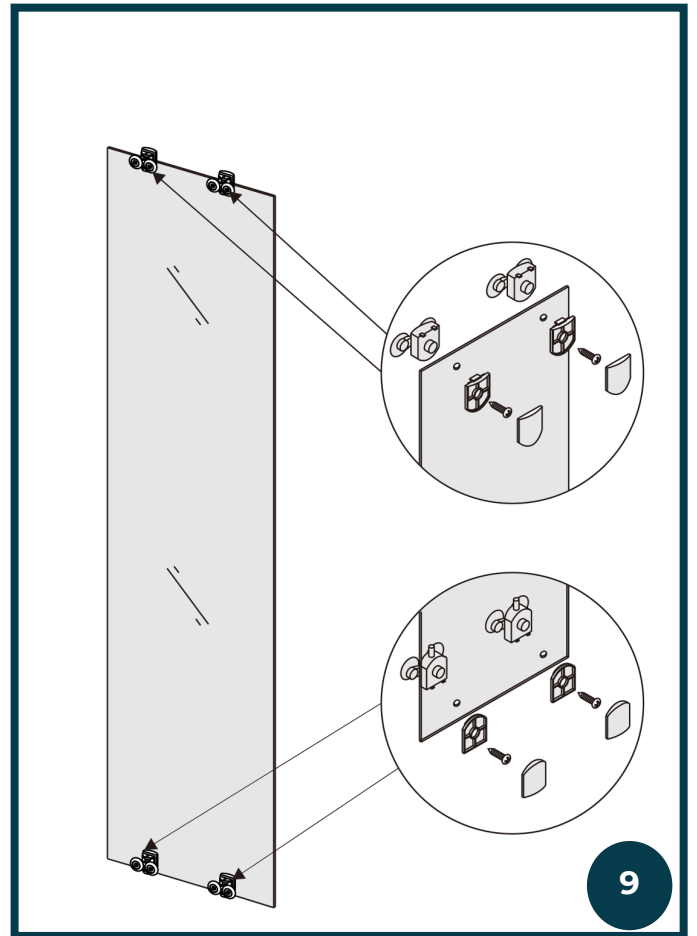

10° ÉTAPE

1. Accrochez les verres au rail de coulissement. . Assurez-vous que la porte soit sur axe, voyez l'étape précédent por régler le roulements.

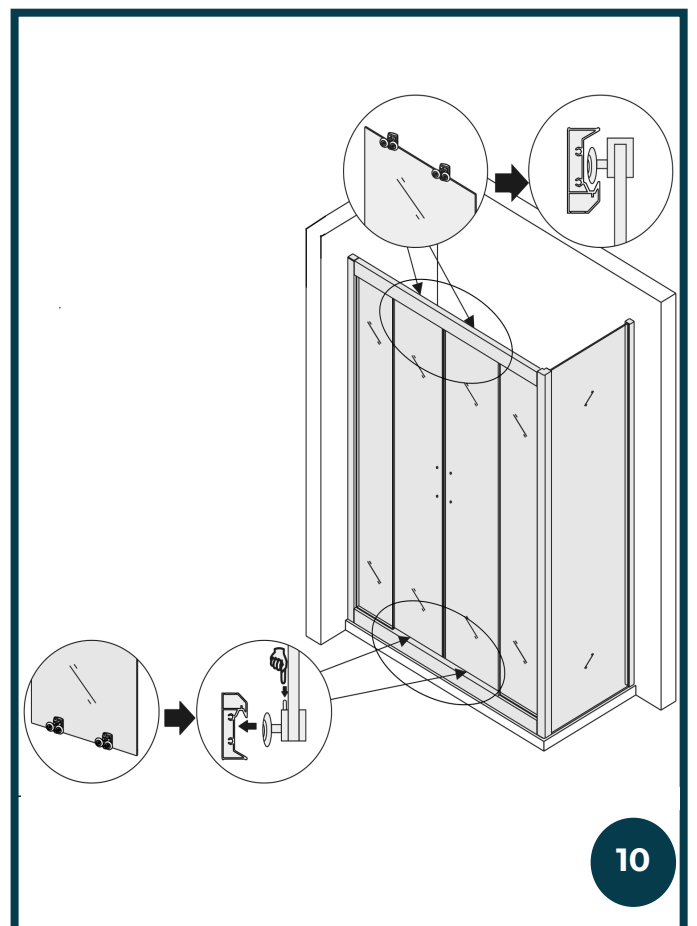

11° ÉTAPE

1. Installez le joint magnétique d'arrêt sur le verre .
2. Installez les joints qui bloquent le verre entre le profilé en aluminium et le verre.

Vous la trouverez enroulée dans un paquet!!!

3. Vérifier la mise à plombe, faites les trous et appliquez la vis par l'intérieur pour bloquer la paroi au profilé mural. Après cette étape, recouvrez avec le profilé de couverture (H. 190 cm qui cache le profilé mural et occulte les fixages).

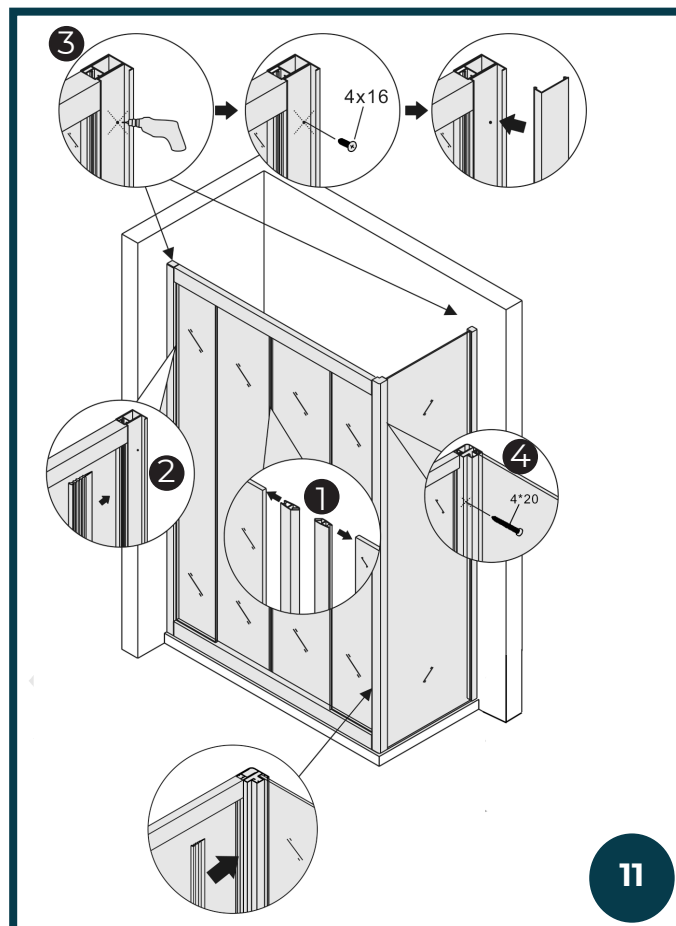

12° ÉTAPE

1. Installez le cutée sur le rail supérieur et inférieur. Utilisez les vis plus petits en dotations. Si seront utilisés les vis plus grandes, le rail se va à dégrader sur la côté frontale.
2. Installez le poignée.
3. Installez le joint d'étanchéité entre le mur fixe et la porte coulissante .

ATTENTION:

En dotation vous trouverez un joint plus petit et un plus grande. Cela plus petit, doit être installé sur le verre fixe, cela plus grande, sur le verre coulissante.

4. Installez les capuchons de couverture sur la partie supérieure du profilé en aluminium et mettez le silicone sur la partie extérieure de la porte long du périmètre selon l'illustration.

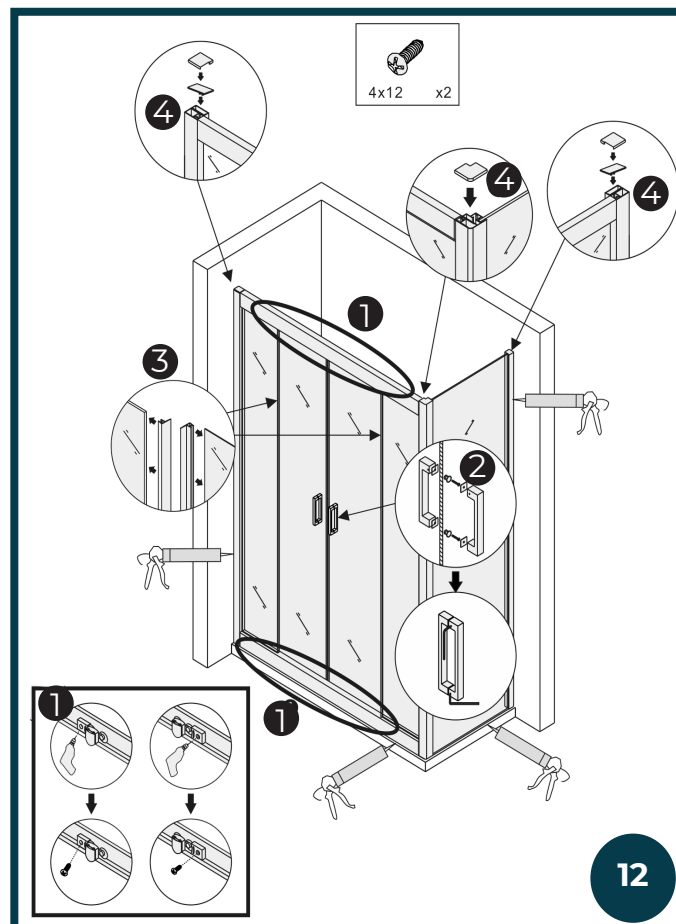

Laneri

sanitary ware

c/da Gentilomo snc
94100 Enna Italy
www.laneribagni.it

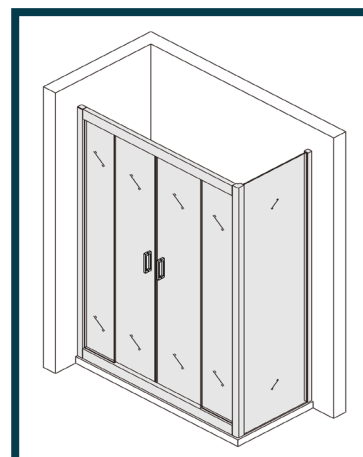
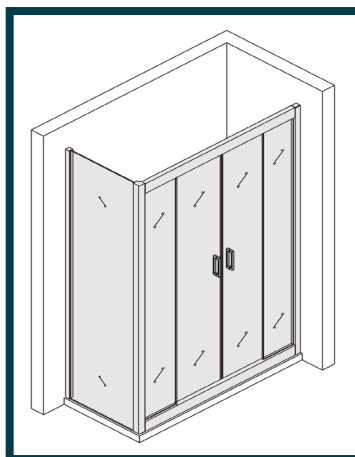

Manhattan 2.0

BESCHREIBUNG

Duschkabine mit Schiebtür, zentraler Öffnung und passender fester Seitenwand. Hergestellt aus 6 mm gehärtetem Glas, Höhe 190 cm. Beidseitig einbaubar. Möglichkeit der Schnellentriegelung der unteren Schieberollen. Manuelle Anpassung der Wandelemente von 2,5 cm pro Seite. Gestell aus verchromtem Aluminium, Glas mit Anti-Kalk-Behandlung, gekennzeichnet durch spezielle grüne Etiketten.

TECHNISCHE BESCHREIBUNG

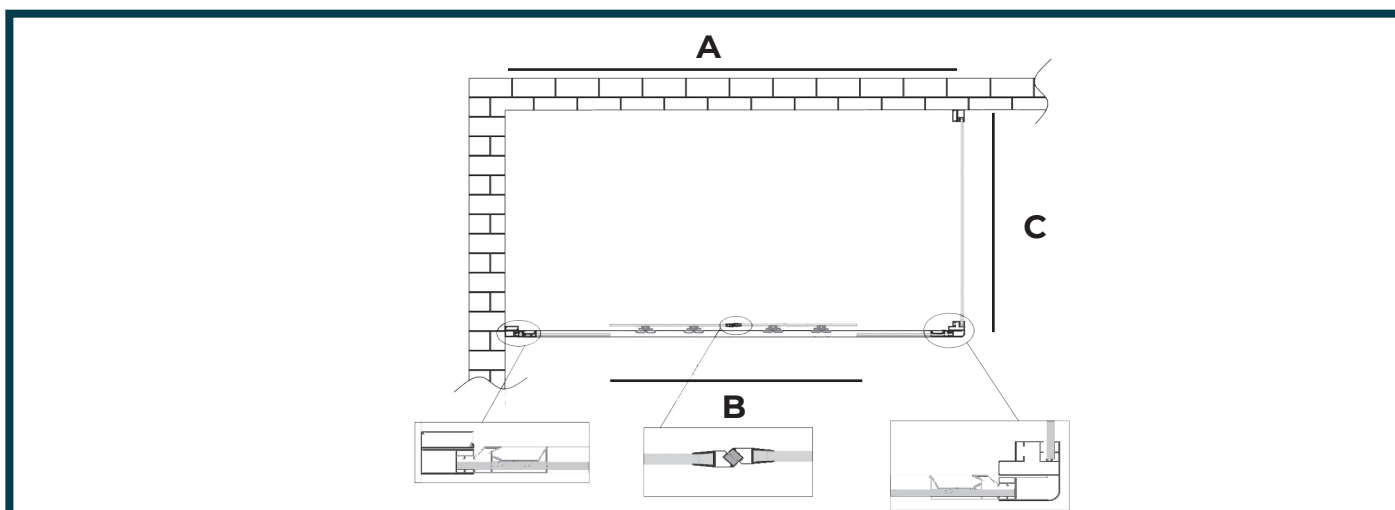

DETAILS ZUBEHÖR

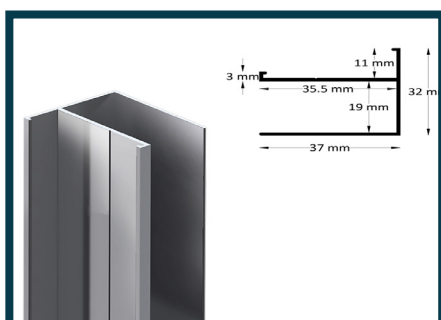

Festes Wandelement

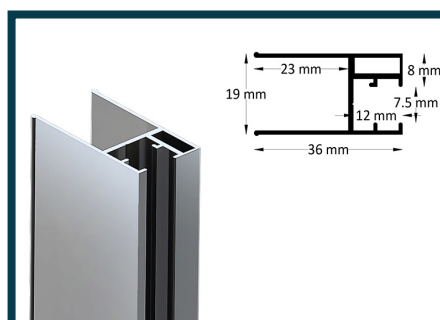

Festes Glaselement

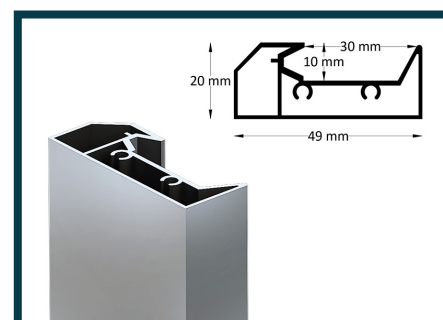

Radschienelement

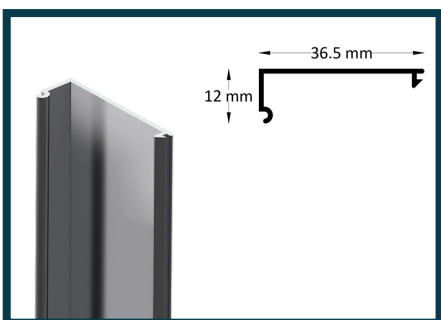

Abdeckelement

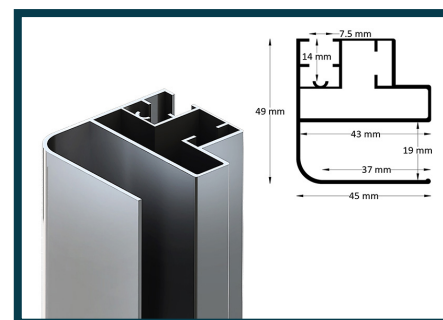

Eckelement

Laneri®

sanitary ware

c/da Gentilomo snc
94100 Enna Italy
www.laneribagni.it

Manhattan 2.0

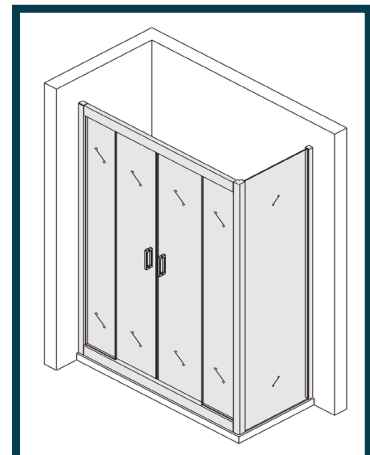
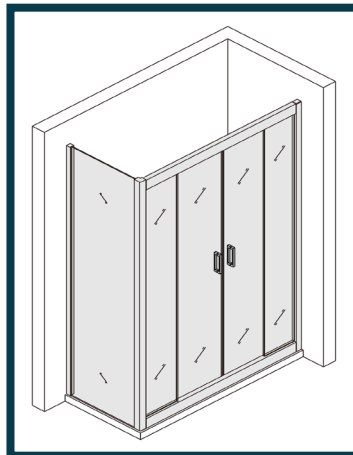

TÜRGRÖSSE	ABMESSUNGEN	
	A	B
130 (Seitenlänge 120)	1280 - 1330	560
135 (Seitenlänge 125)	1330 - 1380	535
140 (Seitenlänge 130)	1380 - 1430	610
145 (Seitenlänge 135)	1430 - 1480	585
150 (Seitenlänge 140)	1480 - 1530	660
155 (Seitenlänge 145)	1530 - 1580	535
160 (Seitenlänge 150)	1580 - 1630	610
165 (Seitenlänge 155)	1630 - 1680	685
170 (Seitenlänge 160)	1680 - 1730	760
175 (Seitenlänge 165)	1730 - 1780	635
180 (Seitenlänge 170)	1780 - 1830	710
185 (Seitenlänge 175)	1830 - 1880	785
190 (Seitenlänge 180)	1880 - 1930	860
195 (Seitenlänge 185)	1930 - 1980	735
200 (Seitenlänge 190)	1980 - 2030	810
205 (Seitenlänge 195)	2030 - 2080	885
210 (Seitenlänge 200)	2080 - 2130	960

GRÖSSE FESTE SEITENWAND	ABMESSUNGEN	
	C	
65	625 - 650	
67,5	650 - 675	
70	675 - 700	
75	725 - 750	
80	775 - 800	
90	875 - 900	
100	975 - 1000	

MANHATTAN 2.0

BENÖTIGTE WERKZEUGE



Bleistift

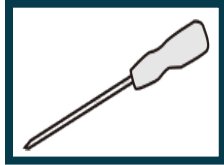

Schraubendreher

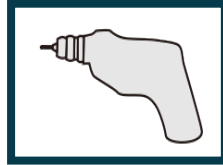

Bohrer



Maßband

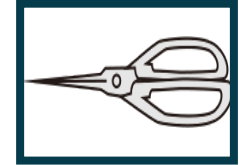

Schere

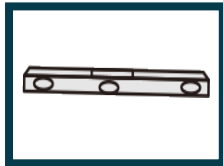

Wasserwaage



Sechskantschlüssel
(mitgeliefert)

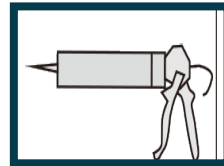

Silikon

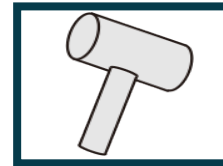

Gummihammer

PAKETINHALT

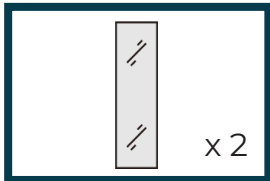

Festes Glas

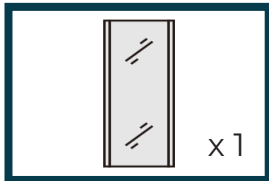

Feste Glaswand
H 1,90

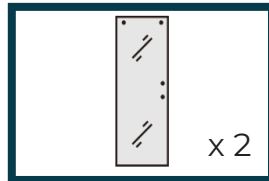

Schiebeglas

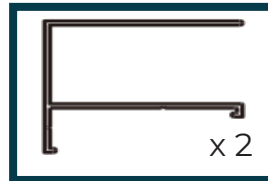

Wandelement
H 1,90

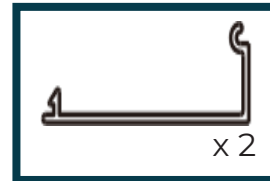

Wandelementab-
deckung H 1,90

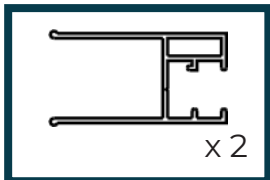

Festes Glaselement



Gleitschiene

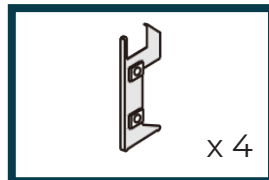

Fester Seitenver-
binder mit Schlitz



Schrauben 4 x 10
Enddichtung

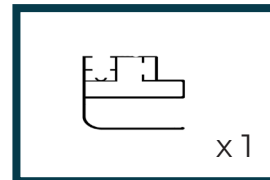

Winkel-
element
H 1,90



Abnehmbare untere
Räder

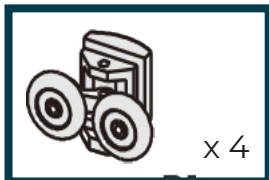

Obere Räder

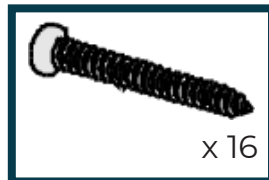

Schrauben 4 x 30

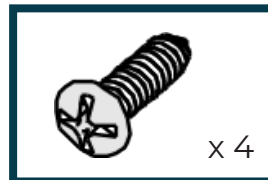

Schrauben 4 x 16



Schrauben 4 x 12

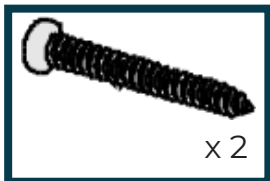

Schrauben 4 x 20

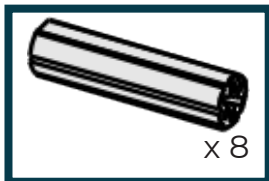

Dübel

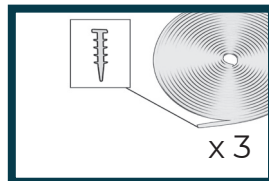

Rollendichtung mit
Glasstopp

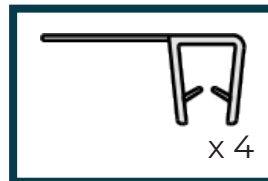

Spritzschutz-
dichtung

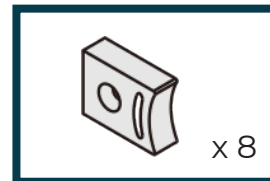

Enddichtung

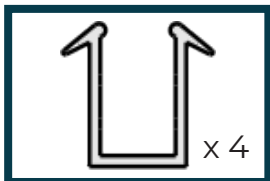

Glasschutz-
dichtung

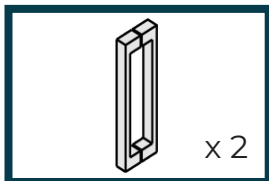

Griffe

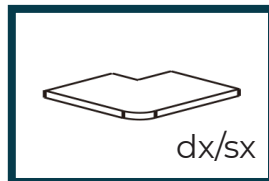

Eckelementab-
deckung

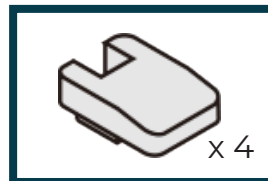

Abdeckung



Magnetdichtung

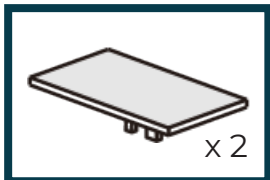

Obere Abdeckung mit
festem Glasanschlag

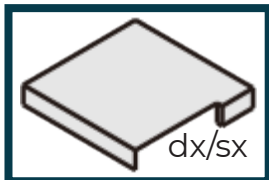

Obere Wandele-
mentabdeckung

MONTAGE

1. SCHRITT

1. Stellen Sie mit Hilfe der Wasserwaage sicher, dass die Duschwanne eben ist.
2. Platzieren Sie das Element an der Wand und verwenden Sie die Wasserwaage zum senkrechten Stellen.
3. Markieren Sie die Löcher mit dem Bleistift auf der Wand.
4. Bohren Sie mit dem Bohrer die Löcher in die Wand.
5. Setzen Sie den Dübel ein und schrauben Sie die Schrauben fest, um das Element zu befestigen.

WICHTIG

Es wird empfohlen, die Elemente nicht direkt an der Außenkante der Duschwanne anzubringen, immer etwa 1 cm Abstand lassen für ein optimales ästhetisches Ergebnis

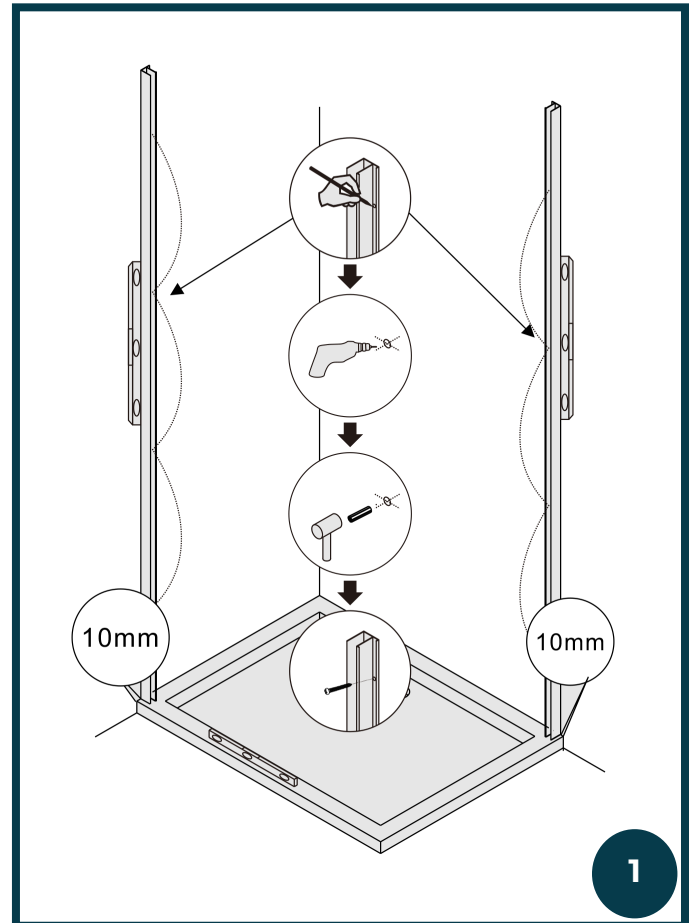

2. SCHRITT

1. Verwenden Sie eine 4x30 Schraube, um die untere Aluminiumschiene mit dem vertikalen Element zu verbinden. Auf diese Weise bauen wir den Türrahmen (Gerüst).
- VERWENDEN SIE DIE VERBINDER MIT SCHLITZ (X2), UM DEN HORIZONTALEN RAHMEN MIT DEM VERTIKALEN RAHMEN ZU VERBINDEN.

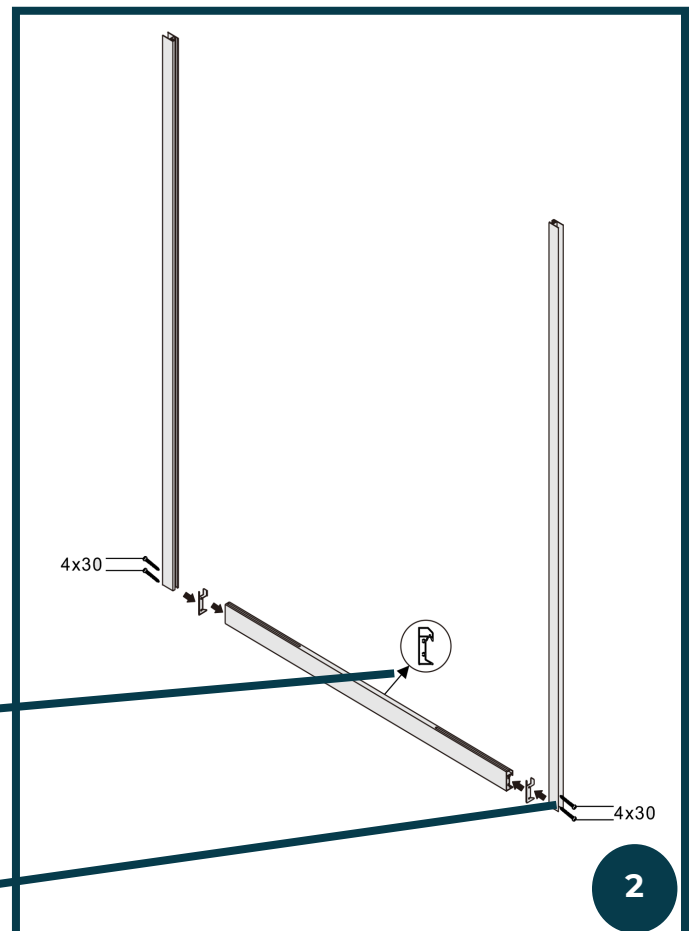
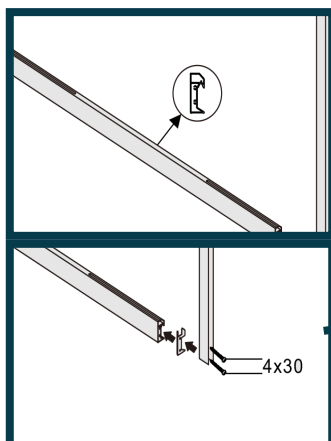

3. SCHRITT

1. Legen Sie die Kunststoffteile wie in Abbildung A in die Aluminiumschiene ein. (Abdeckung)
2. Setzen Sie die Dichtung in das untere Element ein. Wie in Abbildung A. (Glasschutzdichtung)
3. Setzen Sie das feststehende Glas wie in Abbildung B ein.

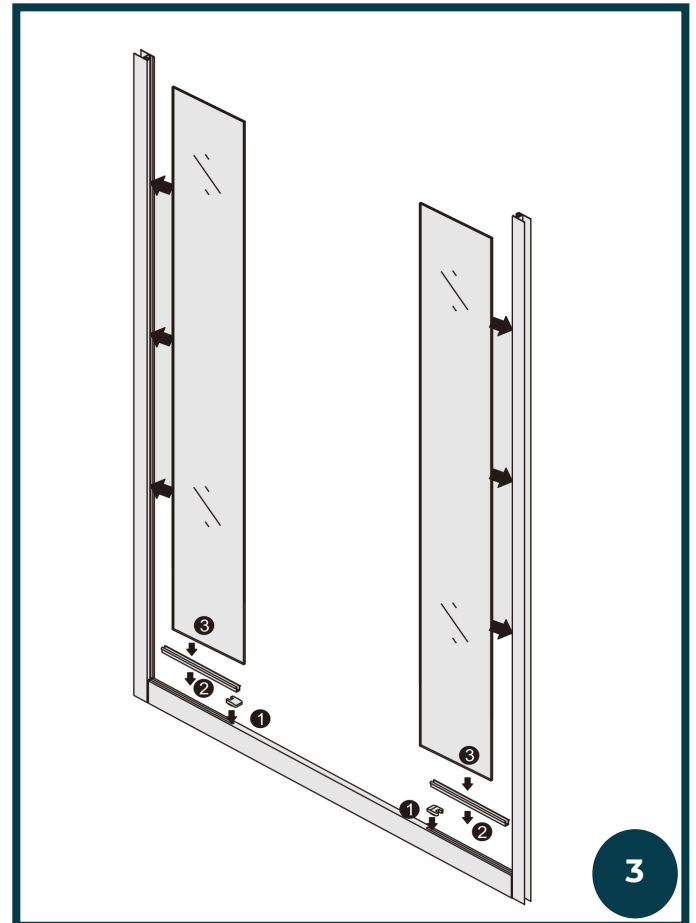
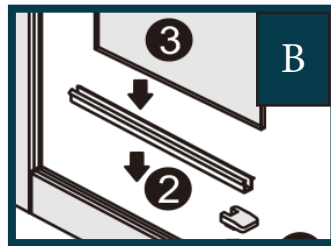
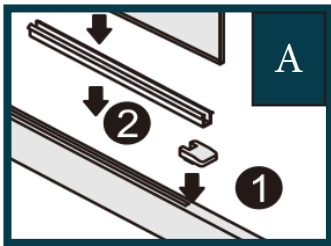

4. SCHRITT

1. Wiederholen Sie den vorhergehenden Schritt (2 und 3) für den oberen Teil des Rahmens

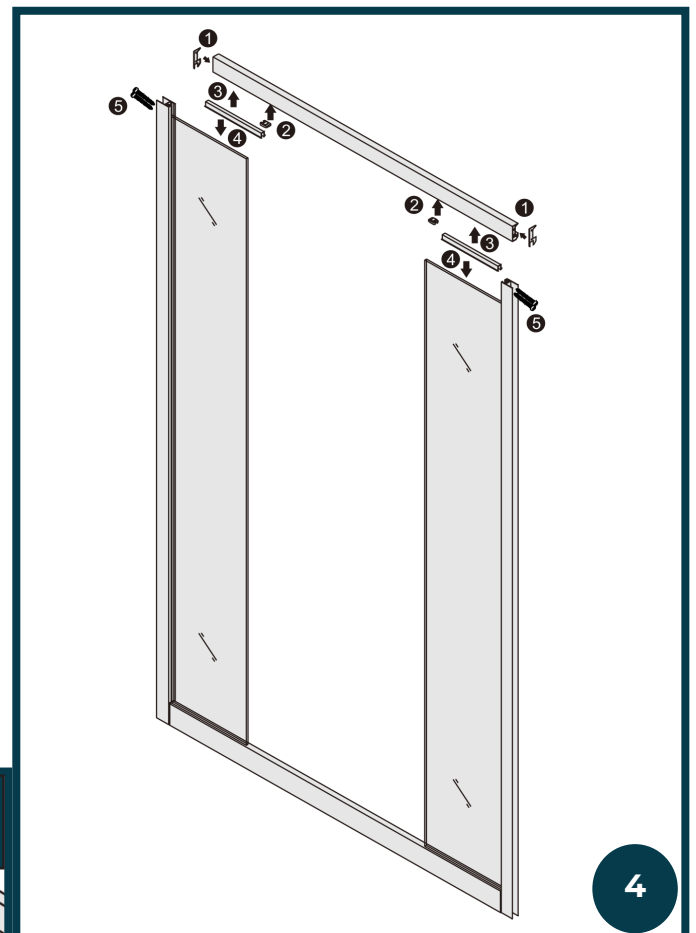
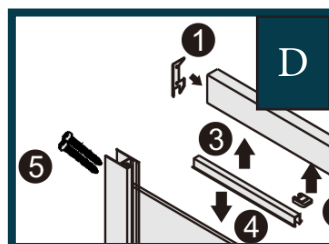
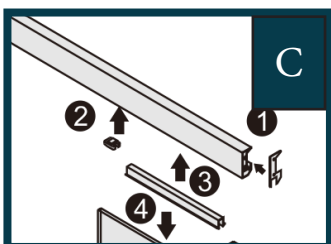

5. SCHRITT

1. Setzen Sie den zuvor montierten Rahmen in das Wandelement ein.
2. Passen Sie die Verlängerung des Rahmens an, indem Sie die Elemente zusammenschieben (1 Element passt in das andere rein)

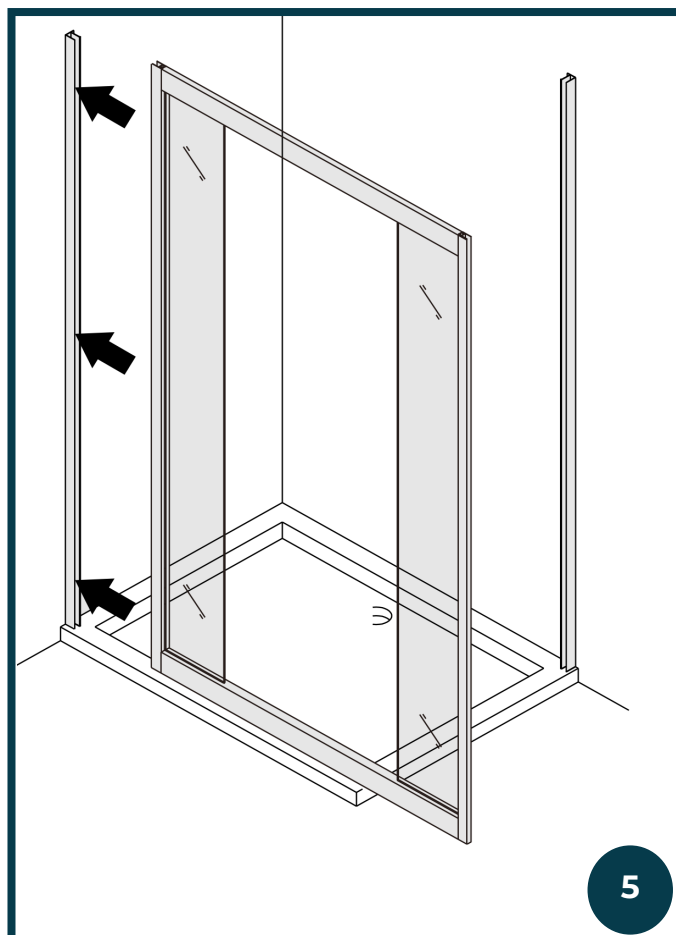

6. SCHRITT

1. Tragen Sie das Silikon in die Einbuchtung des Eckelementes auf.
2. Setzen Sie das feste Glas in das Eckelement ein und führen Sie während es noch frisch ist, den nächsten Schritt (7) aus.

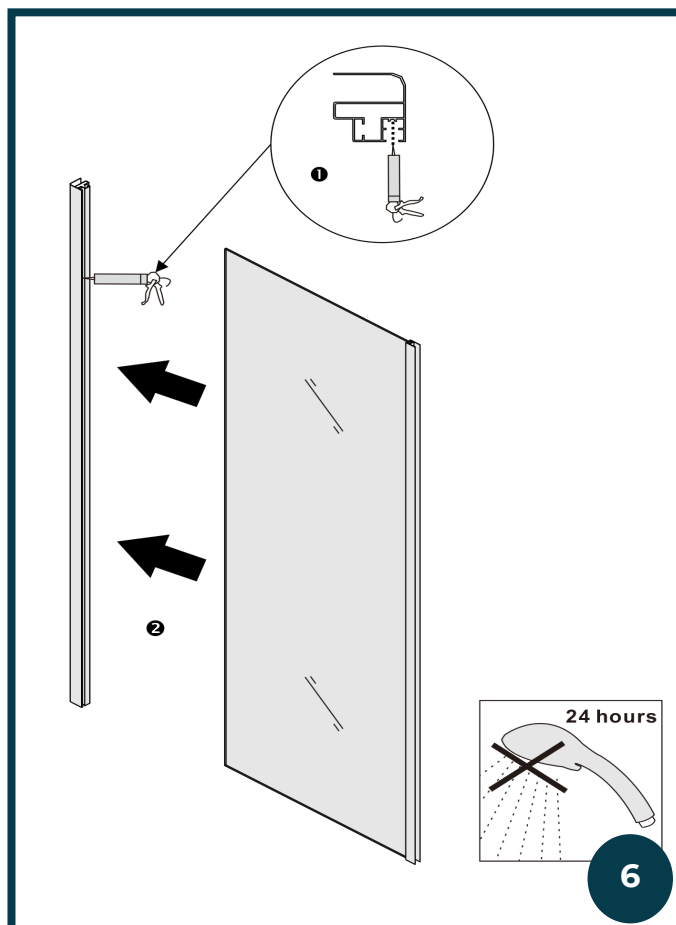

7. SCHRITT

1. Setzen Sie die Glasanschlagdichtung schräg zwischen Glas und Aluminiumelement ein und achten Sie darauf, dass sie von unten nach oben eingesetzt wird.
2. Die zu verwendende Dichtung ist die im Beutel aufgerollte, sie wird durch den Druck zwischen Glas und Rahmen eingelegt.

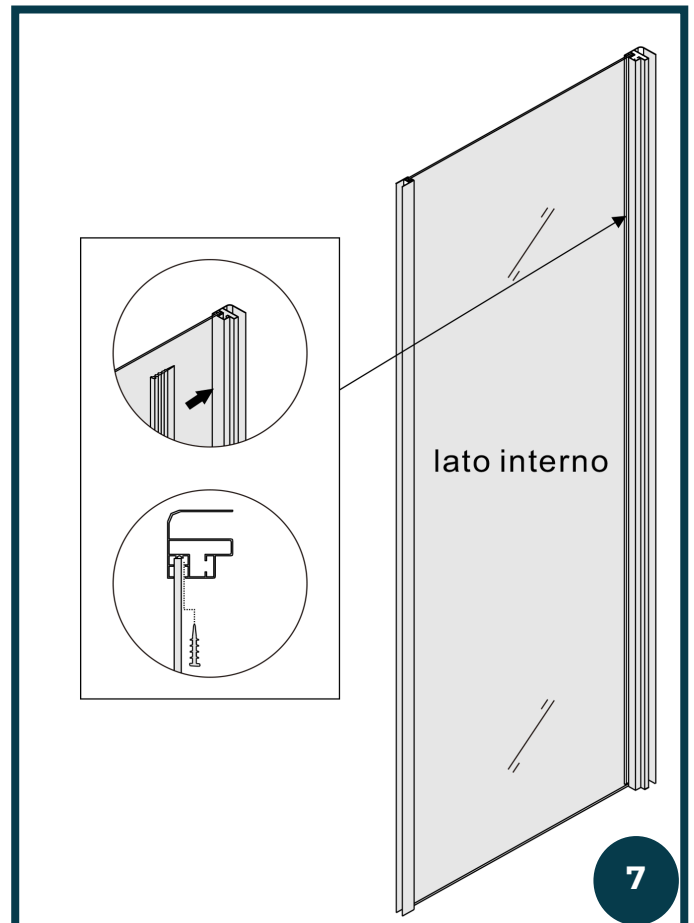

8. SCHRITT

1. Setzen Sie die feste Seitenwand zwischen das Wand- und Aluminiumeckprofil der Tür ein.

BITTE BEACHTEN SIE:

Unter der festen Glaswand ist kein weiterer Platz, sie wird eingesetzt und außen wird Silikon aufgetragen.

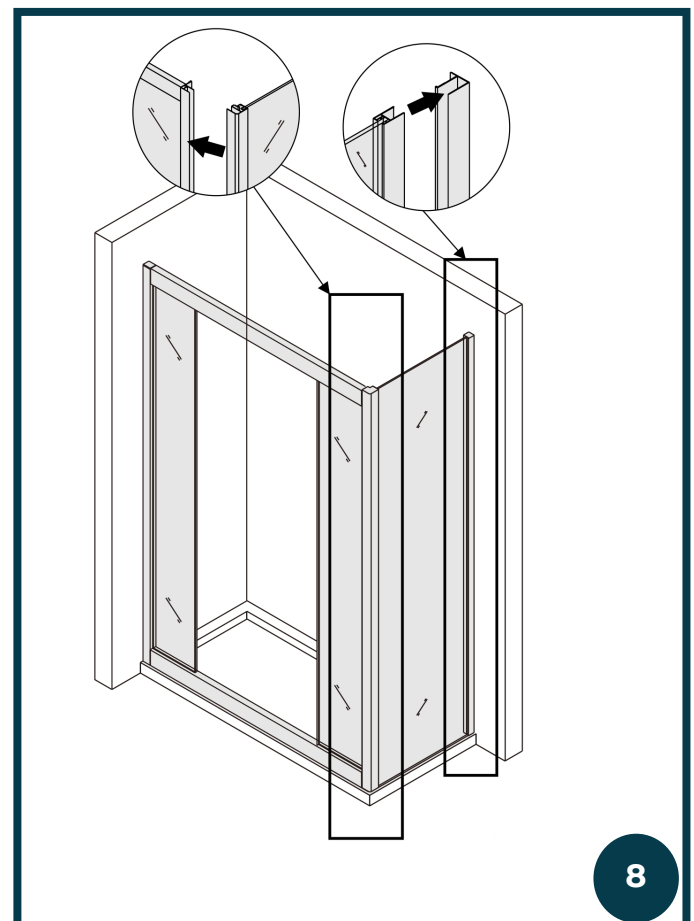

SCHRITT 9

1. Montieren Sie die unteren (mit Schnellverschlussdruckknopf) und die oberen Rädchen.

Hinweis : Die **oberen Räder** sind verstellbar. Wenn die Türen nach der Montage der Duschkabine nicht leichtgängig sind, können sie mit der unteren Schraube am oberen Lager eingestellt werden.

Die unteren Gleiträder sind abnehmbar, um routinemäßige Reinigungs- und Wartungsarbeiten zu erleichtern.

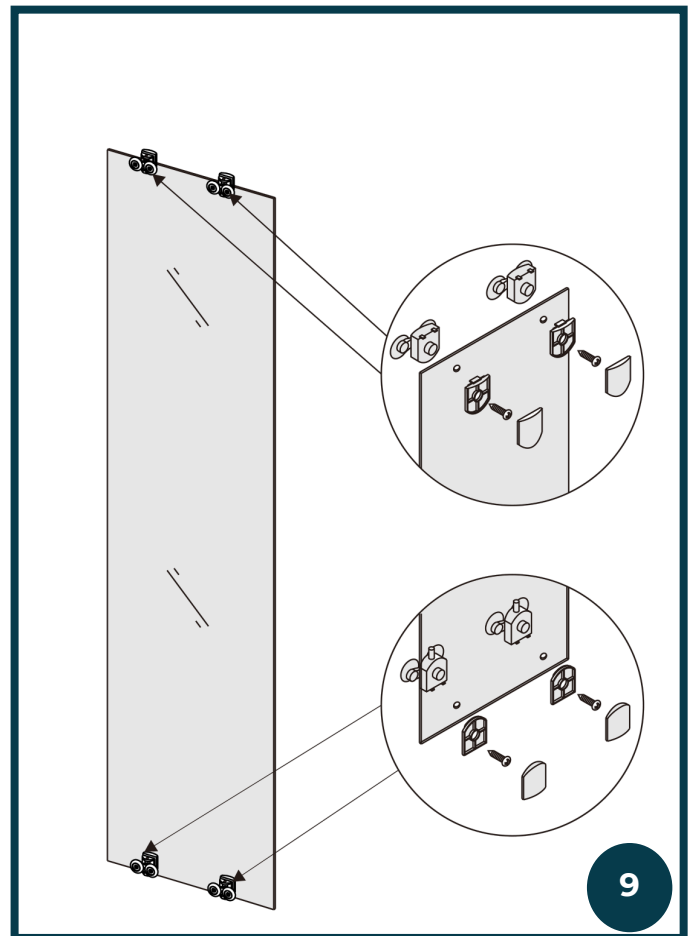

10. SCHRITT

1. Hängen Sie die Türen in die Gleitschiene ein. Stellen Sie sicher, dass die Tür ausgerichtet ist, siehe vorherigen Schritt, um sie anzupassen.

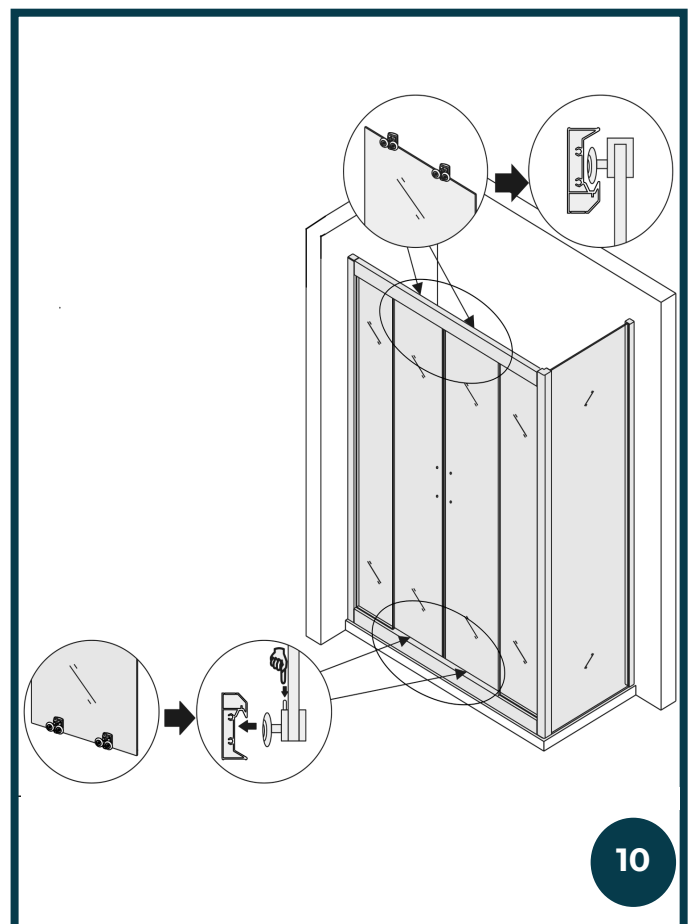

11. SCHRITT

1. Bringen Sie die magnetischen Verschlussdichtungen am Glas an.
2. Legen Sie die Flachdichtung zwischen Festglas und Aluminiumelement (Innenseite) ein.

Sie finden diese aufgerollt in einem Beutel !!

3. Überprüfen Sie die Rohrleitungen, bohren dann Löcher und bringen die Schraube von innen an, um die Wand am Wandelement zu befestigen, decken Sie dann alles mit dem dekorativen Aluminiumelement ab (190 cm hoher Deckel, der das Wandelement verkleidet und die Befestigungen verdeckt)

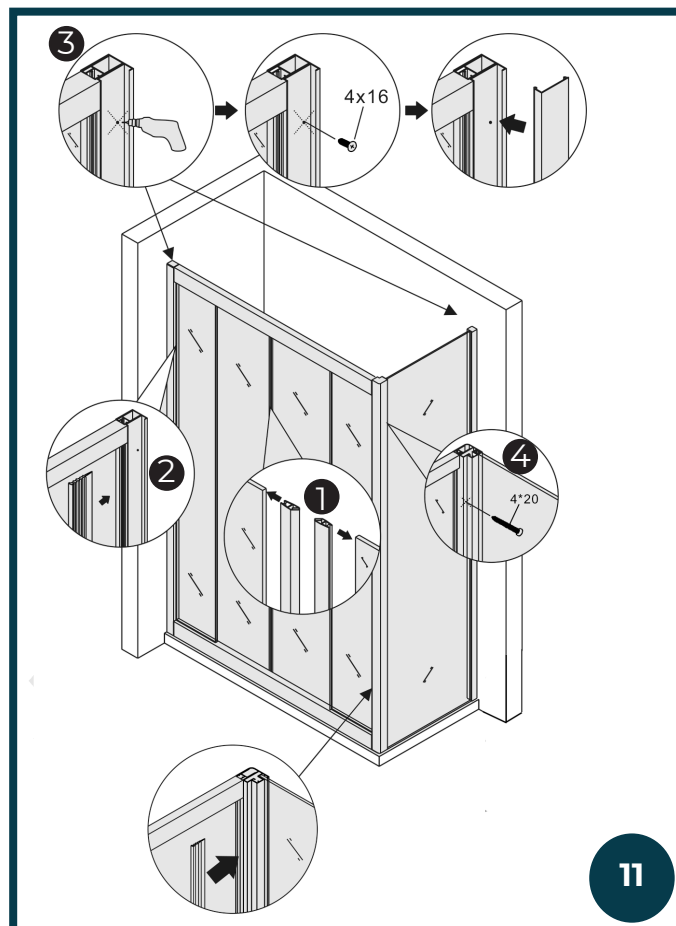

12. SCHRITT

1. Montieren Sie das Endelement oben und unten an der Schiene. Verwenden Sie die mitgelieferten kleineren Schrauben, sonst besteht die Gefahr, dass die Sichtseite der Laufschiene durchstoßen wird.
2. Montieren Sie den Griff.
3. Installieren Sie die Dichtung zwischen dem festen Glas und der Schiebetür.

BITTE BEACHTEN SIE

Im Lieferumfang ist eine höhere und eine untere Dichtung enthalten, die untere geht auf das Festglas, die höhere auf das Schiebeglas.

4. Montieren Sie die Abdeckkappen im oberen Teil des Aluminiumelementes und tragen Sie das Silikon auf den äußeren Teil der Duschkabine auf, entlang des gesamten Umfangs, wie in der Abbildung zu sehen.

