

**INSTRUCTION MANUAL/BEDIENUNGSANLEITUNG/NOTICE D'UTILISATION/
MANUAL DE INSTRUCCIONES DE USO/MANUALE DI ISTRUZIONI**

! WARNING!

Adults assembly required.
During assembly, keep all
parts away from children.
Check regularly to ensure
all fasteners are tight.

! WARNUNG!

Die Montage ist von
Erwachsenen durchzuführen.
Halten Sie während der
Montage alle Teile von Kindern
fern.
Überprüfen Sie regelmäßig
den festen Sitz der Schrauben.

! Attention!

Montage à effectuer par
des adultes.
Pendant le montage, tenez
les éléments
éloignés des enfants.
Vérifiez régulièrement que
toutes les vis
soient serrées.

! ¡Atención!

Se requiere que el montaje sea
llevado a cabo por un adulto.
Durante el montaje, mantenga
todas las piezas fuera del
alcance de los niños.
Verifique regularmente que
todos los tornillos estén
correctamente apretados.

! Avvertimento!

L'assemblaggio deve essere
effettuato da adulti.
Durante il montaggio
mantenere tutti i pezzi lontano
dalla portata dei bambini.
Controllare regolarmente per
assicurarsi che tutte le
chiusure siano ben strette.

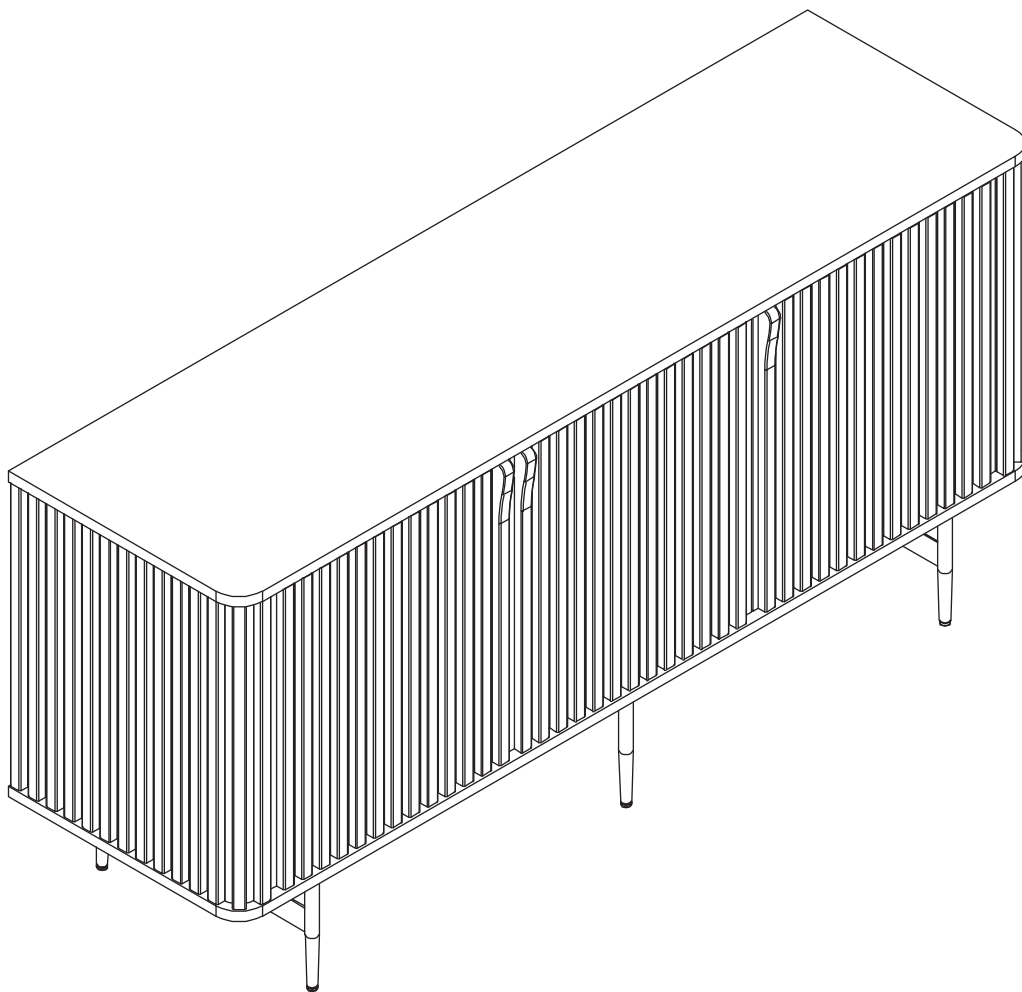







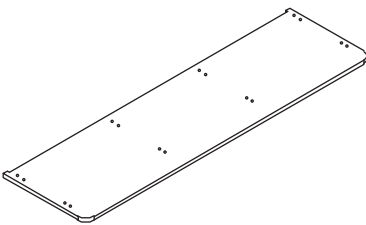
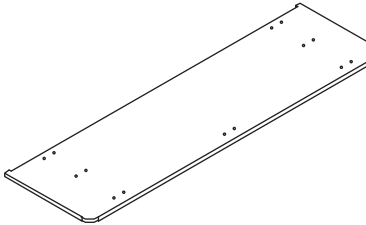
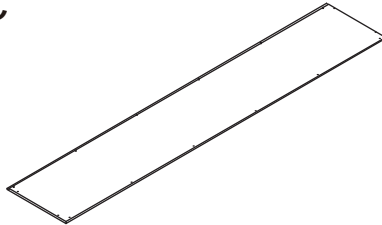

**RETAIN FOR FUTURE REFERENCE
FÜR KÜNFTIGE VERWENDUNG AUFBEWAHREN
A CONSERVER POUR UNE UTILISATION FUTURE
CONSERVAR PARA SER LEÍDO POR CADA NUEVO USUARIO,
ANTES DE UTILIZAR EL ARTÍCULO POR PRIMERA VEZ
CONSERVARE PER CONSULTAZIONI FUTURE**

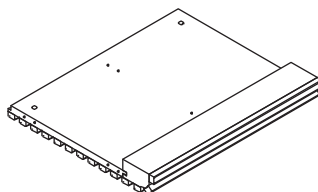
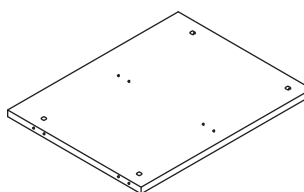
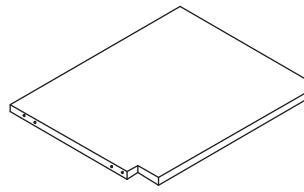
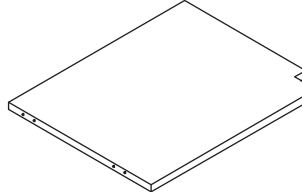
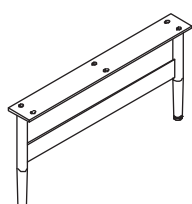
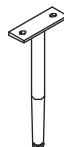
PARTS LIST/STÜCKLISTE/PARTS LIST/LISTA DE PIEZAS/LISTA DEI PEZZI

Carton A Karton A Carton A Caja A Contenitore A

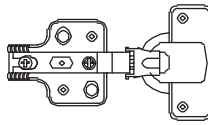
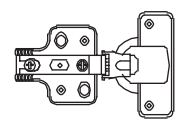
<p>A</p>  <p>1560x450x18mm 1pc</p>	<p>B</p>  <p>1560x450x18mm 1pc</p>	<p>C</p>  <p>1512x274x9mm 2pcs</p>
--	--	--

Carton B Karton B Carton B Caja B Contenitore B

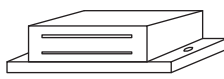
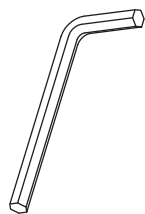
<p>D</p>  <p>514x363x18mm 2pcs</p>	<p>E</p>  <p>514x402x18mm 2pcs</p>	<p>G</p>  <p>498x402x18mm 1pc</p>	<p>I</p>  <p>498x402x18mm 1pc</p>
<p>L</p>  <p>2pcs</p>	<p>M</p>  <p>1pc</p>	<p>H1</p>  <p>28pcs</p>	<p>H2</p>  <p>28pcs</p>
<p>H3</p>  <p>28pcs</p>	<p>H4</p>  <p>4pcs</p>	<p>H5</p>  <p>2pcs</p>	<p>H6</p>  <p>ST3.5x16 54pcs</p>
<p>H7</p>  <p>ST3.5x25 26pcs</p>	<p>H8</p>  <p>M6x15 14pcs</p>	<p>H9</p>  <p>3pcs</p>	<p>H10</p>  <p>1pc</p>

Carton C Karton C Carton C Caja C Contenitore C

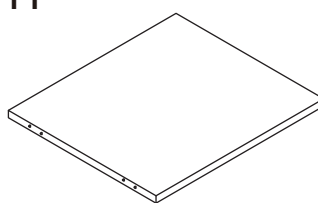
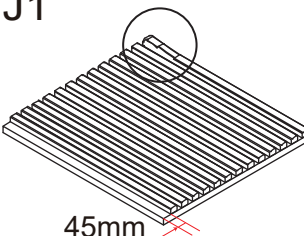
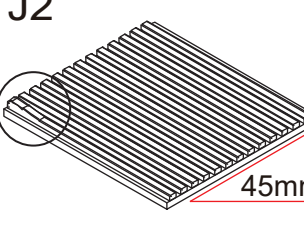
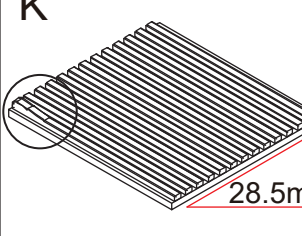
<p>H</p>  <p>458x402x18mm 1pc</p>	<p>J1</p>  <p>45mm 1pc</p>	<p>J2</p>  <p>45mm 1pc</p>	<p>K</p>  <p>28.5mm 1pc</p>
---	--	---	---



Warning!

Warnung!

Attention !

Atención!

Avvertimento!

Tight all the screws to 60% first then tight to 100%.

Während der Montage alle Schrauben zuerst 60% anziehen, dann zu 100%.

Serrez toutes les vis à 60% d'abord puis serrez à 100%.

Primero apriete los tornillos al 60% y después al 100%.

Stringere le viti dapprima al 60% e successivamente completamente al 100%.

ASSEMBLY/MONTAGE/ASSEMBLAGE/MONTAJE/ASSEMBLAGGIO

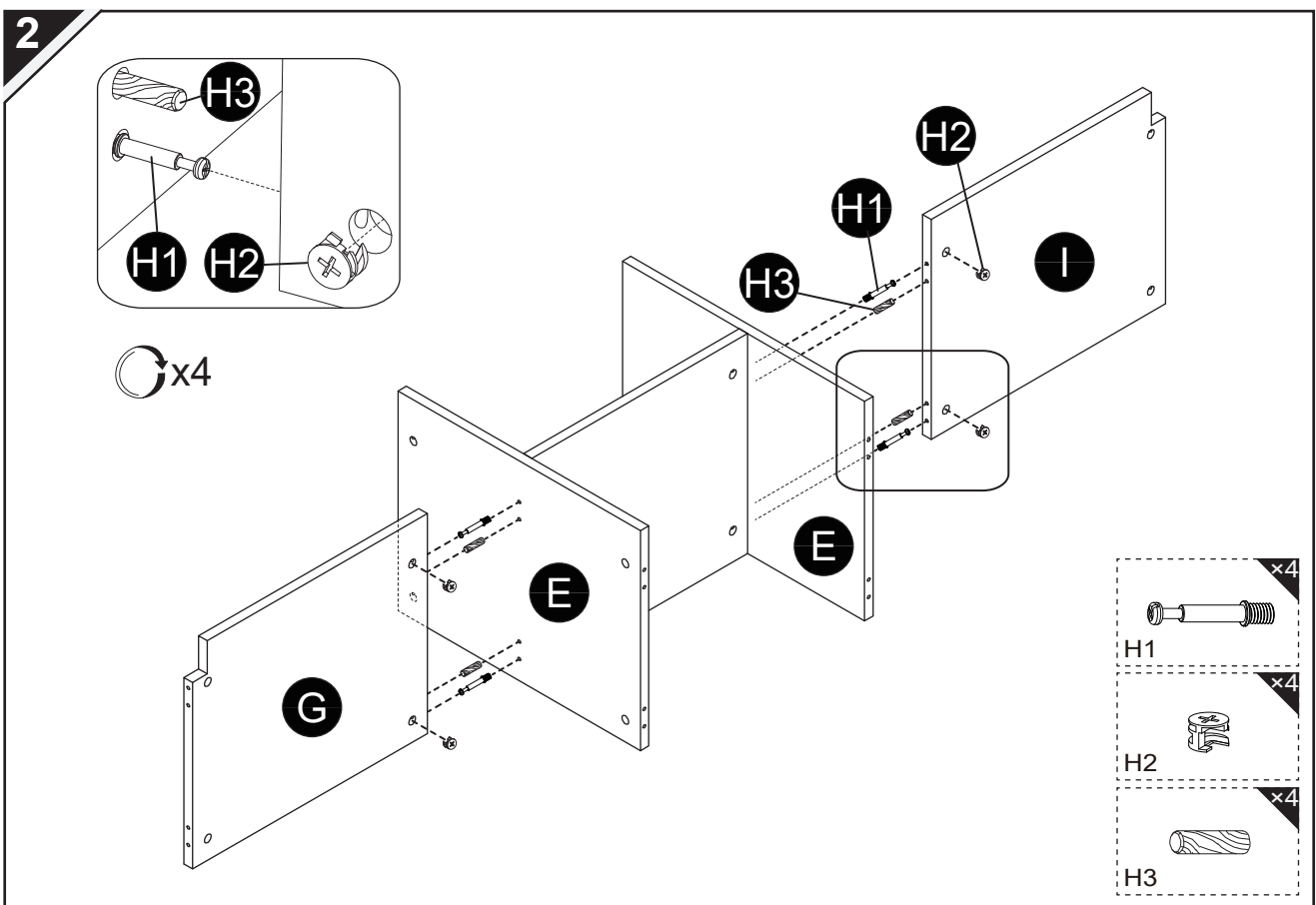
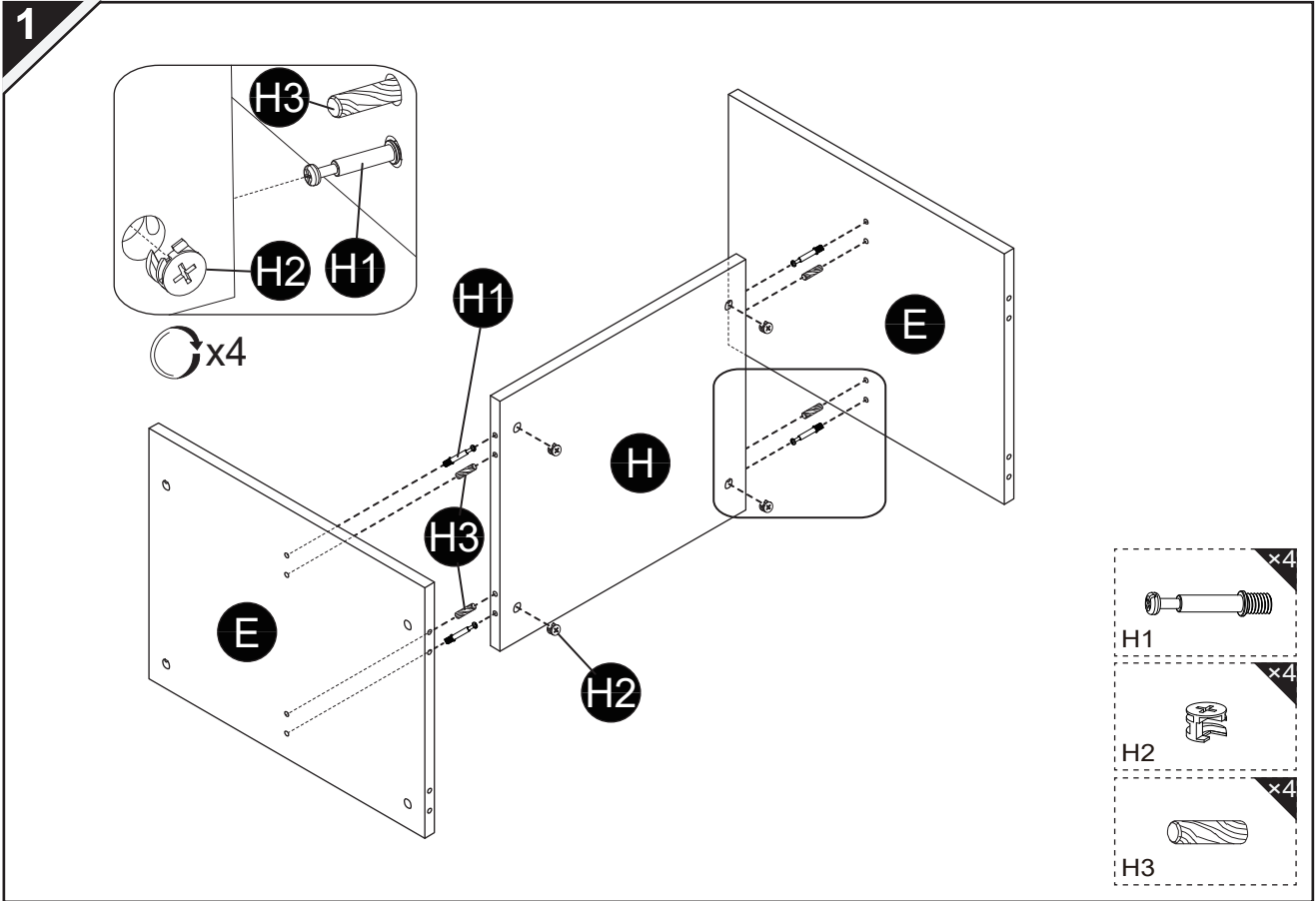



Warning!
Warnung!
Attention !
Atención!
Avvertimento!

Tight all the screws to 60% first then tight to 100%.
Während der Montage alle Schrauben zuerst 60% anziehen, dann zu 100%.
Serrez toutes les vis à 60% d'abord puis serrez à 100%.
Primero apriete los tornillos al 60% y después al 100%.
Stringere le viti dapprima al 60% e successivamente completamente al 100%.

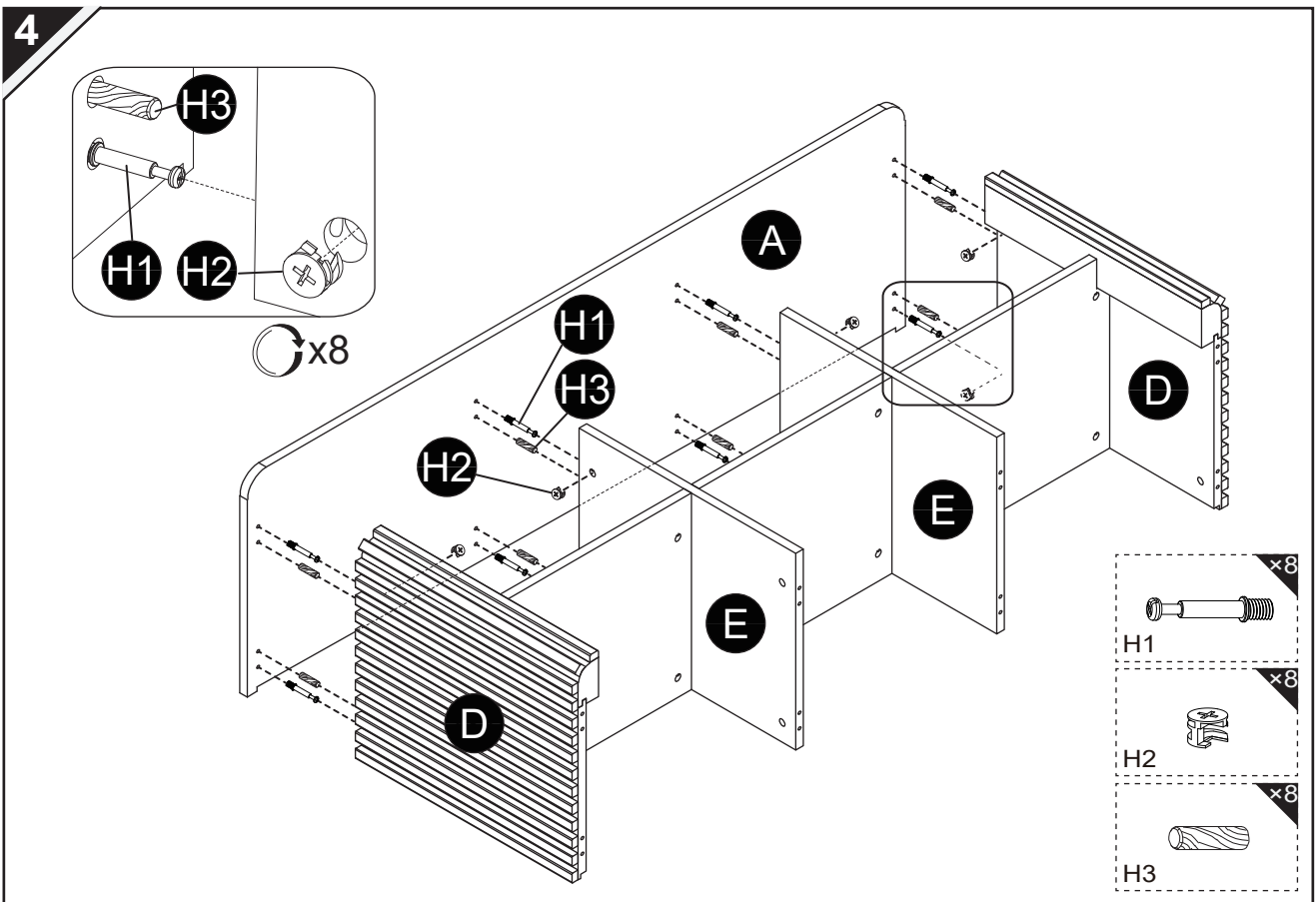
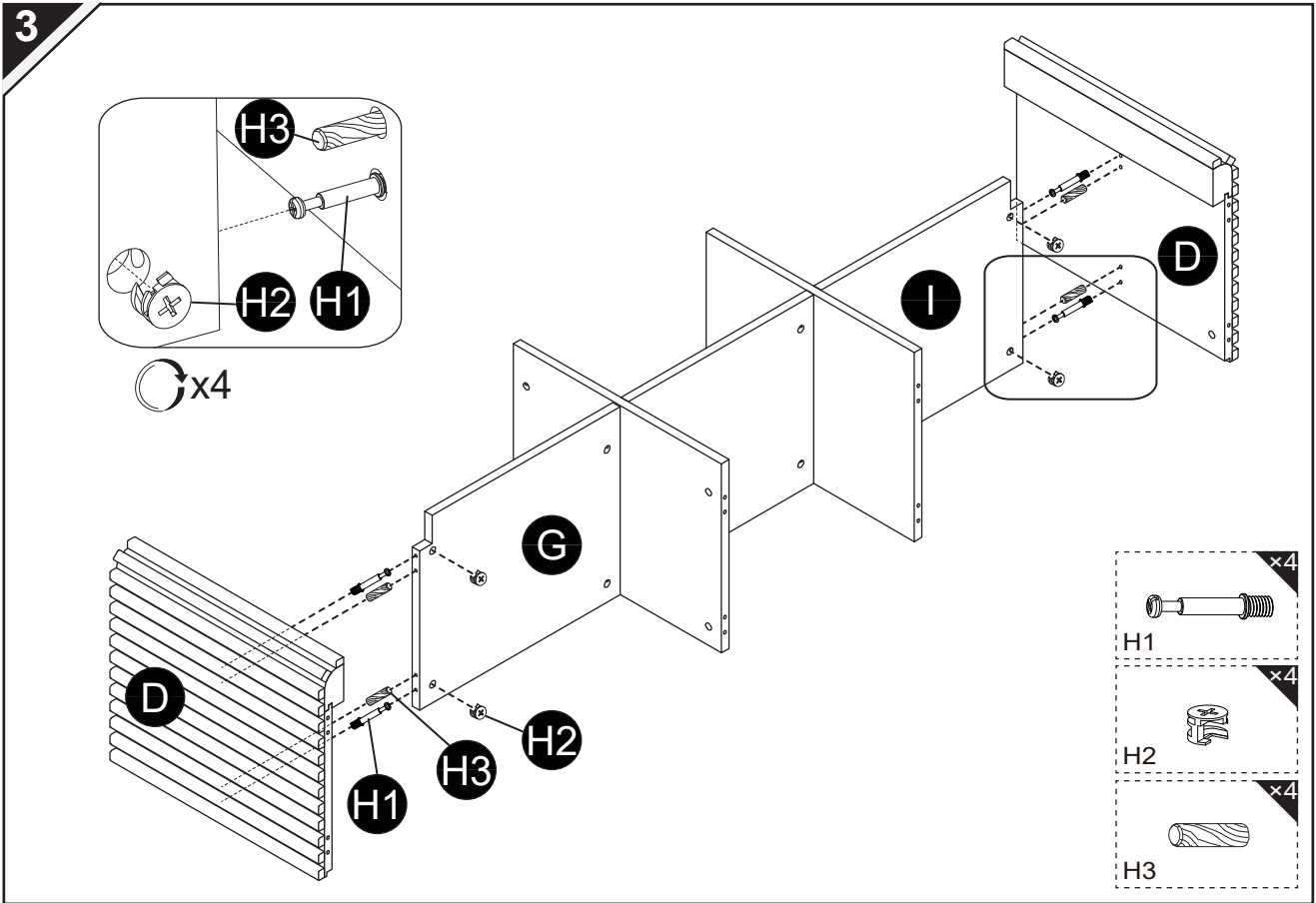



Warning!
Warnung!
Attention !
Atención!
Avvertimento!

Tight all the screws to 60% first then tight to 100%.
Während der Montage alle Schrauben zuerst 60% anziehen, dann zu 100%.
Serrez toutes les vis à 60% d'abord puis serrez à 100%.
Primero apriete los tornillos al 60% y después al 100%.
Stringere le viti dapprima al 60% e successivamente completamente al 100%.

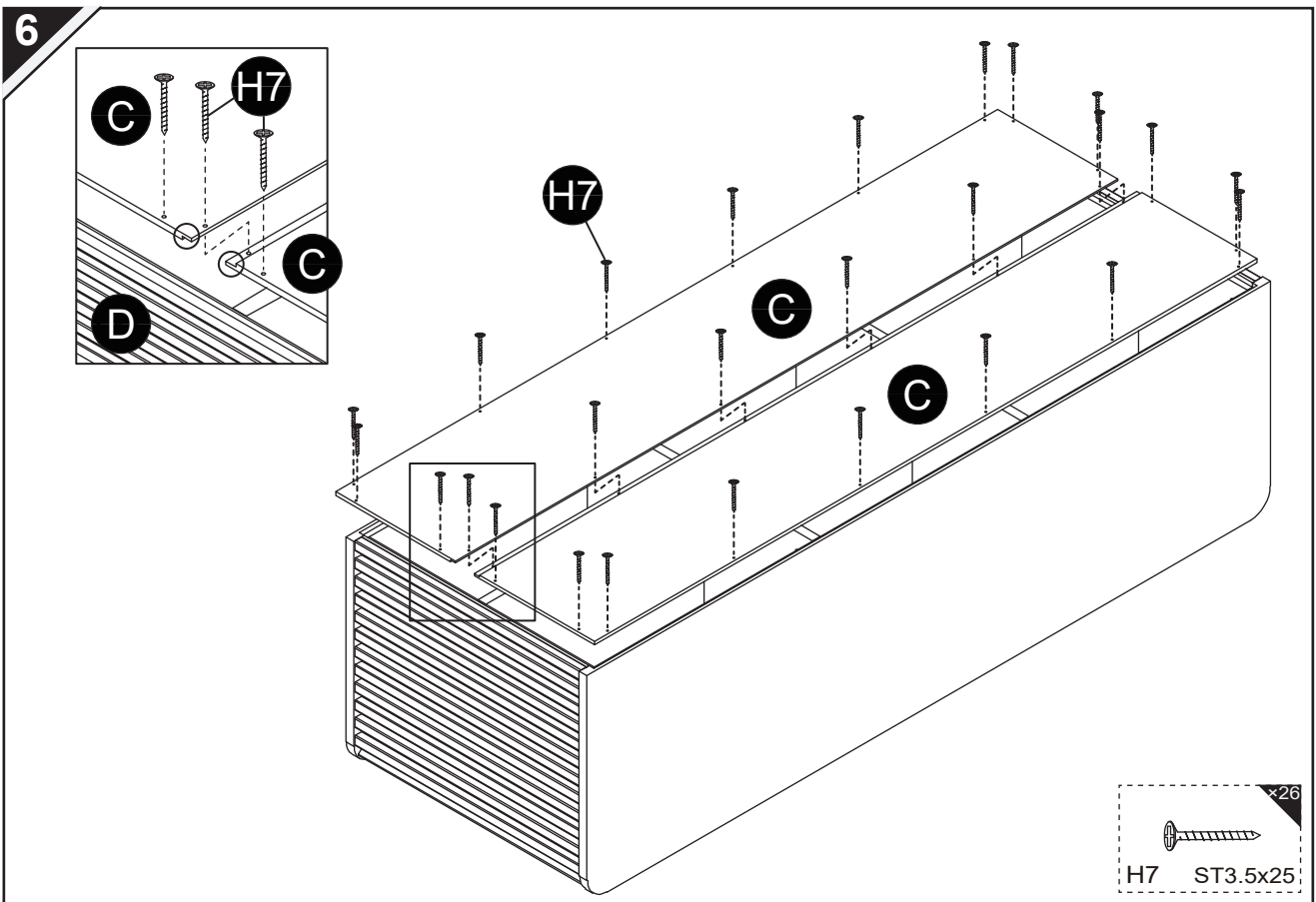
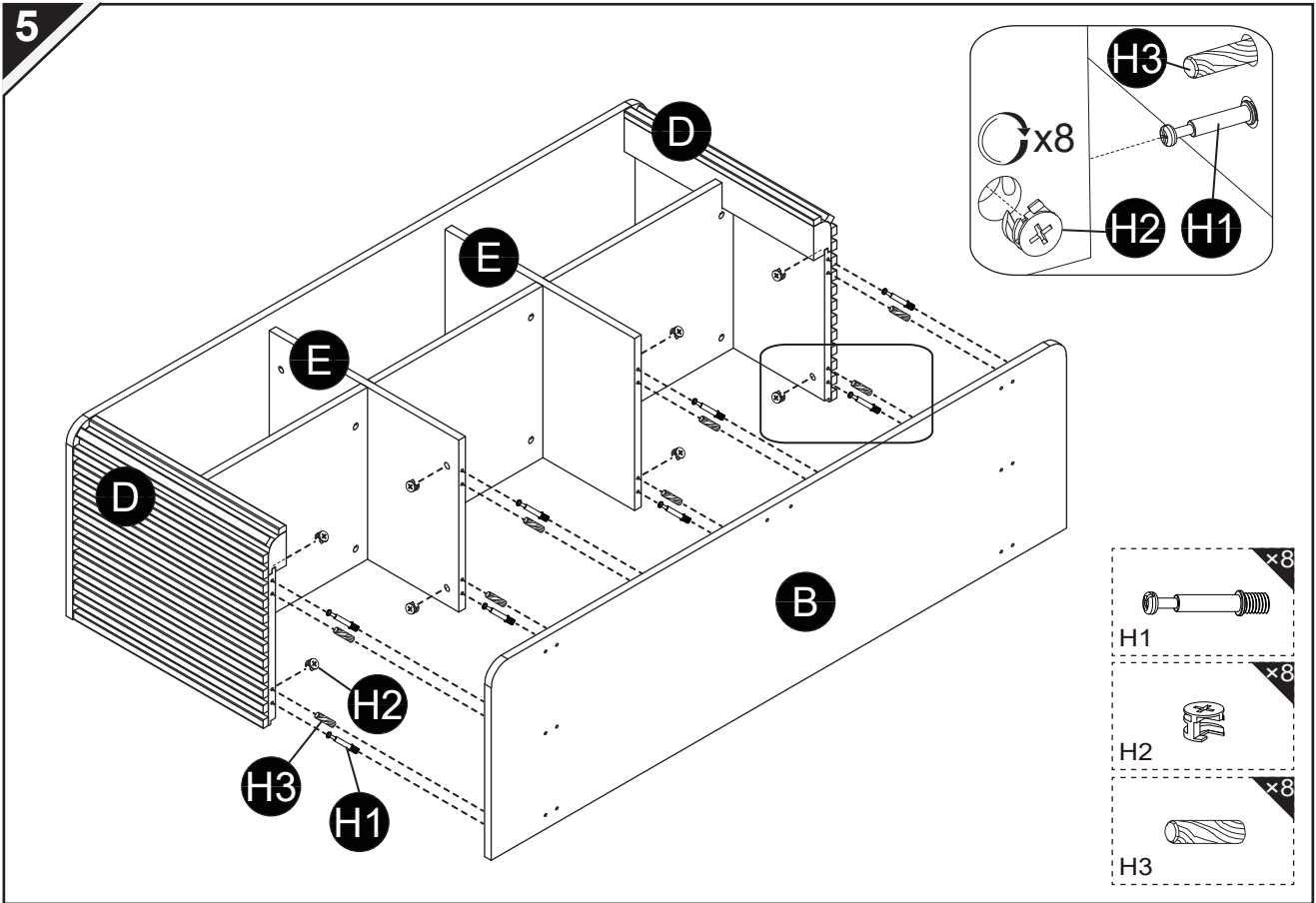



Warning!
Warnung!
Attention !
Atención!
Avvertimento!

Tight all the screws to 60% first then tight to 100%.
Während der Montage alle Schrauben zuerst 60% anziehen, dann zu 100%.
Serrez toutes les vis à 60% d'abord puis serrez à 100%.
Primero apriete los tornillos al 60% y después al 100%.
Stringere le viti dapprima al 60% e successivamente completamente al 100%.

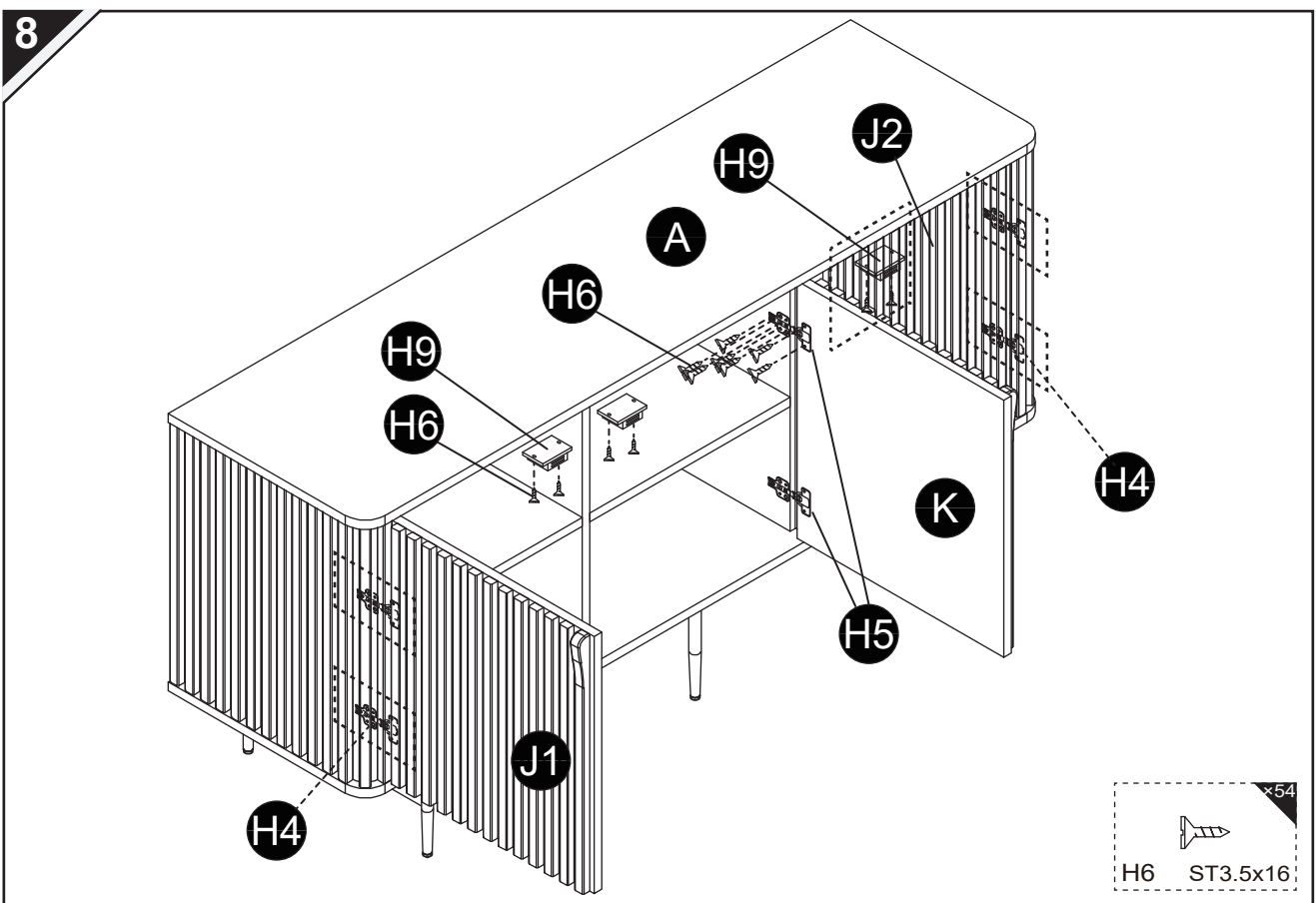
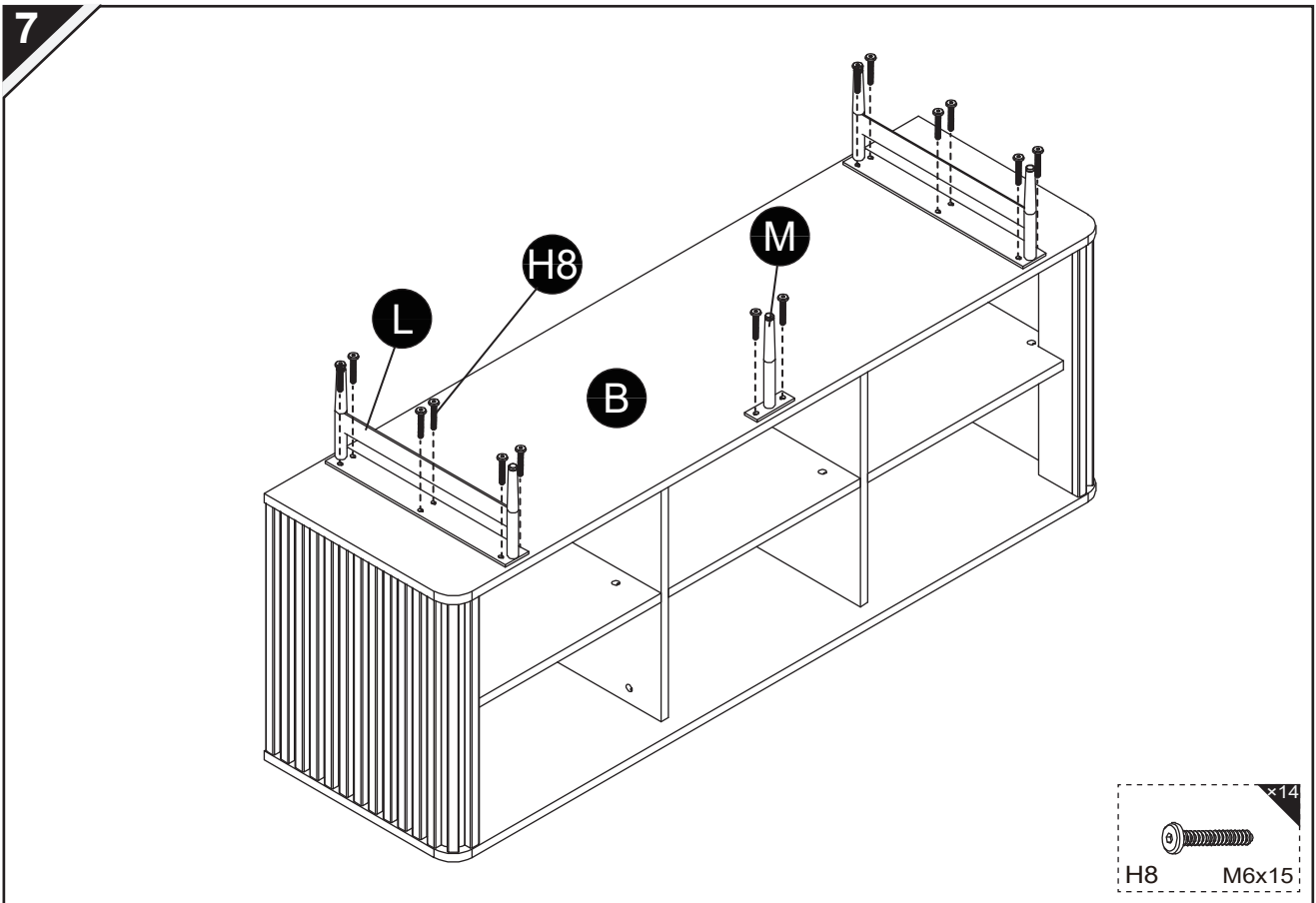

Contact person
tectake Ltd
18 Soho Square
London W1D 3QL
United Kingdom
Telephone: +44 203 488 4565
www.tectake.co.uk
mail@tectake.co.uk

Ansprechpartner
tectake GmbH
Tauberweg 41
97999 Igersheim
Telefon: +49 7931 991 920
www.tectake.de
E-Mail: verkauf@tectake.de

Personne de contact
Made4Home SAS
137 av. Gustave Eiffel
ZI Rognac Nord
13340 Rognac (France)
téléphone au: +33 4 42 81 81 80
www.tectake.fr
E-Mail: contact@tectake.fr

Persona de contacto
Ibérica de Distribuciones online del Hogar,
SLU,
Méndez Álvaro 20,
Madrid 28045,
Teléfono: +34 912907933
www.tectake.es
correo electrónico: mail@idoh.es

Persona di contatto
tenulodi S.r.l.
Via Manzano 70
33040 Premariacco (UD)
Numero di telefono: +39 0471 1800175
www.tectake.it
E-Mail: mail@tectake.it

Kontaktní osoba
TecTake s.r.o.
se sídlem na adrese Lidická 700 / 19, Veveří, 602 00 Brno, Česká republika
+420 538 880 441
www.tectake.cz
E-Mail: mail@tectake.cz

Kontaktná osoba
TecTake SLO d.o.o
Nazorjeva ulica 6, 1000 Ljubljana,
Telefónne číslo: +386 30 745 150
www.tectake.si
E-Mail: mail@tectake.si