

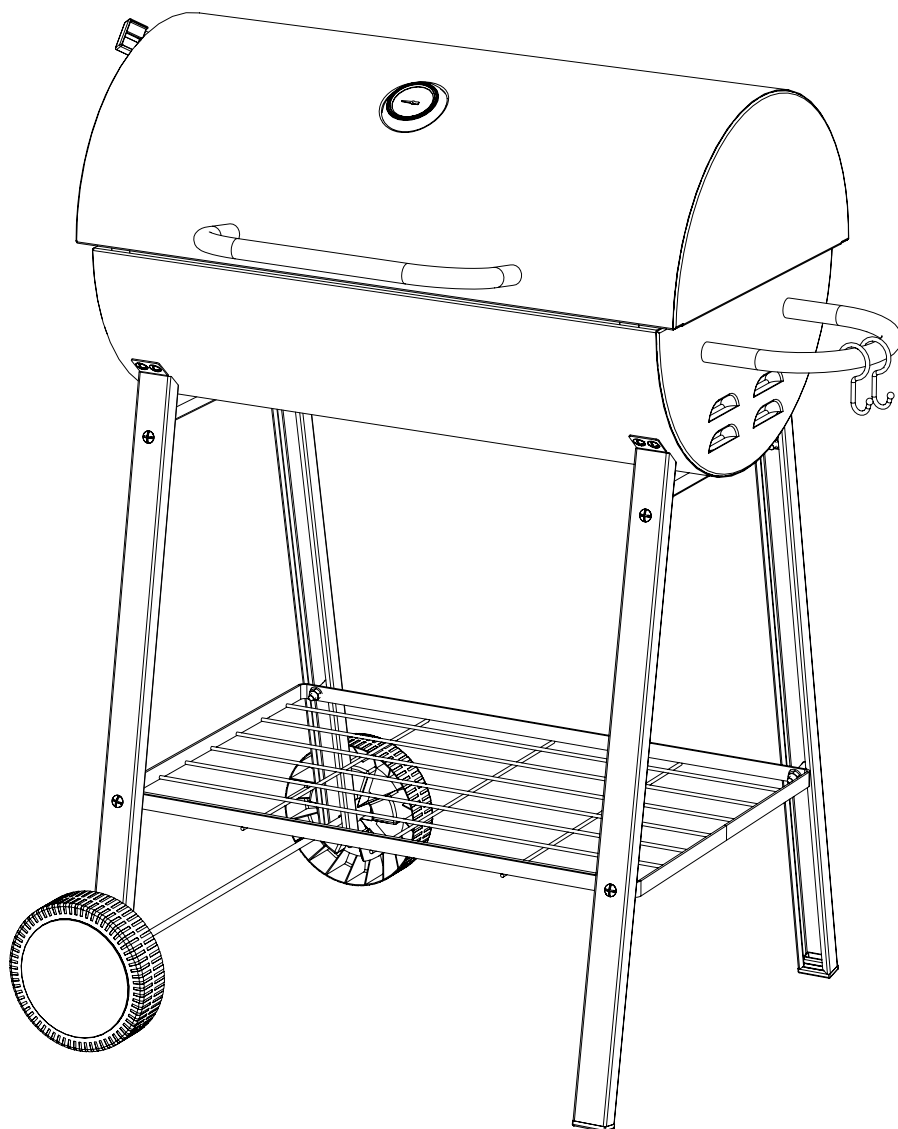

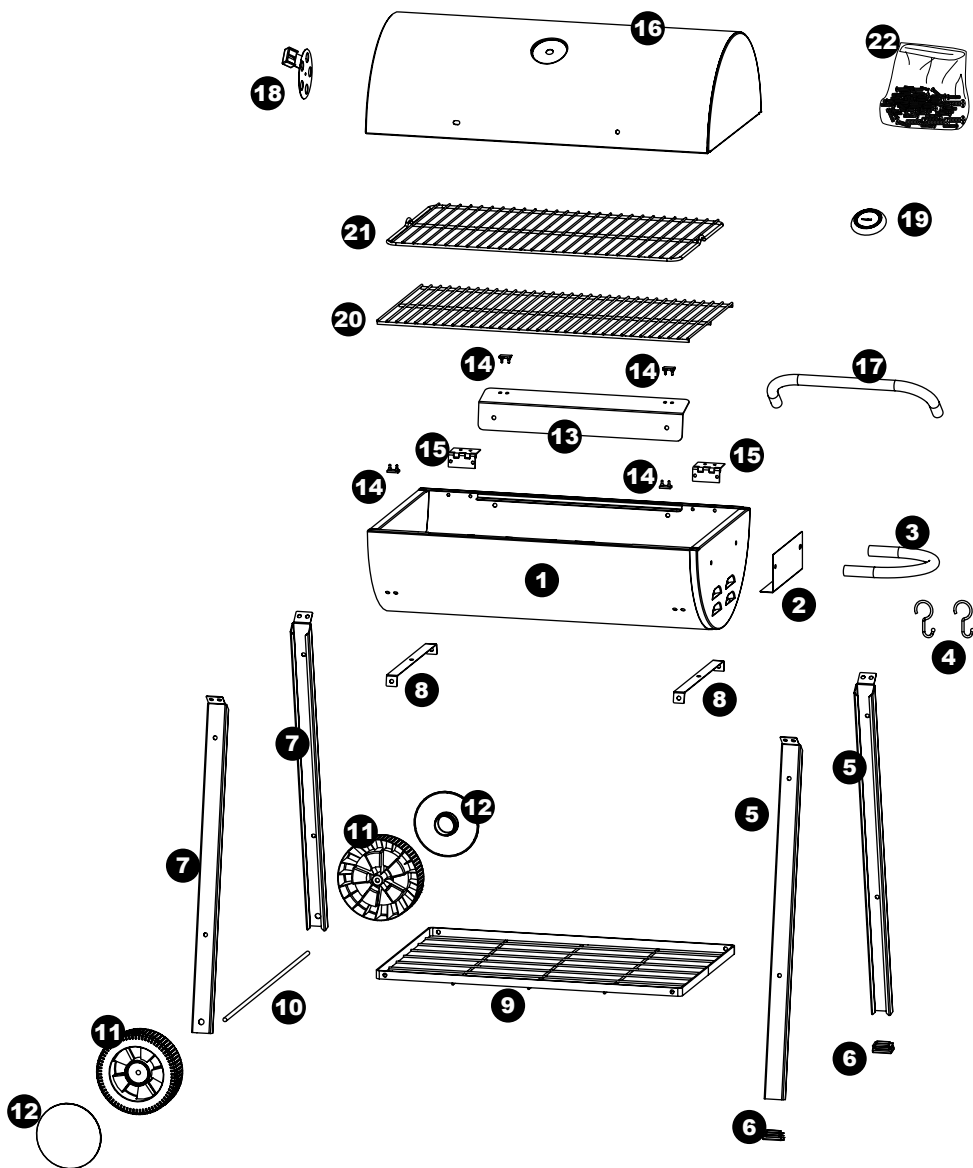









# TOM 376040i EN











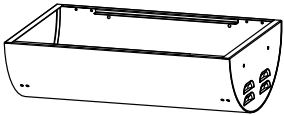



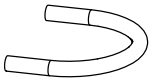



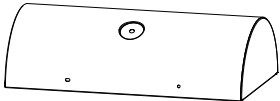

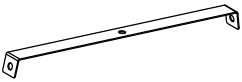

	6 x 35	4
	6 x 16	4
	6 x 12	16
	4 x 12	9

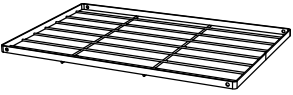
	Ø 8	1
	Ø 6	24
	Ø 4	9
	Ø 6	20
 brake nut	Ø 4	1
	Ø 4	8

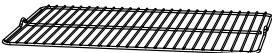
	Ø 8	1
	Ø 8	2

<b>1</b>		x 1	<b>12</b>		x 2
<b>2</b>		x 1	<b>13</b>		x 1
<b>3</b>		x 1	<b>14</b>		x 4
<b>4</b>		x 2	<b>15</b>		x 2
<b>5</b>		x 2	<b>16</b>		x 1
<b>6</b>		x 2	<b>17</b>		x 1
<b>7</b>		x 2	<b>18</b>		x 1
<b>8</b>		x 2	<b>19</b>		x 1
<b>9</b>		x 1	<b>20</b>		x 1
<b>10</b>		x 1	<b>21</b>		x 1
<b>11</b>		x 2	<b>22</b>		

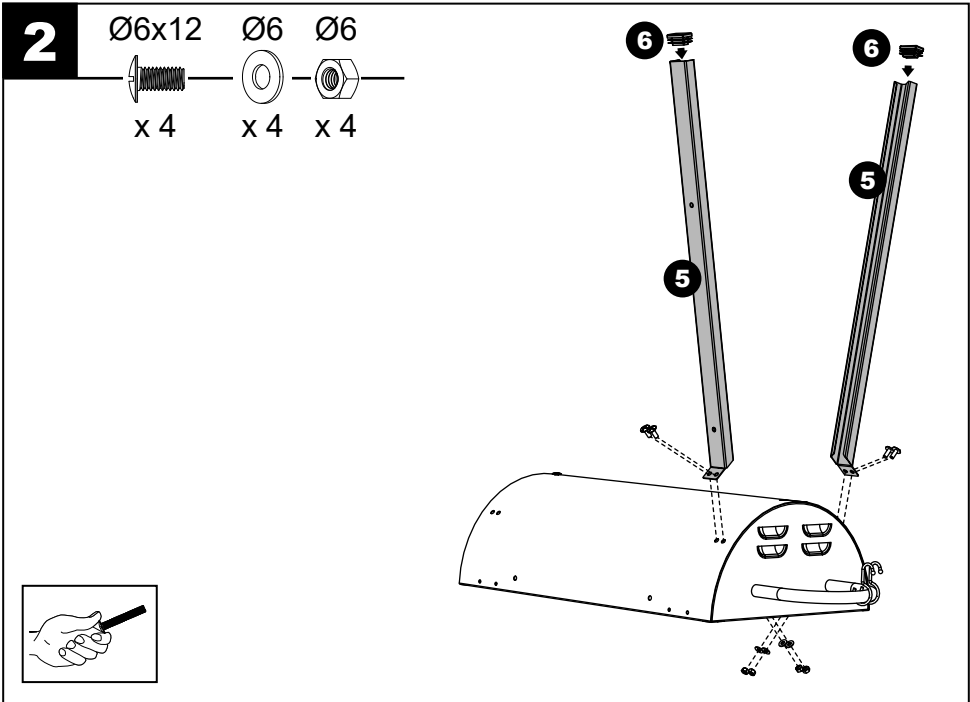
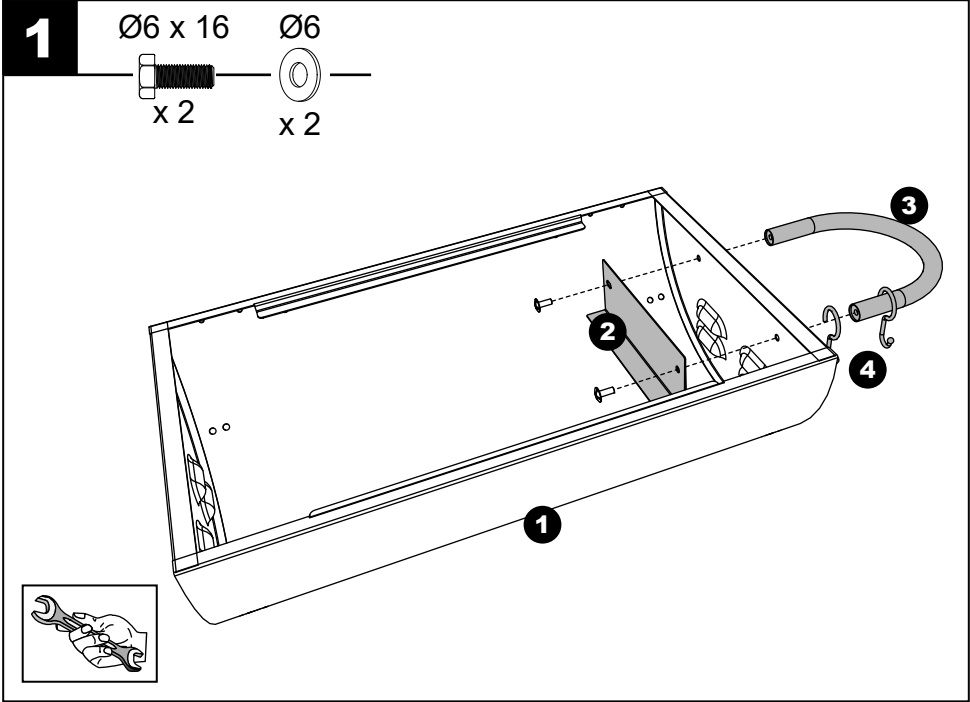

**3**

Ø6x12

Ø6

Ø6



x 4

x 4

x 4

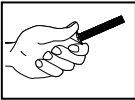
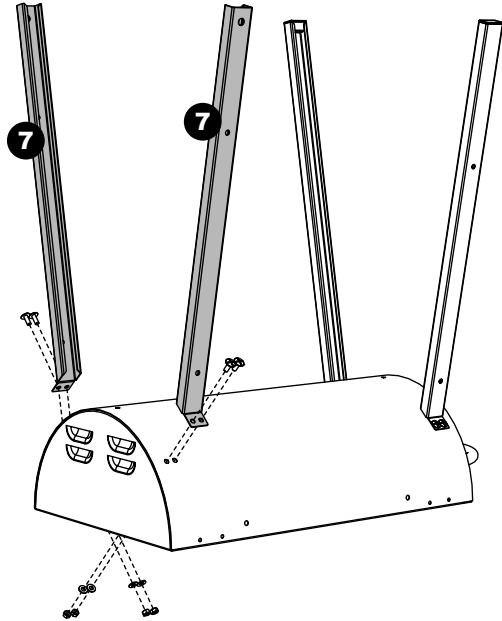
**4**

Ø6x12

Ø6x35

Ø6

Ø6



x 6

x 4

x 10 x 10

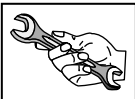
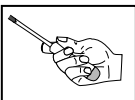
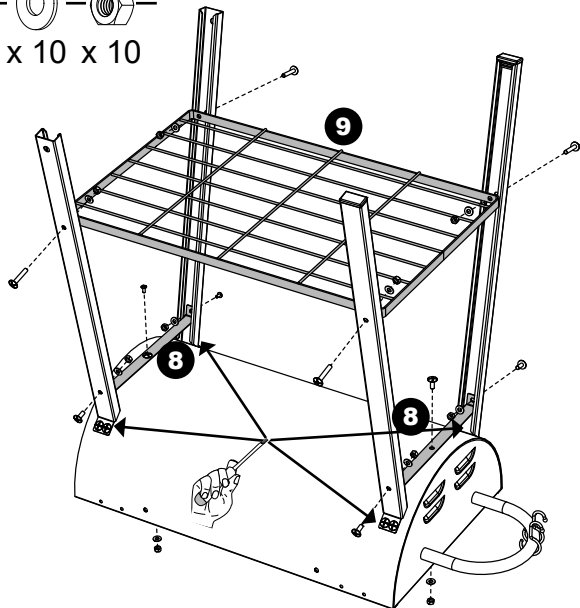

**5**

Ø8 Nylstop

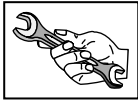
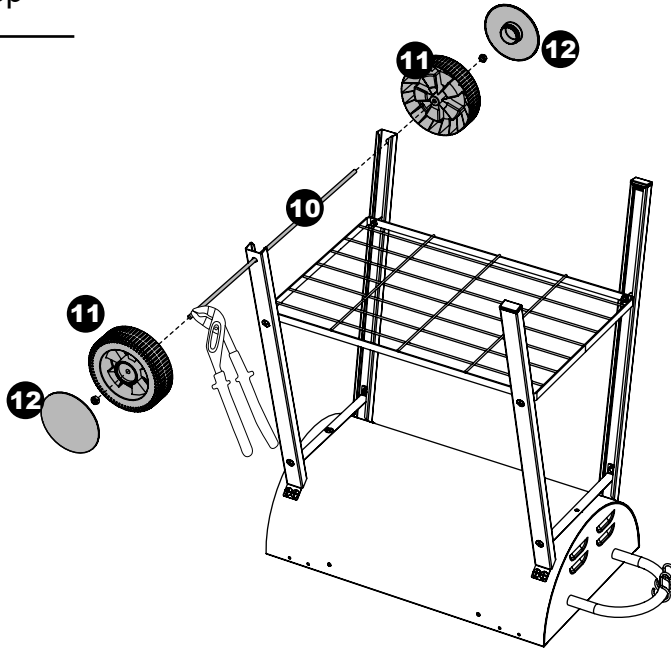

x 2

**6**

Ø6x12

Ø6

Ø6



x 2



x 2



x 2

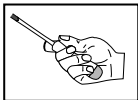
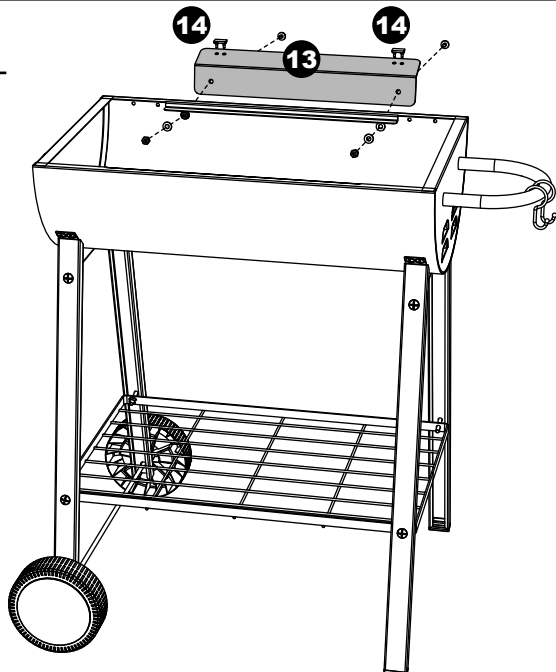

**7**

Ø4x12 Ø4 Ø4

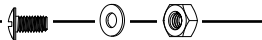
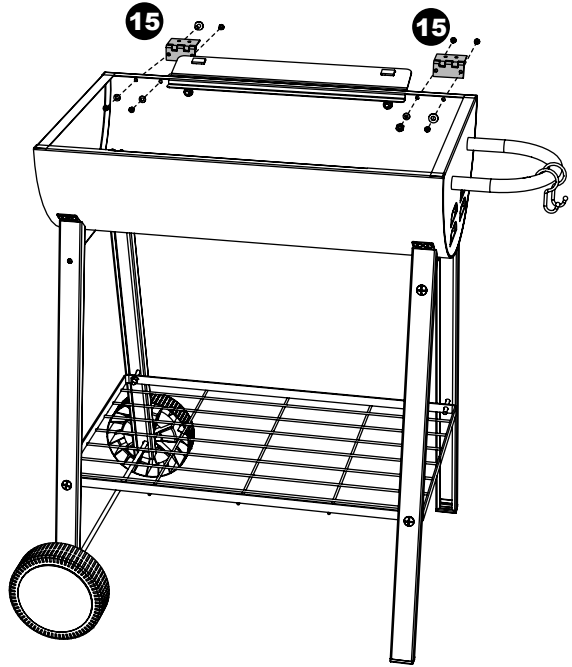
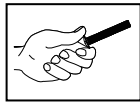
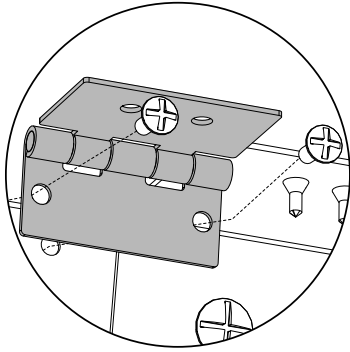
  
x 4 x 4 x 4
**8**

Ø4x12 Ø4 Ø4

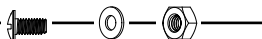
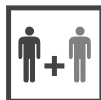
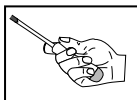
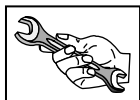
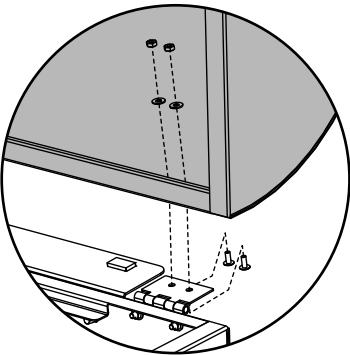
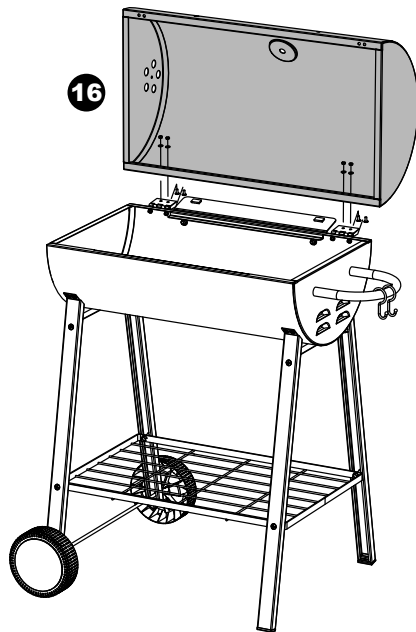
  
x 4 x 4 x 4
**16**

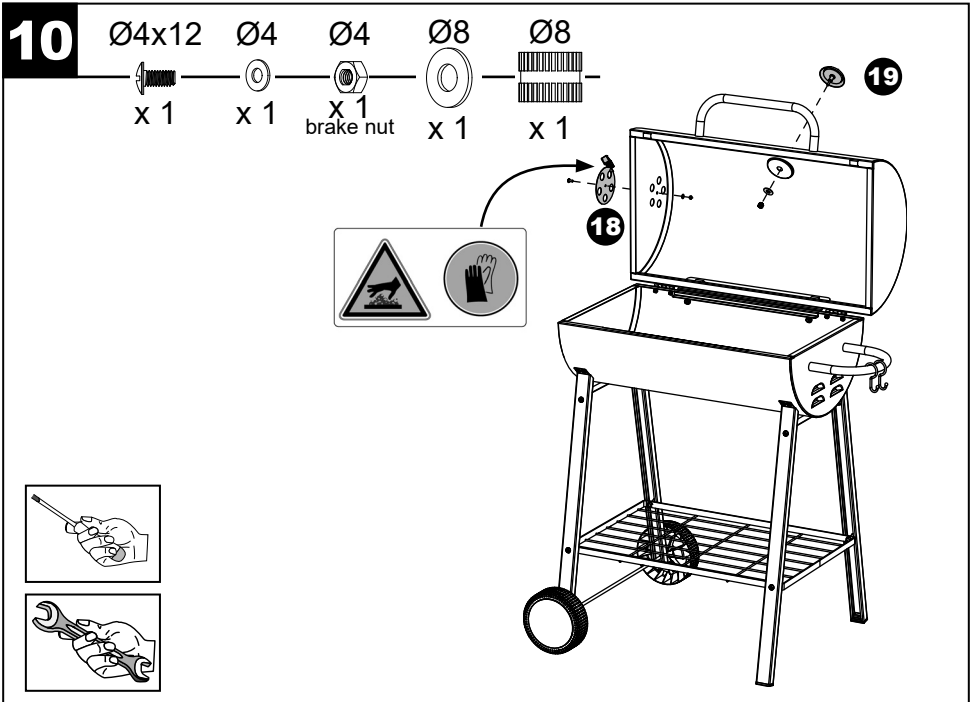
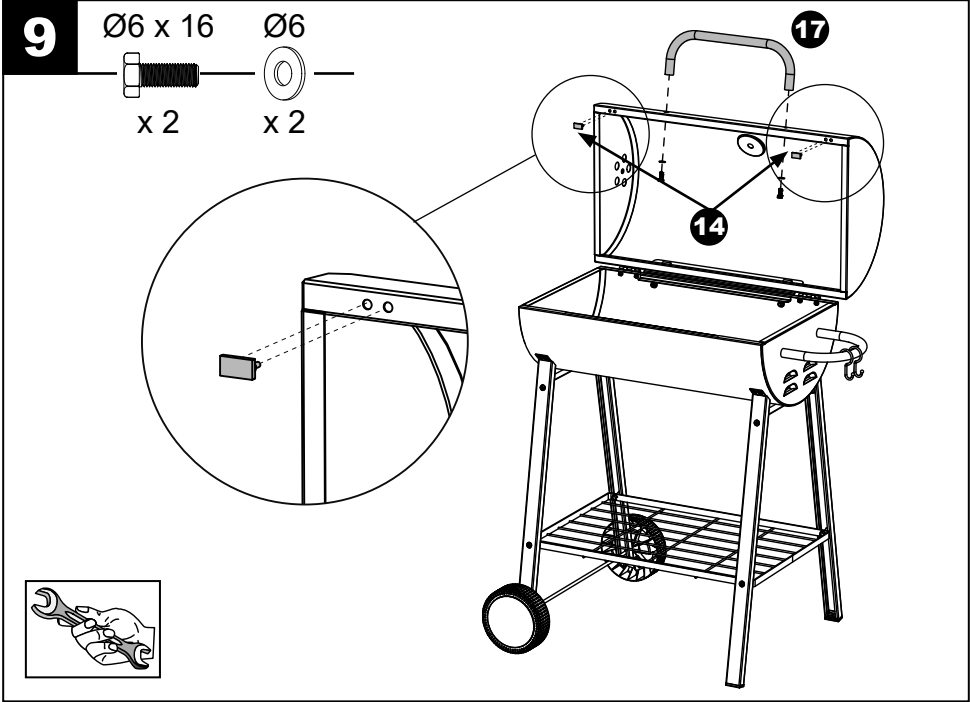



11

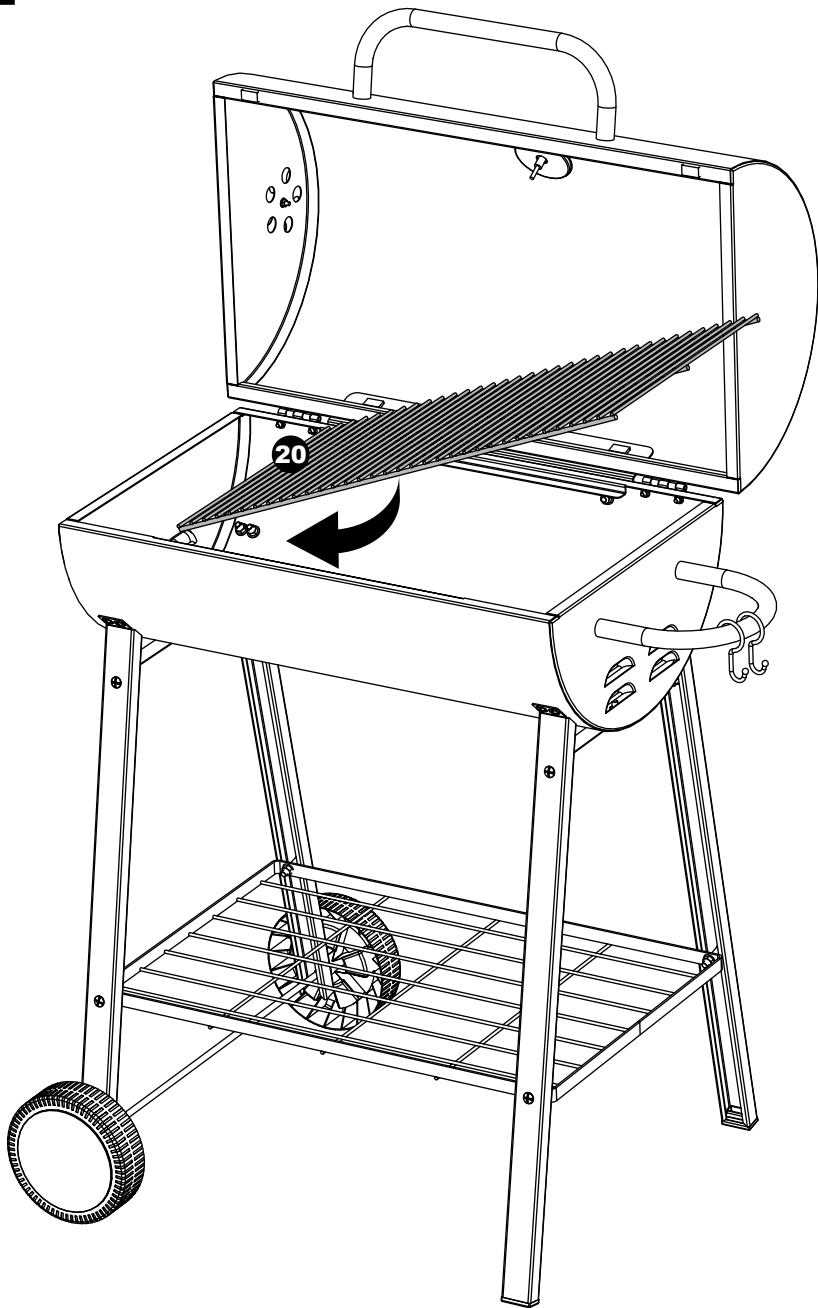

12

